



X1-Hybrid-LV

3.0 KW / 3.7 KW / 4.0 KW / 4.6 KW/
5.0 KW / 6.0 KW

User Manual

Version 3.0

www.solaxpower.com



©Manual in the QR code or
at <http://kb.solaxpower.com/>

STATEMENT

Copyright

Copyright © SolaX Power Technology (Zhejiang) Co., Ltd. All rights reserved.

No part of this manual may be reproduced, transmitted, transcribed, stored in a retrieval system, or translated into any language or computer language, in any form or by any means without the prior written permission of SolaX Power Technology (Zhejiang) Co., Ltd.

Trademarks



SOLA X and other symbol or design (brand name, logo) that distinguishes the products or services offered by SolaX has been trademark protected. Any unauthorized use of the above stated trademark may infringe the trademark right.

Notice

Please note that certain products, features, and services mentioned in this document may not be within the scope of your purchase or usage. Unless otherwise specified in the contract, the contents, information, and recommendations presented in this document are provided "as is" by SolaX. We do not provide any warranties, guarantees, or representations, whether express or implied.

The content of the documents is reviewed and updated as needed. However, occasional discrepancies may occur. SolaX retains the right to make improvements or changes in the product(s) and the program(s) described in this manual at any time without prior notice.

The images included in this document are solely for illustrative purposes and may differ based on the specific product models.

For more detailed information, kindly visit the website of SolaX Power Technology (Zhejiang) Co., Ltd. at www.solaxpower.com.

SolaX retains all rights for the final explanation.

About This Manual

Scope of Validity

This manual is an integral part of X1-Hybrid-LV series inverter. It describes the transportation, storage, installation, electrical connection, commissioning, maintenance and troubleshooting of the product. Please read it carefully before operating.

This manual is valid for the following inverter models:

- X1-Hybrid-3.0-LV
- X1-Hybrid-3.7-LV
- X1-Hybrid-4.0-LV
- X1-Hybrid-4.6-LV
- X1-Hybrid-5.0-LV
- X1-Hybrid-6.0-LV

Model description

X1-Hybrid-3.0-LV



Item	Meaning	Description
1	Product family name	"X1-Hybrid-LV" Series: a series of energy storage inverter which support photovoltaic grid-connected.
2	Power	"3.0": rated output power of 3.0 kW.
4	Voltage	"LV": low voltage.



Target Group

The installation, maintenance and grid-related setting can only be performed by qualified personnel who:

- Are licensed and/or satisfy state and local jurisdiction regulations.
- Have good knowledge of this manual and other related documents.

Conventions

The symbols that may be found in this manual are defined as follows.

Symbol	Description
 DANGER	Indicates a hazardous situation which, if not avoided, will result in death or serious injury.
 WARNING	Indicates a hazardous situation which, if not avoided, could result in death or serious injury.
 CAUTION!	Indicates a hazardous situation which, if not avoided, could result in minor or moderate injury.
NOTICE!	Provides tips for the optimal operation of the product.

Change History

Version 03 (2024-08-01)

Updated 8.7 Monitoring Connection (Modified WiFi+LAN mode)

Version 02 (2024-03-11)

Updated 8.4 PV Connection (Modified PV terminal)

Version 01 (2024-01-12)

Updated the whole manual to a new template.

Updated the content and diagram in 8.6.3 Parallel Connection.

Updated 2.7 Work Mode and 10 Operation on LCD.

Version 00 (2023-09-27)

Initial release

Table of Contents

1	Safety	1
1.1	General Safety	1
1.2	Safety Instructions of PV, Inverter and Grid	1
1.2.1	Safety Instructions of PV	2
1.2.2	Safety Instructions of Inverter	2
1.2.3	Safety Instructions of Utility Grid	3
2	Product Overview	4
2.1	Product Introduction	4
2.2	Supported Power Grid	4
2.3	Appearance	5
2.3.1	Dimensions	6
2.3.2	Control Panel	6
2.4	Symbols on the Label and Inverter	8
2.5	Working Principle	9
2.5.1	Circuit Diagram	9
2.5.2	Application Schemes	10
2.6	Working State	12
2.7	Working Mode	12
2.7.1	Self consumption mode	12
2.7.2	Backup Mode	13
2.7.3	Time of use mode	14
2.7.4	SUB Mode	14
2.7.5	SBU Mode	15
2.7.6	MKS Mode	16
3	System Overview	17
4	Transportation and Storage	19
5	Preparation before Installation	20
5.1	Selection of Installation Location	20
5.1.1	Environment Requirement	20
5.1.2	Installation Carrier Requirement	21
5.1.3	Clearance Requirement	22
5.2	Tools Requirement	23
5.3	Additionally Required Materials	24

- 6 Unpacking and Inspection 25**
 - 6.1 Unpacking.....25
 - 6.2 Scope of Delivery.....26
- 7 Mechanical Installation 28**
 - 7.1 Dimensions for mounting.....29
 - 7.2 Installation procedures.....30
- 8 Electrical Connection 33**
 - 8.1 Terminals of Inverter33
 - 8.2 PE Connection35
 - 8.3 AC Connection.....38
 - 8.4 PV Connection46
 - 8.5 Battery Power Cable Connection.....51
 - 8.5.1 Battery connection.....51
 - 8.5.2 Battery temperature sensor connection.....56
 - 8.6 Communication Connection.....58
 - 8.6.1 CT/meter port connection58
 - 8.6.2 BMS/DRM/COM port connection.....64
 - 8.6.3 Parallel Connection.....68
 - 8.6.4 Dry-contact output connection.....71
 - 8.7 Monitoring Connection73
- 9 System Commissioning 77**
 - 9.1 Checking before Power-on.....77
 - 9.2 Powering on the System.....77
 - 9.3 Checking after Power-on78
- 10 Operation on LCD..... 79**
 - 10.1 Introduction of Control Panel.....79
 - 10.2 Screen Menu Structure81
 - 10.3 LCD Operation Settings82
 - 10.3.1 Root menu82
 - 10.3.2 Main menu82
- 11 Operation on SolaX App and Web..... 90**
 - 11.1 Introduction of SolaXCloud.....90
 - 11.2 Operation Guide on SolaXCloud App90
 - 11.2.1 Downloading and installing App.....90
 - 11.3 Operation Guide on SolaXCloud Web91
- 12 Troubleshooting and Maintenance 92**

- 12.1 Troubleshooting.....92
- 12.2 Maintenance.....99
- 12.3 Firmware Upgrade.....100
 - 12.3.1 Upgrade preparation.....100
 - 12.3.2 Upgrade steps100
- 13 Decommissioning.....102**
 - 13.1 Power off.....102
 - 13.2 Disassembling the Inverter103
 - 13.3 Packing the Inverter104
 - 13.4 Disposing of the Inverter104
- 14 Technical Data105**
 - 14.1 DC Input105
 - 14.2 AC Input&Output.....105
 - 14.3 EPS Output105
 - 14.4 Battery Data.....106
 - 14.5 System Data.....106
 - 14.6 Protection Device.....106
 - 14.7 Power Consumption & Environment Limit.....107
 - 14.8 Protection Device.....107

1 Safety

1.1 General Safety

The series inverter has been meticulously designed and thoroughly tested to comply with all relevant state and international safety standards. Nevertheless, like all electrical and electronic equipment, safety precautions must be observed and followed during the installation of the inverter to minimize the risk of personal injury and ensure a safe installation.

Please thoroughly read, comprehend, and strictly adhere to the comprehensive instructions provided in the user manual and any other relevant regulations prior to the installation of the inverter. The safety instructions in this document serve as supplementary guidelines to local laws and regulations.

SolaX shall not be liable for any consequences resulting from the violation of the storage, transportation, installation, and operation regulations outlined in this document. Such consequences include, but are not limited to:

- Inverter damage caused by force majeure events, such as earthquakes, floods, thunderstorms, lightning, fire hazards, volcanic eruptions, and similar events.
- Inverter damage due to human causes.
- Usage or operation of the inverter in violation of local policies or regulations.
- Failure to comply with the operation instructions and safety precautions provided with the product and in this document.
- Improper installation or usage of the inverter in unsuitable environmental or electrical conditions.
- Unauthorized modifications to the product or software.
- Inverter damage occurring during transportation by the customer.
- Storage conditions that do not meet the requirements specified in this document.
- Installation and commissioning performed by unauthorized personnel who lack the necessary licenses or do not comply with state and local jurisdiction regulations.

1.2 Safety Instructions of PV, Inverter and Grid

Save these important safety instructions. Failure to do so may result in damage to the inverter and injury or even loss of life.

1.2.1 Safety Instructions of PV

 **DANGER!**

Potential risk of lethal electrical shock associated with the photovoltaic (PV) system

- Exposure to sunlight can result in the generation of high DC voltage by PV modules, which can lead to electric shock causing severe injuries or even death.
- Never touch the positive or negative poles of the PV connecting device, and avoid touching both poles simultaneously.
- Do not ground the positive or negative poles of the PV modules.
- Only qualified personnel can perform the wiring of the PV modules.

 **WARNING!**

- Overvoltage protection with surge arresters should be provided when the PV system is installed. The grid connected inverter is fitted with SPDs on both PV input side and MAINS side.
- Please consult professionals before installing SPDs.

 **WARNING!**

- Make sure that the input DC voltage does not exceed the maximum DC input voltage specified for the inverter. Overvoltage can cause irreversible damage to the inverter, and such damage is not covered by the warranty.

1.2.2 Safety Instructions of Inverter

 **DANGER!**

Potential risk of lethal electrical shock associated with the inverter

- Only operate the inverter if it is in a technically faultless condition. Operating a faulty inverter may lead to electric shock or fire.
- Do not attempt to open the enclosure without authorization from SolaX. Unauthorized opening of the enclosure will void the warranty and can result in lethal danger or serious injury due to electric shock.
- Make sure that the inverter is reliably grounded before any operation to prevent the risk of electric shock causing lethal danger or serious injury.
- Only qualified personnel can perform the installation, wiring, maintenance of the inverter by following this document and the related regulations.

WARNING!

- During operation, avoid touching any parts of the inverter other than the DC switch and LCD panel (if any).
- Never connect or disconnect the AC and DC connector while the inverter is running.
- Prior to conducting any maintenance, turn off the AC and DC power and disconnect them from the inverter. Wait for 5 minutes to fully discharge the energy.

WARNING!**Potential danger of scalding due to the hot enclosure of the inverter**

- Avoid touching the inverter while it is running, as it becomes hot during operation and may cause personal injuries.

WARNING!

- When handling the battery, carefully follow all safety instructions provided in the battery manual. The battery used with the inverter must meet the specified requirements of the series inverter.

CAUTION!

- Make sure that children are supervised to prevent them from playing with the inverter.
- Pay attention to the weight of the inverter and handle it properly to avoid personal injuries.
- Use insulated tools when installing the device, and always wear personal protective equipment during installation and maintenance.

NOTICE!

- If an external Residual Current Device (RCD) is required by local regulations, verify the type of RCD required. It is recommended to use a Type-A RCD with a rating of 300 mA unless a lower value is required by the specific local electric codes. When required by local regulations, the use of an RCD type B is permitted.
- Keep all product labels and the nameplate on the inverter clearly visible and well-maintained.

1.2.3 Safety Instructions of Utility Grid

NOTICE!

- Only connect the inverter to the grid with the permission of the local utility grid company.

2 Product Overview

2.1 Product Introduction

The X1-Hybrid-LV series inverter is a high-quality inverter that combines solar inverter, solar charger, AC charger, and emergency power supply (EPS) function with an IP65 degree of protection. The inverter can be used to optimize self-consumption, store energy in batteries for future use, or feed it into the public grid. The way it operates depends on user preferences.

2.2 Supported Power Grid

There are different ways of wiring for different grid systems. Three grid types, TT / TN-S / TN-C-S are shown as below:

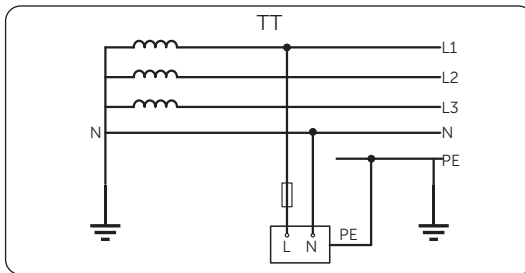

Figure 2-1 Supported power grid TT

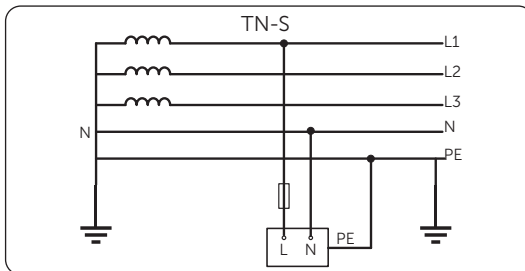

Figure 2-2 Supported power grid TN-S

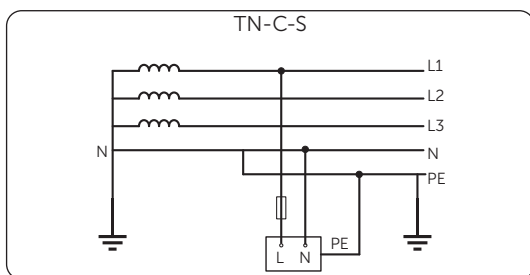

Figure 2-3 Supported power grid TN-C-S

2.3 Appearance

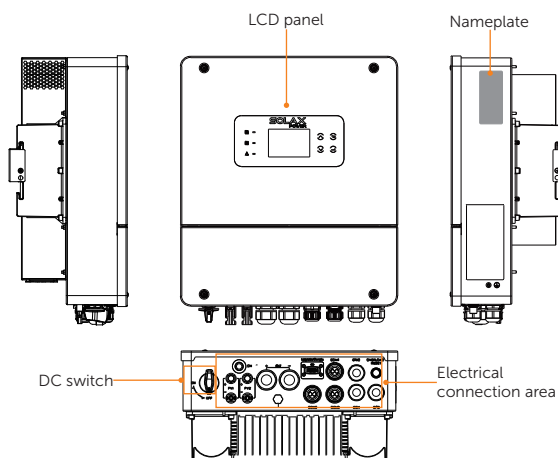

Figure 2-4 Appearance

Table 2-1 Description of appearance

Item	Description
Nameplate	Nameplate clearly identifies the device type, serial number, specific DC / AC parameters, certification, etc.
LCD panel	Including screen, indicators and keys. Screen displays the information; indicators indicate the status of inverter. Keys are used to perform the parameter setting.
DC switch	Disconnect the DC circuit when necessary.
Electrical connection area	Including PV terminals, battery terminals, AC terminals, communication terminals, etc.

2.3.1 Dimensions

- Dimension of Inverter

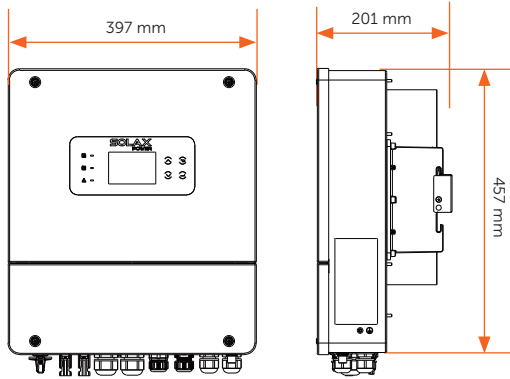

Figure 2-5 Dimension of Inverter

2.3.2 Control Panel

- Control Panel of Inverter

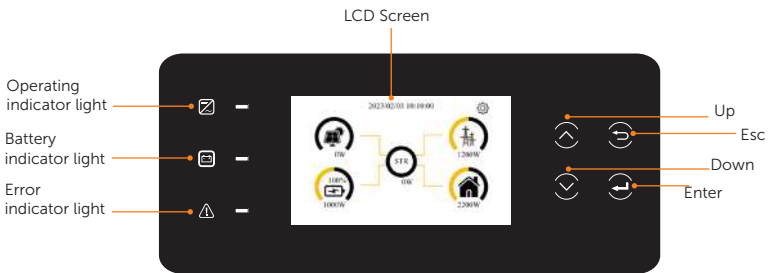













Figure 2-6 Control Panel of Inverter

* Please refer to the actual product for the color of the LCD screen.

Table 2-2 Definition of keys

Key	Definition
ESC key	Exit from the current interface or function
Up key	Move the cursor to the upper part or increase the value
Down key	Move the cursor to the lower part or decrease the value
Enter key	Confirm the selection

Table 2-3 Definition of indicators of Inverter











LED indicator	Status	Definition
 Operating	 Solid green	The inverter is in grid-connected operation state or off-grid operation state.
	 Green blinking	The inverter is in the process of grid connection or off-grid.
	 Light off	The inverter is in a fault or manual shutdown state.
 Battery	 Solid blue	The battery is online and the voltage is normal.
	 Light off	Low battery voltage or no battery.
 Error	 Solid red	The inverter is in fault status.
	 Red blinking	The inverter has alarm information.
	 Light off	There are no faults and alarms in the inverter.

NOTICE!

- While upgrading, the green, blue and red indicator lights will flash in turns, indicating that the upgrade is in progress.

2.4 Symbols on the Label and Inverter

Table 2-4 Description of symbols

Symbol	Description
	CE mark. The inverter complies with the requirements of the applicable CE guidelines.
	TUV certified.
	RCM mark. The inverter complies with the requirements of the applicable RCM guidelines.
	Additional grounding point
	Beware of hot surface. Do not touch a running inverter, as the inverter becomes hot during operation!
	Risk of electric shock. High voltage exists after the inverter is powered on!
	Risk of danger Potential hazards exist after the inverter is powered on!
	Observe enclosed document.
	The inverter can not be disposed together with the household waste.
	Do not operate this inverter until it is isolated from battery, mains and on-site PV generation source.
	Danger to life due to high voltage. Residual voltage exists after the inverter is powered off, which needs 5 minutes to fully discharge. Wait 5 minutes before attempting any service.

2.5 Working Principle

2.5.1 Circuit Diagram

The inverter is equipped with multi-channel MPPT for DC input to ensure maximum power even under different photovoltaic input conditions. The inverter unit converts direct current into alternating current that meets the requirements of the power grid and feeds it into the power grid. The lightning arrester at AC / DC side realizes the function of surge protection. The principle design of inverter is shown in the figure below:

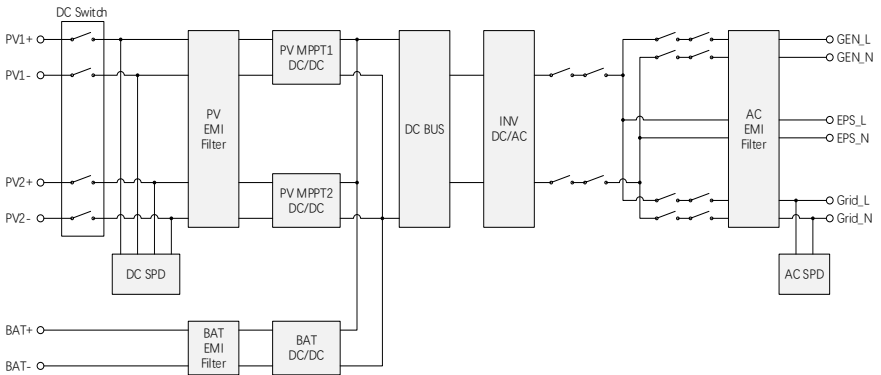

Figure 2-7 Circuit Diagram for X1-Hybrid-LV series inverter

2.5.2 Application Schemes

The series inverter is a high-quality inverter that combines solar inverter, solar charger, AC charger, and emergency power supply (EPS) function with an IP65 degree of protection. The inverter can be used to optimize self-consumption, store energy in batteries for future use, or feed it into the public grid. The way it operates depends on user preferences.

Diagram A: Neutral line and PE line are separated from each other, and the emergency load is connected to the EPS port; (For most countries)

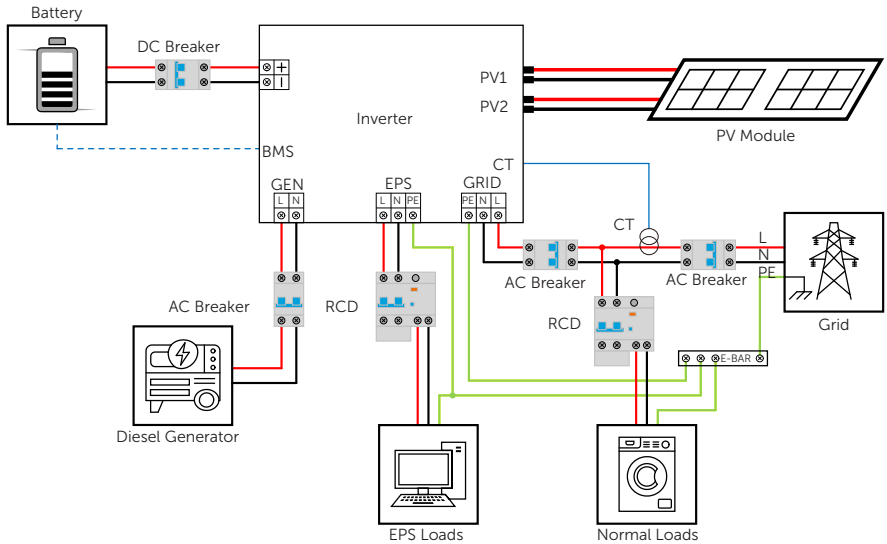

Figure 2-8 Wiring methods for most of the countries

Diagram B: Neutral line and PE line are combined together, and the emergency load is connected to the EPS port. (For Australia)

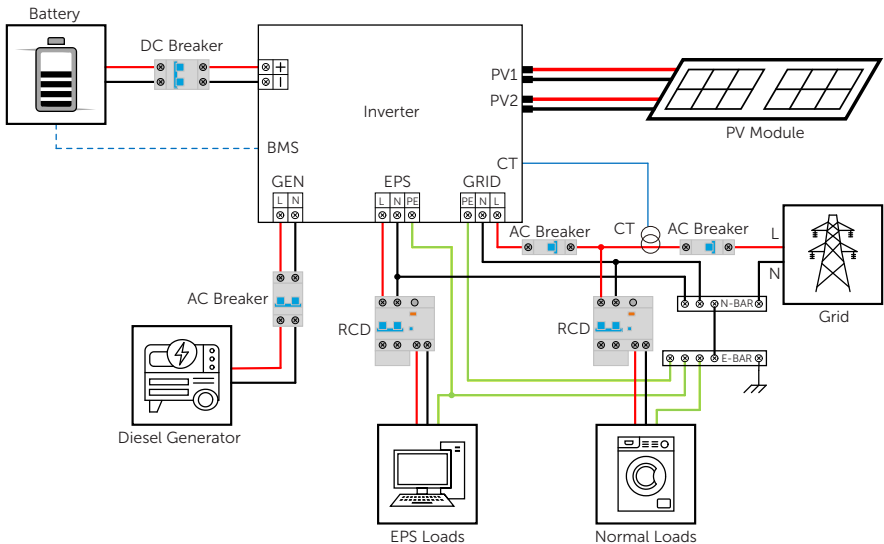

Figure 2-9 Wiring methods for Australia

NOTICE!

- When a power cut occurs suddenly, the inverter connects the N line of the EPS load to the ground through a relay, establishing a fixed zero potential for the EPS load and ensuring the safe use of electricity by users.
- Ensure that the rated power of the EPS load falls within the EPS rated output power range; otherwise, the inverter will issue an overload warning.
- Please verify with the grid operator if there are any special regulations for grid connection.

2.6 Working State

The series inverter has Start, On and Off state.

Table 2-5 Description of working state

State	Description
Start	The inverter is checking for conditions to enter On state.
On	The inverter is working normally.
Off	<ul style="list-style-type: none"> The inverter is waiting for the conditions to be met in order to enter the Start state. The inverter detects error occurred and prompts error code.

2.7 Working Mode

There are different work modes of the inverter based on different needs.

Applicable areas	Work modes
Countries other than Pakistan (including India, Vietnam, South Africa, Uzbekistan)	Self consumption mode, backup mode and time of use mode
Pakistan	SUB mode, SBU mode, MKS mode and Time of use mode

For how to set the working mode, please refer to ["10.3 LCD Operation Settings"](#).

2.7.1 Self consumption mode

This mode is applicable to countries other than Pakistan.

Application Scenarios:

This mode is suitable for applications where electricity prices are high and solar power generation is not allowed to feed into the grid. Solar power takes priority in supplying the load, with any excess power being stored in the battery for later use.

The load is primarily powered by solar energy, with the battery taking over if solar power is insufficient, and grid power being the final option.

If the PV power exceeds the load power, the excess power will be used to charge the battery.

This mode defaults to zero feed-in control, preventing any power from being fed back into the grid.

Note:

In this mode, when the battery voltage is lower than the settable battery voltage of load-to-grid power supply, the battery will start charging, and the load will be powered by grid, and the battery will be charged in the following modes according to the priority setting of battery charging power supply:

Only Solar charging: Solar charges the battery, and the load is completely powered by the power grid;

Solar then Utility charging: If there is Solar energy, only Solar energy will charge the battery; if there is no solar energy, the power grid will charge the battery;

Solar+Utility: Same as 2 (Only Utility charging);

When the battery is charged to the battery voltage supplied by the load to the battery, it will return to the normal operation mode.

2.7.2 Backup Mode

This mode is applicable to countries other than Pakistan.

Application Scenarios:

This mode uses the energy storage system as a backup power source and is suitable for applications where power outages are frequent. When the grid is normal, the load is powered by solar and the grid, and the battery is only charged without discharging. When there is a power outage, the energy storage system works in off-grid mode to supply power to important loads.

The load is prioritized to be powered by solar. If the solar power is insufficient, the load is powered by the grid. If the grid is unavailable, the load is powered by the battery + solar in off-grid mode.

If the PV power is greater than the load power, the excess power charges the battery.

After the battery is fully charged, the excess PV power can be either fed back to the grid or limited based on the zero-export setting.

(In terms of program control, it is consistent with the Self Consumption mode, where the battery charging/discharging power is controlled to be zero or the allowed power for grid feeding. However, the battery only charges and does not discharge.)

Note:

In this mode, if the priority setting for the battery charging source is:

Only Solar charging: No response, and the normal operating mode mentioned above is followed.

Solar then Utility charging: If solar power is available, only solar charges the battery. In the absence of solar power, the grid charges the battery.

Solar + Utility: Same as mode 2 (Only Utility charging).

2.7.3 Time of use mode

This mode is applicable to all countries including Pakistan.

Application Scenarios:

This mode is more suitable for applications with peak and off-peak electricity price differences. When the electricity price is high, the battery discharges to power the load. When the electricity price is low, the battery is charged from solar or the grid to reach full capacity.

It provides three battery discharge time slots, corresponding to peak periods with higher electricity prices. During these periods, the battery discharges to power the load, providing economic value to the customer. The operation during these periods is consistent with the normal operation mode of the Self Consumption mode. The difference lies in the fact that when the battery voltage drops below the voltage at which the load is switched to grid power in the Time of Use mode, the battery only charges without discharging.

Note:

In this mode, it also provides three battery charging time slots, corresponding to off-peak periods with lower electricity prices. During these periods, the battery is charged from PV or the grid, and the load is powered by the grid, providing economic value to the customer. Different priority settings for the battery charging source can be selected for each of the three battery charging time slots, and it is possible for the battery to reach full capacity and enter the float charging stage during these time slots.

Outside the peak and off-peak time slots set, the battery follows the priority setting mode for the battery charging source.

2.7.4 SUB Mode

This mode is applicable under Pakistan's safety, corresponding to backup mode for other countries.

Application Scenarios:

This mode uses the energy storage system as a backup power source and is suitable for applications with frequent power outages. When the grid is operational, the load is powered by solar and the grid, and the battery only charges without discharging. With the grid available, the battery is generally kept at full charge. It only operates in off-grid mode to supply power to critical loads when the grid power is cut off.

The load is primarily powered by solar, and if solar power is insufficient, the grid supplies power. In the absence of grid power, the system switches to off-grid mode, using the battery and solar to power the load.

If the power generated by solar exceeds the load demand, the excess electricity is used to charge the battery.

After the battery is fully charged, whether the surplus PV power is fed back into the grid or limited depends on the setting for zero-export at the grid interface.

Note:

In this mode, if the priority setting for the battery charging source is as follows:

Only Solar Charging: No response, and the normal operation mode described above is followed.

Solar then Utility Charging: If solar power is available, the battery is exclusively charged by solar. In the absence of solar power, the grid charges the battery based on the maximum allowable grid charging current set at the grid interface.

Solar + Utility Charging: The battery is charged using the power from solar plus the maximum allowable grid charging current set at the grid interface.

2.7.5 SBU Mode

This mode is applicable under Pakistan's safety, corresponding to self consumption mode for other countries.

Application Scenarios:

This mode is suitable for applications where electricity prices are high and solar power cannot be fed into the grid. Solar power is prioritized for loads, and excess power is stored in the battery for later use. This mode is ideal for customers with low daytime electricity consumption and higher nighttime electricity consumption.

Loads are primarily powered by solar energy. If the solar power is insufficient, the battery will provide power. If the battery voltage drops below the voltage threshold for switching to grid supply in SBU mode, the loads will be powered by the grid. Once the battery voltage reaches the voltage threshold for switching back to solar and battery supply, the loads will be powered by solar power and the battery again.

If the solar power generated exceeds the load demand, the excess power will be used to charge the battery.

In this mode, zero export is enabled by default, meaning power cannot be fed back to the grid.

Note:

In this mode, if the battery voltage drops below the adjustable voltage threshold for switching to grid supply, the battery starts charging and the loads are powered by the grid. The battery charging mode depends on the priority settings:

Only solar charging: The battery is charged with solar power, and the loads are fully powered by the grid.

Solar then utility charging: If solar power is available, the battery is charged only with solar power. If there is no solar power, the battery is charged within the maximum current limit set for grid charging.

Solar + utility charging: The power generated by solar plus the maximum current limit set for grid charging on the interface will charge the battery simultaneously.

2.7.6 MKS Mode

This mode is applicable under Pakistan's safety.

Application Scenarios:

This mode is suitable for customers who have higher electricity consumption during certain periods of the day and lower consumption at night. When solar power is available, this mode is basically the same as the SBU mode, and the discharge range of the battery is wider than that of the SBU mode. The difference lies in the fact that the battery only starts charging and the load switches to grid power when the battery voltage falls below the minimum discharge voltage. Normal operation is resumed only when the battery is charged to a voltage higher than the maximum charging voltage.

At night when solar power is unavailable, this mode is basically the same as the SUB mode, with the battery only charging and not discharging, which prevents the battery from being depleted.

3 System Overview

System Overview

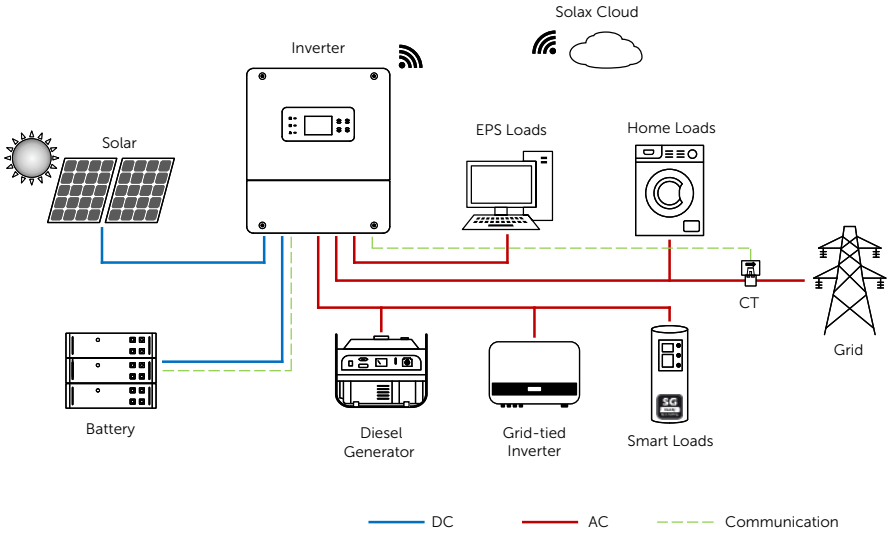

Figure 3-1 System overview diagram

Table 3-1 System item description

Item	Description
X1-Hybrid-LV series (the device covered in this manual)	The series inverter combines solar inverter, solar charger, AC charger and emergency power supply (EPS) function together with IP65 degree of protection. The inverter can be used to optimize self-comsumption, stored-in batteries for future use or fed into the public grid. The way it works depends on user preferences.!
PV String	For 3 kW to 6 kW inverter, the number of PV string is two.
Battery	The series inverter should pair with low voltage battery.
CT	CT is a device that monitors the input and output current of the grid.
Grid	220V/230V/240V grid are supported.
Grid-tied Inverter	A grid-connected inverter is a device that converts direct current into alternating current, used to integrate the electricity generated by solar panels or other renewable energy systems into the power grid.
Diesel Generaton	The generator is a machine for producing electricity.
SolaX Cloud	SolaX Cloud is an intelligent, multifunctional monitoring platform that can be accessed either remotely or through a hard wired connection. With the SolaX Cloud, the operators and installers can always view key and up-to-date data.

4 Transportation and Storage

If the inverter is not put into use immediately, the transportation and storage requirements needs to be met:

Transportation

- Observe the caution signs on the packaging of inverter before transportation.
- Pay attention to the weight of inverter. Be cautious to avoid injury when carrying X1-Hybrid-LV (gross weight: 20 kg). Four installers or lifting equipment are recommended.
- Wear protective gloves when carrying the equipment by hand to prevent injuries.
- When lifting up the inverter, hold the handle position and the bottom position of the inverter. Keep the inverter horizontal in case of falling down.

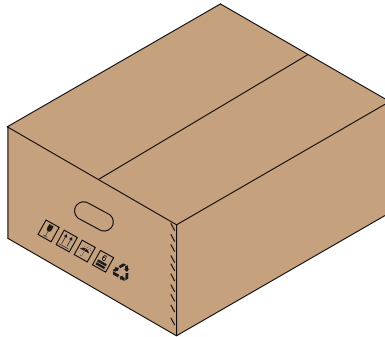

Figure 4-1 Caution signs on the packaging

Storage

- The inverter must be stored indoors.
- Do not remove the original packaging material and check the outer packaging material regularly.
- The storage temperature should be between -25°C and $+70^{\circ}\text{C}$. The humidity should be between 0% and 100%.
- Stack the inverter in accordance with the caution signs on the inverter carton to prevent their falling down and device damage. Do not place it upside down.

5 Preparation before Installation

5.1 Selection of Installation Location

The installation location selected for the inverter is quite critical in the aspect of the guarantee of machine safety, service life and performance. It has the IP65 ingress protection, which allows it to be installed outdoor. The installation position shall be convenient for wiring connection, operation and maintenance.

5.1.1 Environment Requirement

Make sure the installation site meets the following conditions:

- The ambient temperature: -25°C to $+60^{\circ}\text{C}$.
- The relative humidity shall be between 0-100%RH.
- Do not install the inverter in the areas where the altitude exceeds 3000 m.
- Install the inverter in a well-ventilated environment for heat dissipation. You are recommended to install an awning over the inverter if it is installed on a support outdoor.
- Do not install the inverter in areas with flammable, explosive and corrosive materials or near antenna.
- Avoid direct sunlight, rain exposure and snow laying up.

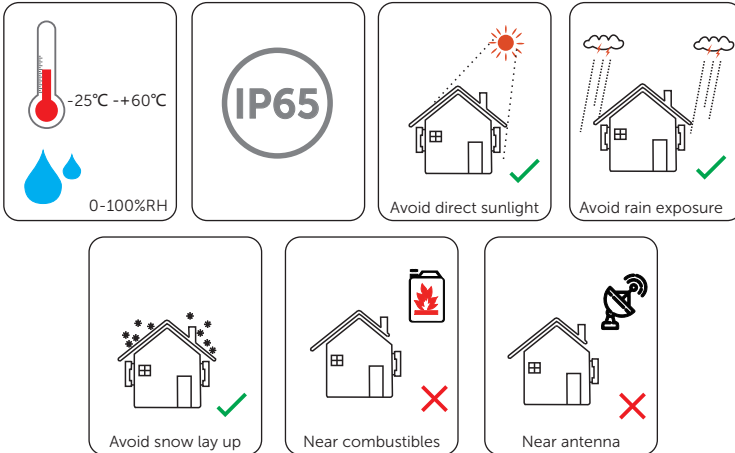

NOTICE!

- For outdoor installation, precautions against direct sunlight, rain exposure and snow accumulation are recommended.
- Exposure to direct sunlight raises the temperature inside the device. This temperature rise poses no safety risks, but may impact the device performance.
- Install the inverter at least 500 meters away from the coast and avoid sea breeze directly.

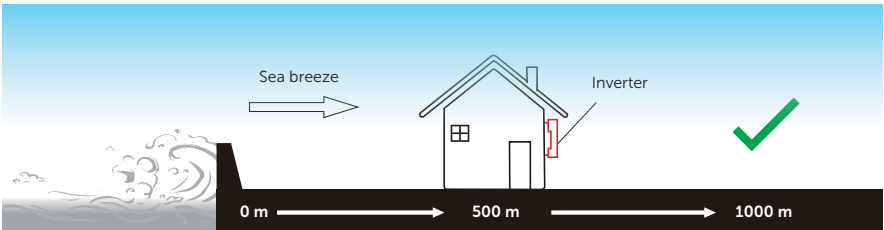

Figure 5-1 Recommended installation position

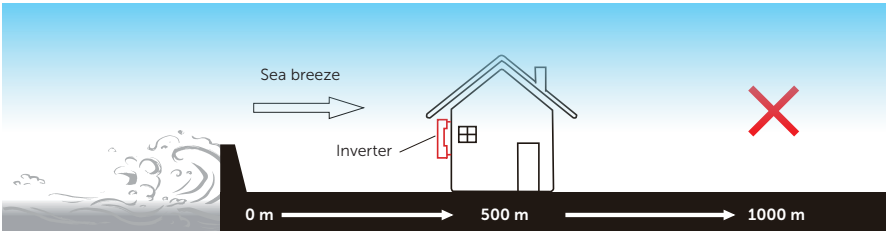

Figure 5-2 Incorrect installation position

NOTICE!

- For the installation of the whole system, please refer to the specific environment requirement of each unit.

5.1.2 Installation Carrier Requirement

The installation carrier must be made of a non-flammable material, such as solid brick, concrete, etc. and be capable of supporting the weight of the inverter and suitable of the dimensions of the inverter. If the wall strength is not enough, (such as wooden wall, the wall covered by thick layer of decoration) it must be strengthened additionally.

Please take the weight of battery into account when wall-mounting the whole system.

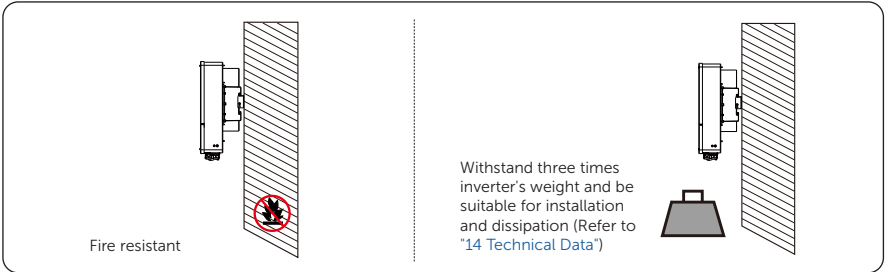

Figure 5-3 Installation carrier requirement

5.1.3 Clearance Requirement

The minimum clearance reserved for the connected terminal at the bottom of inverter should be 10 cm. When planning installation space, it is important to simultaneously consider the bending radius of the wires.

To guarantee proper heat dissipation and ease of disassembly, the minimum space around the inverter must meet the standards indicated below.

If you choose stack installation, please refer to the installation separation distance below. In areas with high ambient temperatures, increase the clearances between the inverters and provide adequate fresh air ventilation if feasible.

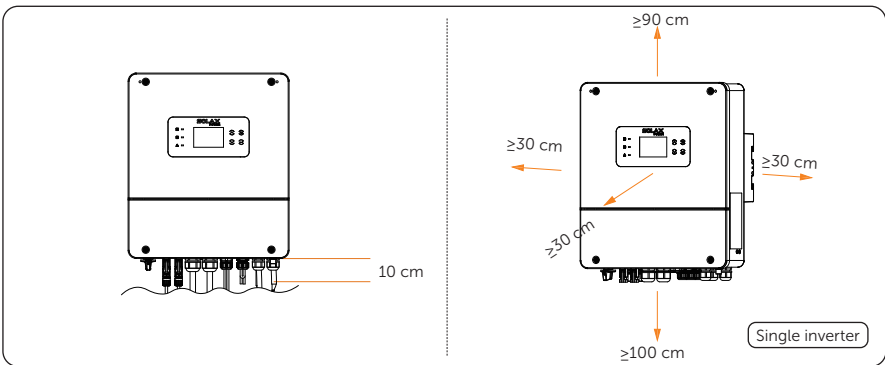

Figure 5-4 Clearance requirement for single inverter

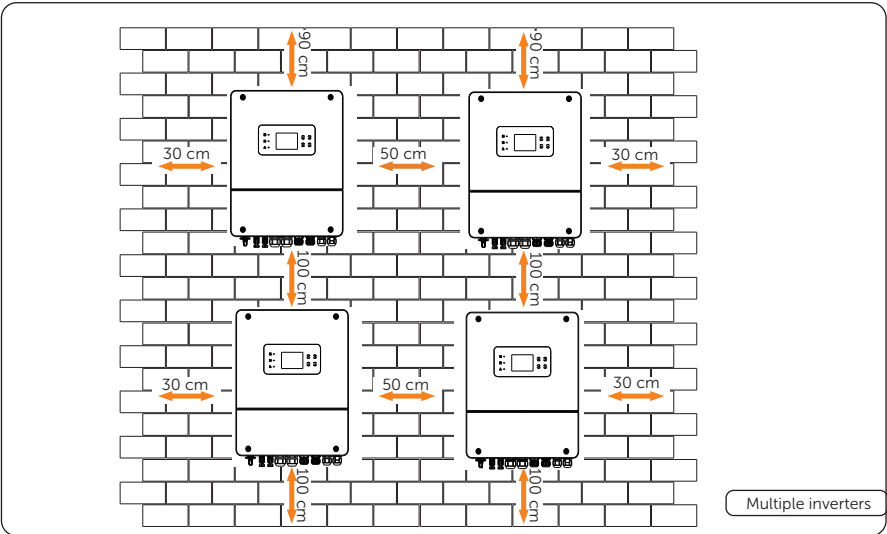

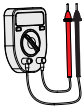
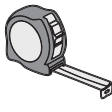



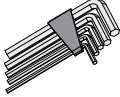

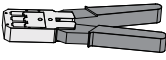
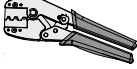

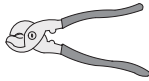
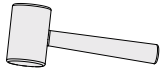
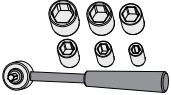





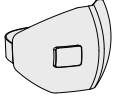

Figure 5-5 Clearance requirement for multiple inverter

5.2 Tools Requirement

Installation tools include but are not limited to the following recommended ones. If necessary, use other auxiliary tools on site.

 Hammer drill	 Multimeter	 Measuring tape	 Utility knife
 Marker	 Cross screwdriver	 Flat-head screwdriver	 Allen key
 Wire stripper	 Crimping tool for RJ45	 Crimping tool for PV terminals	 Diagonal pliers
 Crimping tool	 Crimping tool for ferrules	 Wire cutter	 Rubber mallet
 Torque wrench	 Spirit level	 Heat gun	 Φ6 mm Heat shrink tubing
 Safety gloves	 Safety boots	 Safety goggles	 Anti-dust mask

5.3 Additionally Required Materials

Table 5-2 Additionally required wires





No.	Required Material	Type	Conductor Cross-section
1	PV wire	 Dedicated PV wire with a voltage rating of 600 V	4 mm ²
2	Communication wire 1	 Network cable CAT5E	0.2 mm ²
3	Additoinal PE wire	 Conventional yellow and green wire	4 mm ² -10 mm ²
4	Battery power cable	 Conventional copper wire	16-25mm ² or 35-50 mm ²

Table 5-3 Grid cable and micro-breaker recommended

Model	X1-HYB-3.0-LV	X1-HYB-3.7-LV	X1-HYB-4.0-LV	X1-HYB-4.6-LV	X1-HYB-5.0-LV	X1-HYB-6.0-LV
Cable (copper)	4-6 mm ²	6-8 mm ²	6-8 mm ²	8-10 mm ²	8-10 mm ²	8-10 mm ²
Circuit breaker	32 A	40 A	40 A	50 A	50 A	50 A

Table 5-4 EPS cable and micro-breaker recommended

Model	X1-HYB-3.0-LV	X1-HYB-3.7-LV	X1-HYB-4.0-LV	X1-HYB-4.6-LV	X1-HYB-5.0-LV	X1-HYB-6.0-LV
Cable (copper)	3-4 mm ²	3-4 mm ²	3-4 mm ²	4-6 mm ²	4-6 mm ²	6-8 mm ²
Micro-Breaker	25 A	25 A	25 A	32 A	32 A	40 A

Table 5-5 GEN cable and micro-breaker recommended

Model	X1-HYB-3.0-LV	X1-HYB-3.7-LV	X1-HYB-4.0-LV	X1-HYB-4.6-LV	X1-HYB-5.0-LV	X1-HYB-6.0-LV
Cable (copper)	3-4 mm ²	3-4 mm ²	3-4 mm ²	4-6 mm ²	4-6 mm ²	6-8 mm ²
Micro-Breaker	25 A	25 A	25 A	32 A	32 A	40 A

6 Unpacking and Inspection

6.1 Unpacking

- The inverter undergoes 100% testing and inspection before shipping from the manufacturing facility. However, transport damage may still occur. Before unpacking the inverter, please check the outer packing materials for damage, such as holes and cracks.
- Unpacking the inverter according to the following figure.

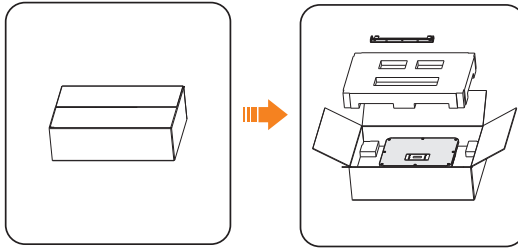

Figure 6-1 Unpacking the inverter

- Be careful when dealing with all package materials which may be reused for storage and relocation of the inverter in the future.
- Upon opening the package, check whether the appearance of the inverter is damaged or lack of accessories. If any damage is found or any parts are missing, contact your dealer immediately.

6.2 Scope of Delivery

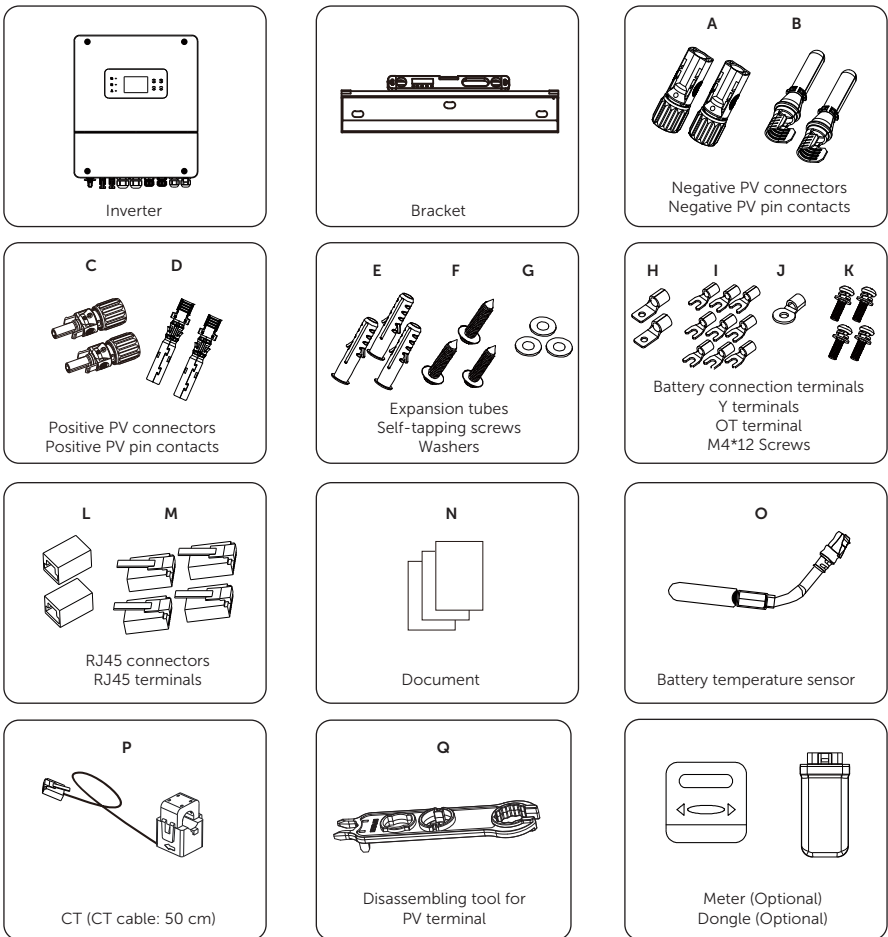

Table 6-1 Packing list

Item	Description	Quantity
/	Inverter	1 pc
/	Wall mounting bracket	1 pc
A	Negative PV connectors	2 pcs
B	Negative PV pin contacts	2 pcs
C	Positive PV connectors	2 pcs

Unpacking and Inspection

Item	Description	Quantity
D	Positive PV contacts	2 pcs
E	Expansion tubes	3 pcs
F	Self-tapping screws	3 pcs
G	Washers	3 pcs
H	Battery connection terminals	2 pcs
I	Y terminals	9 pcs
J	OT terminal	1 pc
K	M4*12 Screws	4 pcs
L	RJ45 connectors	2 pcs
M	RJ45 terminals	4 pcs
N	Document	/
O	Battery temperature sensor	1 pc
P	CT (CT cable: 50 cm)	1 pc
Q	Disassembling tool for PV terminal	1 pc
/	Dongle (Optional)	1 pc
/	Meter (Optional)	1 pc

NOTICE!

- Please refer to the actual delivery for the optional accessories.
- The figures of packing list take X1-Hybrid-3.0-LV inverter as an example.

7 Mechanical Installation

WARNING!

- Only the qualified personnel can perform the mechanical installation following the local standards and requirements.
- Check the existing power cables or other piping in the wall to prevent electric shock or other damage.

CAUTION!

- Always be aware of the weight of the inverter. Personal injuries may result if the inverter is lifted improperly or dropped while being transported or mounted.
- Use insulated tools when installing the inverter. Personal protective equipment must be worn during installation and maintenance.

NOTICE!

- Install the inverter at a maximum back tilt of 5 degrees and avoid forward tilted, side tilted, or upside down.

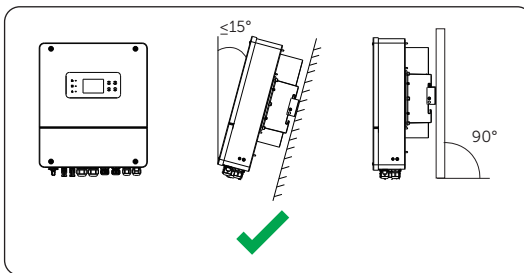

Figure 7-1 Correct installation

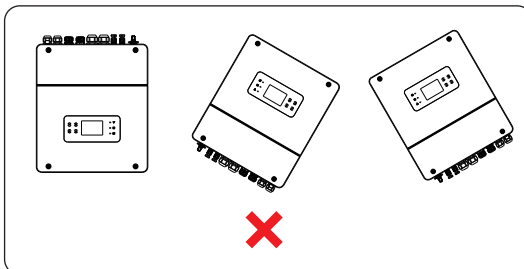

Figure 7-2 Incorrect installation

7.1 Dimensions for mounting

Check the dimensions of the wall mounting bracket before mounting and reserve sufficient space for heat dissipation and installation of the whole system.

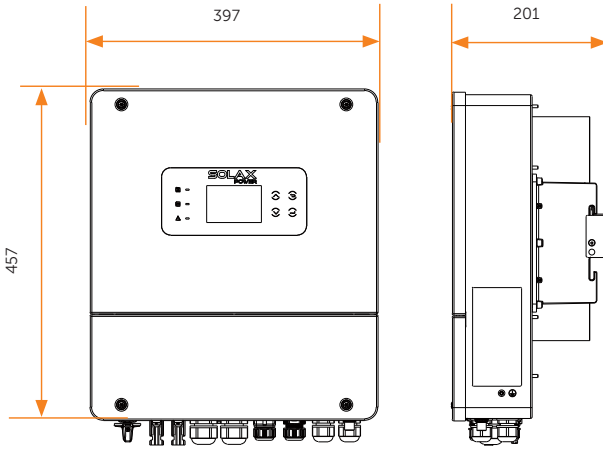

Figure 7-3 Dimensions 1 (Unit: mm)

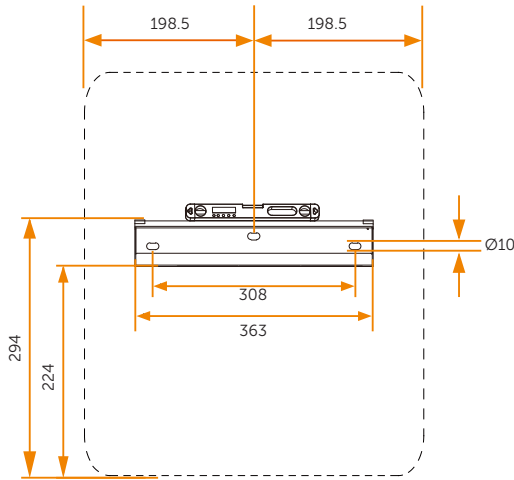

Figure 7-4 Dimensions 2 (Unit: mm)

7.2 Installation procedures

Step 1: Align the wall mounting bracket horizontally on the wall and mark the position of the drill holes.

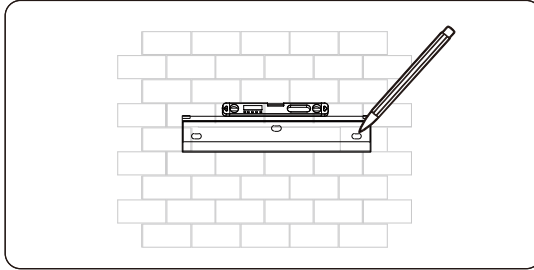

Figure 7-5 Marking the holes

NOTICE!

- Take the height of the battery into account when mounting the wall mounting bracket.
- Observe the bubble of spirit level and adjust the wall mounting bracket until the bubble stays in the middle.

Step 2: Set the wall mounting bracket aside and drill holes with $\text{Ø}10$ drill bit. The depth of the holes should be greater than 80 mm. The Hammer drill needs to be 90° perpendicular to the wall when using it. Do cover the inverter before drilling holes and clean up any dust in and around the holes using a dust collector.

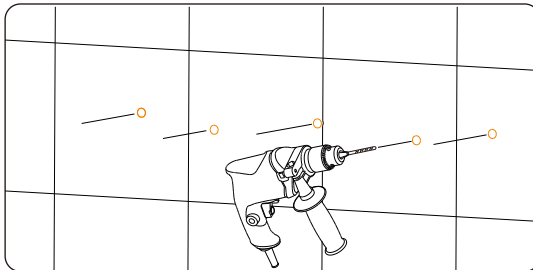

Figure 7-6 Drilling holes

Step 3: Attach the wall mounting bracket on the wall again. Insert the expansion tubes (Part E) into the holes and secure the wall bracket to the wall with self-tapping screws (Part F) .

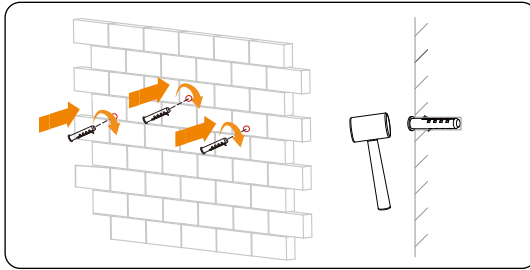

Figure 7-7 Insert the expansion tubes

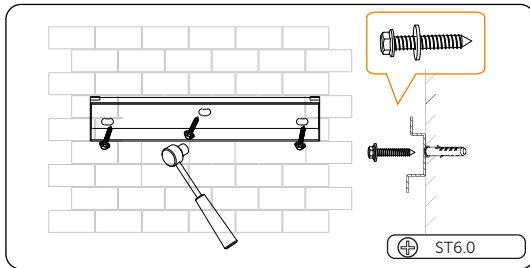

Figure 7-8 Securing the wall mounting bracket

Step 4: Open the anti-static bag and take out the machine.

Step 5: Lift up the inverter by three installers and hang it on the wall mounting bracket. The keyways of the inverter must be hooked into the buckles of wall mounting bracket.

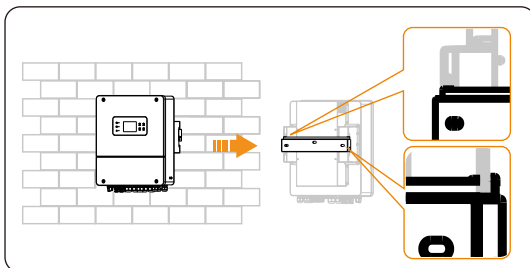

Figure 7-9 Hanging the inverter

Step 6: Secure the inverter to the wall mounting bracket with M4 screws. Tighten the M4*12 screws (Part K) on both sides.

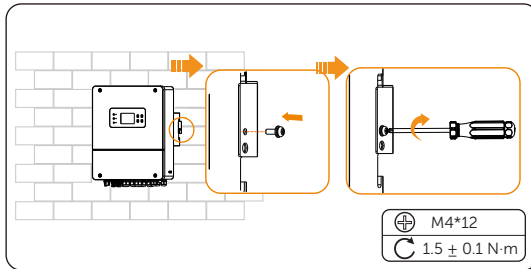

Figure 7-10 Securing the inverter

NOTICE!

- If the inverter is temporarily needed to be placed on the ground, use foam or other protective materials to prevent any damage of inverter.

8 Electrical Connection

DANGER!

- Before electrical connection, make sure the DC switch and AC breaker are disconnected. Otherwise, electrical shock may be caused by high voltage, resulting in serious personal injury or death.

WARNING!

- Only the qualified personnel can perform the electrical connection following the local standards and requirements.
- Follow this manual or other related document to wire connection. The inverter damage caused by incorrect cabling is not in the scope of warranty.

CAUTION!

- Use insulated tools and wear individual protective tools when connecting cables.

8.1 Terminals of Inverter

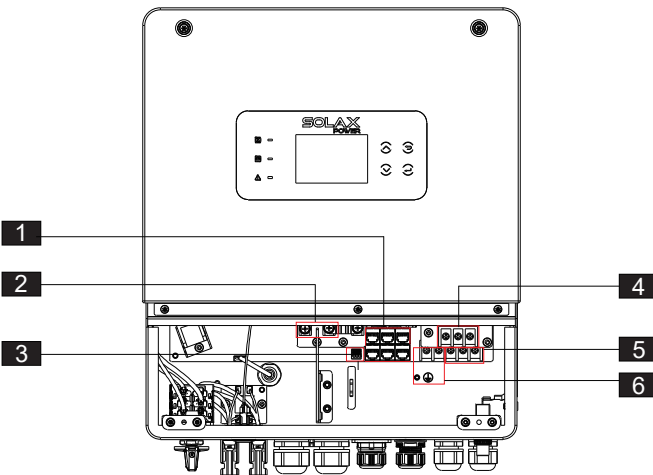

Figure 8-1 Terminals of Inverter (Front perspective view)

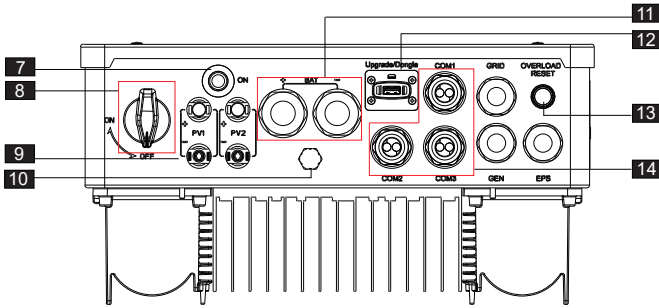

Figure 8-2 Terminals of Inverter (Bottom view 1)

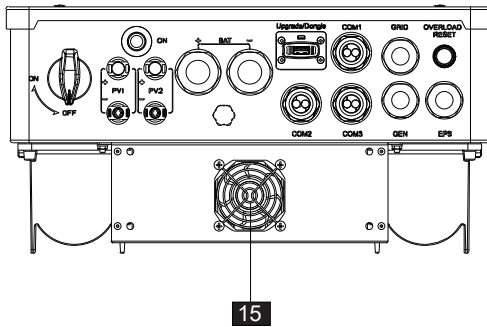



Figure 8-3 Terminals of Inverter (Bottom view 2)

Table 8-1 Description of terminals

Item	Description
1	Communication ports
2	Battery input connectors
3	Dry-contact output
4	Grid
5	EPS
6	Generator input
7	Battery power on button
8	DC Switch
9	PV input with two MPPT

Item	Description
10	Waterproof valve
11	BAT+/BAT-
12	USB port for upgrading/External monitoring connection port
13	Overload reset button
14	COM1/COM2/COM3 (for communication connection)
15	Fan (Only for X1-Hybrid-5.0-LV and X1-Hybrid-6.0-LV)

8.2 PE Connection

All non-current carrying metal parts of the equipment and other enclosures in the PV system must be grounded reliably. The PE point at the AC output terminal is used only as a PE equipotential point, not a substitute for the PE point on the enclosure. The connection point has been labeled with the following label:  We recommend that the inverter is earthed to a nearby ground point.

PE connection procedures

Step 1: Prepare a one-core cable (4-10 mm²), and then find the OT terminal (Part J) in the accessories. Strip the grounding cable insulation (length:10-12 mm).

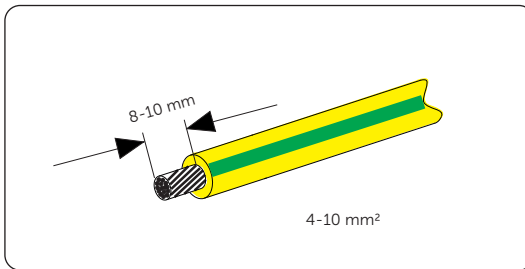

Figure 8-4 Stripping the PE cable
Table 8-2 PE cable recommended

Model	X1-HYB-3.0-LV	X1-HYB-3.7-LV	X1-HYB-4.0-LV	X1-HYB-4.6-LV	X1-HYB-5.0-LV	X1-HYB-6.0-LV
PE Cable	4-6 mm ²	6-8 mm ²	6-8 mm ²	8-10 mm ²	8-10 mm ²	8-10 mm ²

NOTICE!

- When AC cable $\leq 16 \text{ mm}^2$, the earthing conductor should be as thick as the AC cable..

Step 2: Pull the heat-shrink tubing over the PE cable and insert the stripped section into the OT terminal.

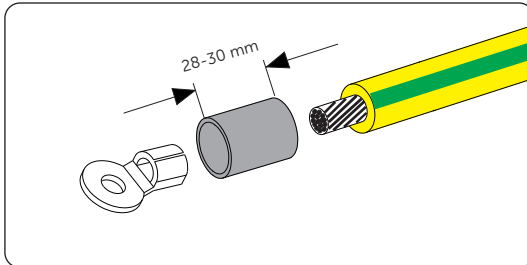

Figure 8-5 Installing the tubing and OT terminal

Step 3: Crimp it with crimping tool, pull the heat-shrink tubing over the stripped section of the OT terminal and use a heat gun to shrink it so that it can be firmly contacted with the terminal.

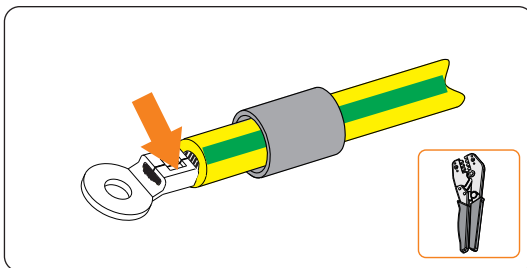

Figure 8-6 Crimping the cable

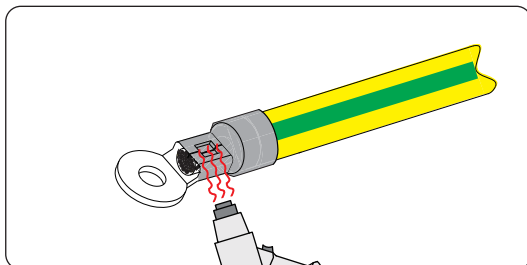

Figure 8-7 Shrinking the tubing

Step 4: Find the ground connection port on the inverter, loosen the PE screw on the inverter with cross screwdriver and screw the ground wire on the inverter with a cross screwdriver.

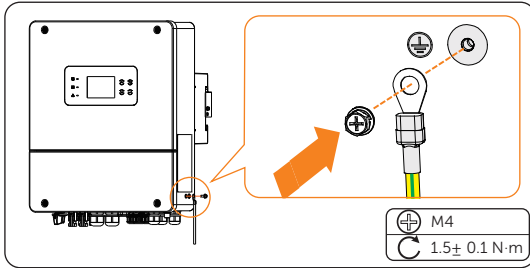

Figure 8-8 Securing the PE cable

8.3 AC Connection

NOTICE!

- The series inverter is a single-phase inverter suitable for rated voltages of 220/230/240V and frequencies of 50/60Hz. For more technical requirements, please consult the regulations of the local public grid.
- A circuit breaker should be installed between the inverter and the mains, and the load should not be directly connected to the inverter.

The series inverters have an integrated EPS (Emergency Power Supply) function. When the grid is connected, the inverter outputs flow through the Grid port; when the grid is disconnected, the inverter outputs flow through the EPS port.

Please refer to "2.5.2 Application Schemes" for wiring information.

To ensure compatibility with all loads, additional accessories are required. Please Refer to "5.3 Additionally Required Materials". If you need a solution, please contact our sales.

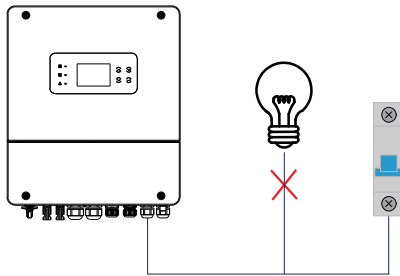

Figure 8-1 Wrong connection of load and inverter

EPS load requirements

The following table shows some common loads for your reference. Please check with the manufacturer for high-power inductive loads.

Table 8-3 Description of terminals

Content	Power		Common equipment	Instance		
	Start	Rated		Equipment	Start	Rated
Resistive load	X 1	X 1	Incandescent lamp	100W Incandescent lamp	100VA (W)	100VA (W)
Inductive load	X 3~5	X 2	Fan Fridge	150W Fridge	450-750VA (W)	300VA (W)

WARNING!

- Ensure that the EPS load's rated power is within the EPS rated output power range; otherwise, the inverter will report an overload warning.
- If an overload occurs, adjust the load power to ensure it is within the EPS rated output power range, and the inverter will automatically return to normal operation.
- For non-linear loads, ensure that the inrush current power is within the EPS rated output power range.

Grid, GEN and EPS connection steps

NOTICE!

- Please see "14 Technical Data" to check the grid voltage and compare with the voltage range.
- Remember to disconnect all power sources to prevent electric shock.

Step 1: Prepare a grid cable (triple-core cable), an EPS cable (triple-core cable), and a GEN cable (triple-core cable). Then, find the Y Terminals in the accessory bag. (Using X1-HYB-3.0-LV as an example)

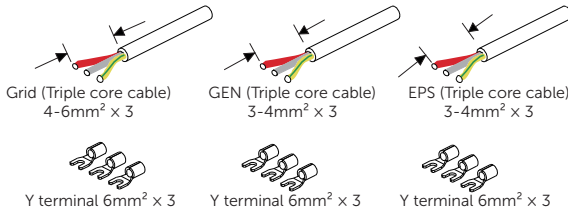

Figure 8-2 Stripping the Grid cable

NOTICE!

- Please refer to the table in 5.3 **Additionally required materials** to view the recommended wire sizes for GRID, EPS, and GEN.
- It is recommended to use copper wire. Non-triple or non-dual core cables shall be sealed with glue or fireproof mud.
- When using wire sizes of 6 mm² and above, only 2-core wires can be used because the 3-core wire cannot pass through the waterproof terminal. In the case of using 2-core wire, the PE wire should only be connected to the inverter shell and does not need to be connected to the internal terminals.
- All connection diagrams provided here are based on the use of a 3-core wire, with X1-HYB-3.0-LV serving as an example.

Step 2: Use a cross screwdriver to loosen the screws on both sides of the inverter. Remove the lower cover of the inverter.

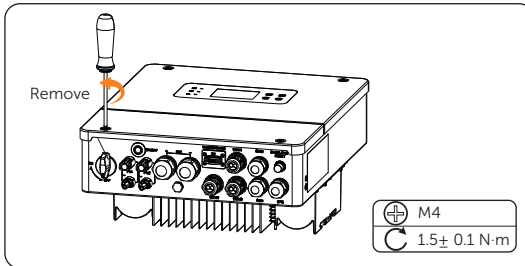

Figure 8-3 Loosen the screws

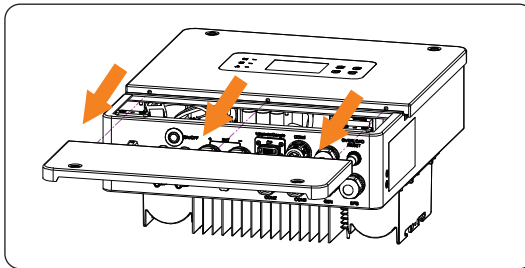

Figure 8-4 Remove the lower cover

Step 3: Remove the plug of Grid, GEN and EPS ports.

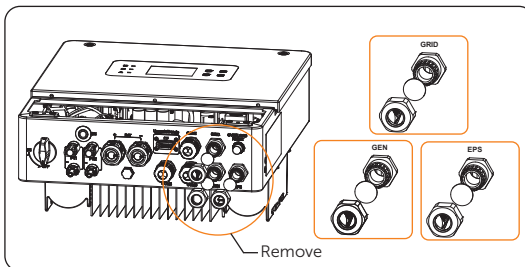

Figure 8-5 Remove the plug

Step 4: Find the location of the AC interface. The Grid, GEN, and EPS connection port are shown below.

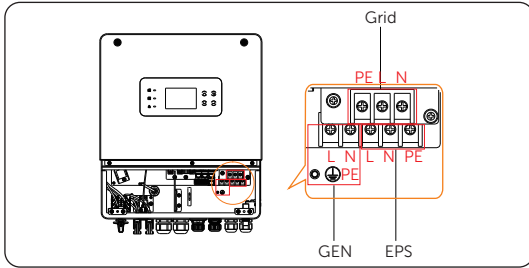

Figure 8-6 Find the Location

Step 5: Pass the previously prepared Grid, GEN and EPS cables through the corresponding screw caps and seals rings. The Grid, GEN, and EPS cables should go through the corresponding Grid, GEN, and EPS ports.

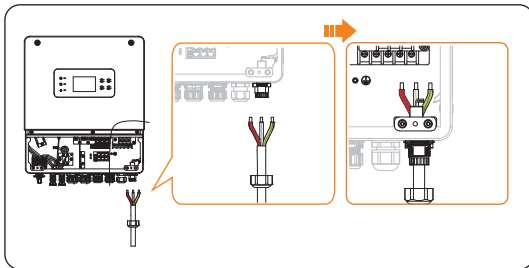

Figure 8-7 Pass the Grid cable

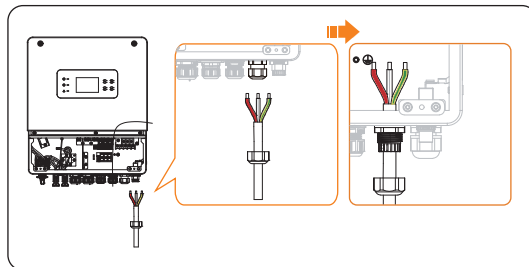

Figure 8-8 Pass the GEN cable

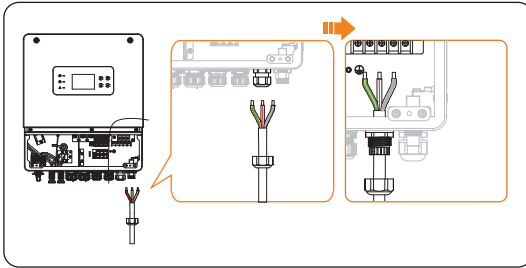

Figure 8-9 Pass the EPS cable

- Step 6:** Remove the 10 mm insulation layer at the end of the wire. Insert the Y terminals (Part I) respectively, and make sure that the stripped ends are inserted into the fork terminal, and finally use crimping pliers to press tightly.

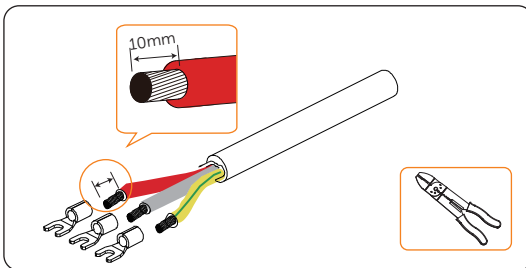

Figure 8-10 Remove the layer

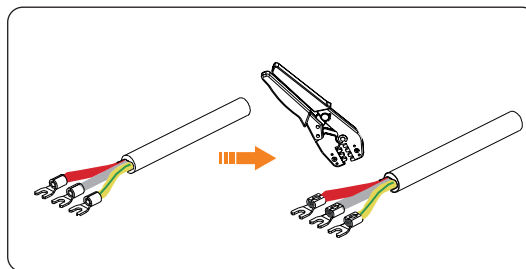

Figure 8-11 Insert and press the terminal

- Step 7:** Insert the crimped cables into the corresponding L, N, and PE terminals according to the wire sequence and tighten the screws with a cross screwdriver. Twist to tighten the screw caps and seals rings.

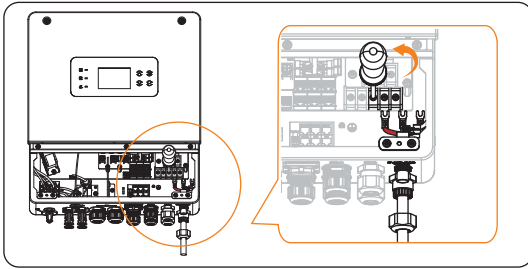

Figure 8-12 Insert the Grid cable

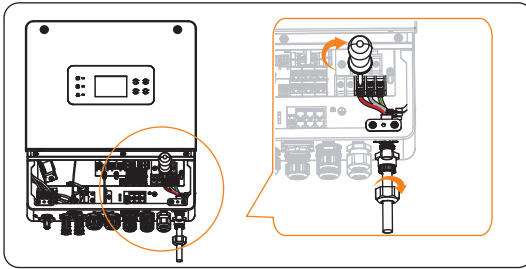

Figure 8-13 Tighten the Grid cable

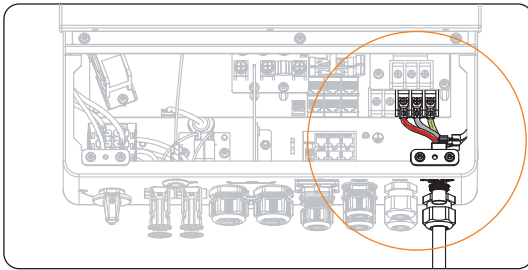

Figure 8-14 Grid cable connected

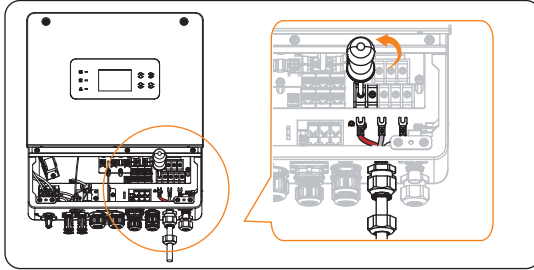

Figure 8-15 Insert the GEN cable

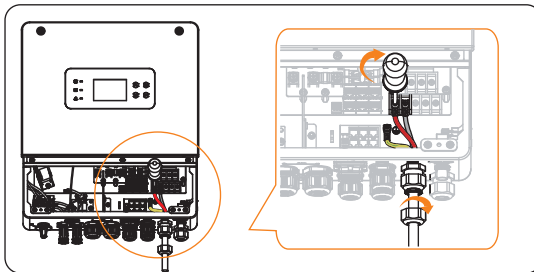

Figure 8-16 Tighten the GEN cable

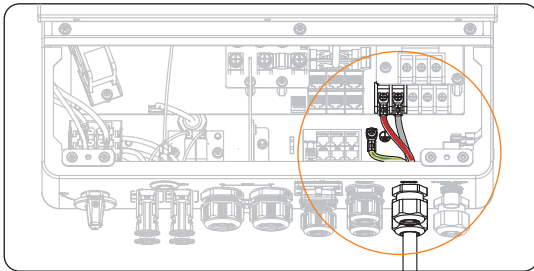

Figure 8-17 GEN cable connected

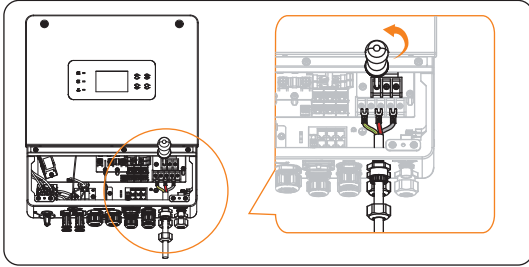

Figure 8-18 Insert the EPS cable

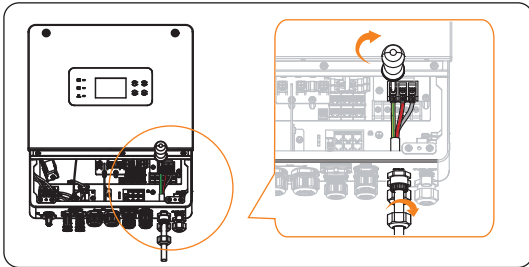

Figure 8-19 Tighten the EPS cable

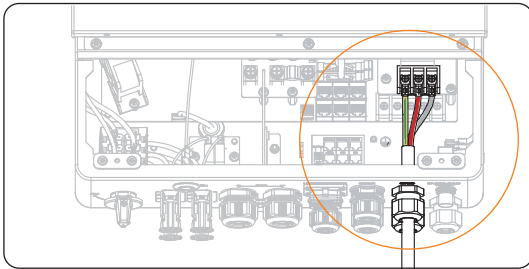

Figure 8-20 EPS cable connected

8.4 PV Connection

The series inverters have two PV inputs. Please select photovoltaic modules with good performance and quality assurance. The open circuit voltage of the module array should be less than the maximum PV input voltage specified by the inverter, and the working voltage should be within the MPPT voltage range.

Table 8-4 Voltage Data

Model	X1-HYB-3.0-LV	X1-HYB-3.7-LV	X1-HYB-4.0-LV	X1-HYB-4.6-LV	X1-HYB-5.0-LV	X1-HYB-6.0-LV
Max. PV input voltage				550V		
Start output voltage				110V		
Nominal input voltage				360V		
MPPT voltage range				80V ~ 520V		

DANGER!

- Photovoltaic modules operate at high and potentially dangerous voltages, so it is essential to follow safe electrical regulations when wiring them.
- High DC voltage will be generated by PV modules when exposed to sunlight. Death or lethal injuries will occur due to electric shock.
- Make sure the DC switch and AC breaker are disconnected from the inverter before connection.
- Make sure that the PV module output is well insulated to ground.

CAUTION!

- Do not ground the positive or negative pole of the photovoltaic module!

WARNING!

- To mitigate the risk of fire, it is crucial to utilize a dedicated crimping tool specifically designed for PV installations to ensure secure and reliable connections.

NOTICE!

- For each input range, the following PV module requirements must be met: same model, same quantity, and same angle.

Requirements for PV connection

- The series inverters support the following PV module connection modes.
 - » Method : Multi

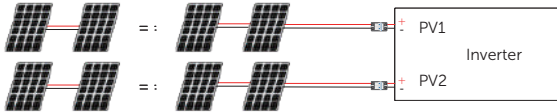

Figure 8-21 Striping the PV cable

Wiring procedures

Step 1: Turn off the DC switch, prepare a 4 mm² PV cable, and find the PV (+) connectors (Part A) and PV (-) connectors (Part C) in the package. Strip approx. 7 mm of the cable insulation.

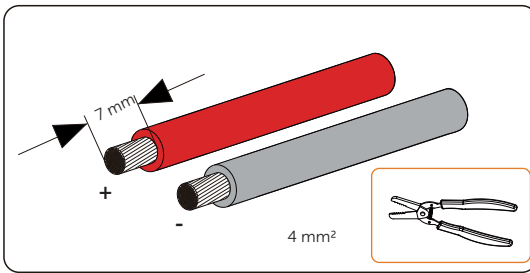

Figure 8-22 Striping the PV cable

Step 2: Insert the stripped cable into the PV pin contact (Part B and D) . Ensure that the stripped cable and the PV pin contact are of the same polarity. Crimp it with crimping tool for PV terminal.

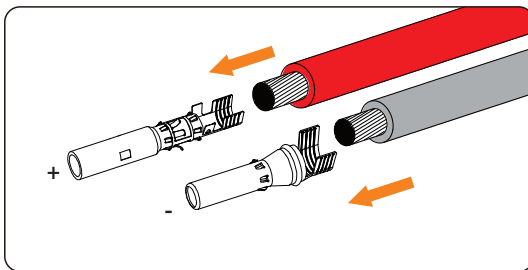

Figure 8-23 Inserting the PV pin contact

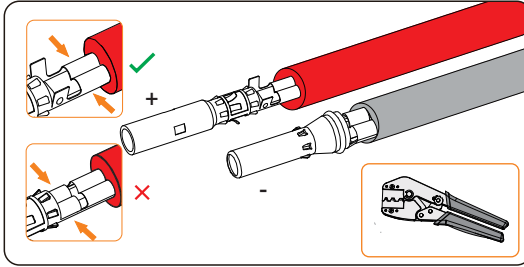

Figure 8-24 Crimping the terminal

WARNING!

- To mitigate the risk of fire, it is crucial to utilize a dedicated crimping tool specifically designed for PV installations to ensure secure and reliable connections.

Step 3: Thread the PV cable through swivel nut and insert the cable into the PV connector until a "Click" is heard. Gently pull the cable backward to ensure firm connection. Tighten the swivel nut clockwise. You can use the disassembling tool for PV terminal (Part Q) to secure or loose the swivel nut.

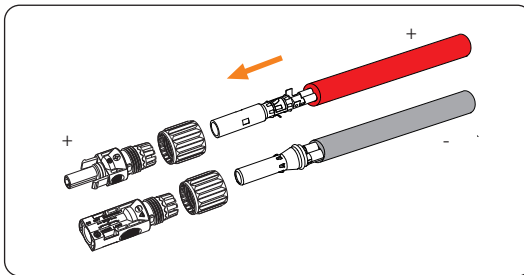

Figure 8-25 Threading the PV cable

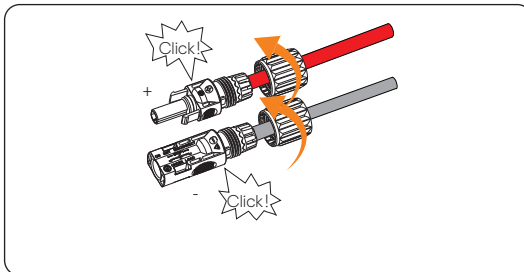

Figure 8-26 Securing the swivel nut

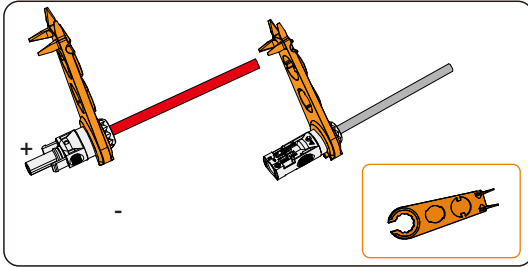

Figure 8-27 Loosening the swivel nut

Step 4: Use a multimeter to measure the positive and negative voltage of the assembled PV connectors. Make sure the open circuit voltage does not exceed the input limit of 500 V.

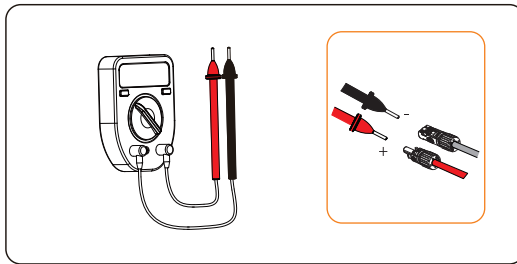

Figure 8-28 Measuring the voltage of PV connectors

NOTICE!

- If the voltage reading is negative, it indicates an incorrect DC input polarity. Please check if the wiring connections on the multimeter is correct or PV connectors are not mistakenly connected.

Step 5: Remove the PV terminal caps and connect the assembled PV connectors to corresponding terminals until there is an audible "Click". The PV+ on the string side must be connected to the PV+ on the inverter side, and the PV- on the string side must be connected to the PV- on the inverter side.

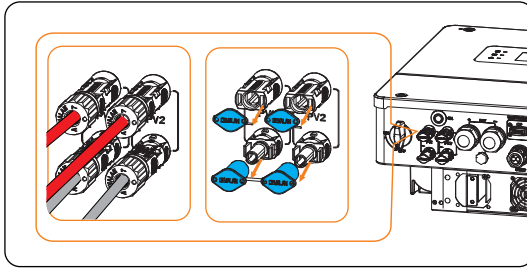

Figure 8-29 Connecting the PV cable

WARNING!

- Seal the unused PV terminals with original terminal caps. If all PV terminals are connected, keep the waterproof caps in a safe place. Reinstall it immediately after removing the connectors from terminals.

Disassembling the PV cable

Use the disassembling tool for PV terminal to disassemble it. Then remove the PV cable, and slightly pull it out.

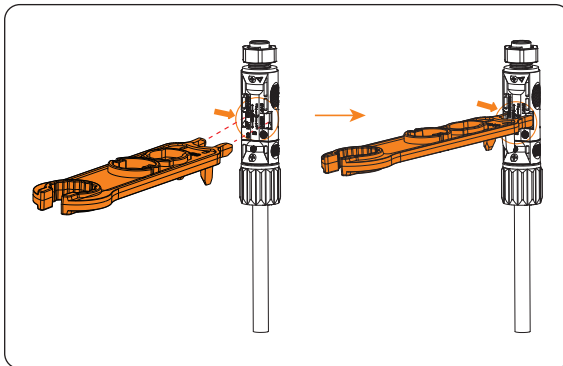

8.5 Battery Power Cable Connection

8.5.1 Battery connection

- Battery tconnection diagram

Model	X1-HYB-3.0-LV	X1-HYB-3.7-LV	X1-HYB-4.0-LV	X1-HYB-4.6-LV	X1-HYB-5.0-LV	X1-HYB-6.0-LV
Recommended battery capacity (kWh)	3~4.5	3.7 ~ 5.55	4.0 ~ 6.0	4.6 ~ 6.9	5.0 ~ 7.5	6.0 ~ 9.0

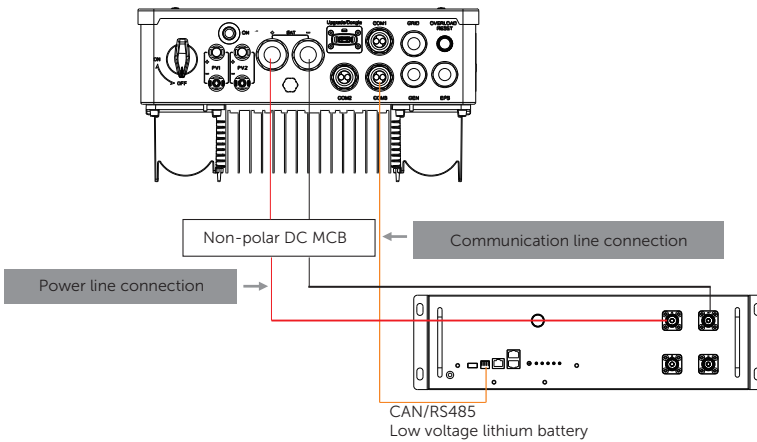

Figure 8-30 Battery connection diagram

Requirments for battery connection

- Required battery
 - » The series inverter system can be equipped with low voltage lithium battery and lead acid battery.
- Battery Breaker
 - » Before connecting the battery, a non-polar DC MCB must be installed to ensure safety.
 - » Before maintenance, the inverter need to be safely disconnected.

Model	X1-HYB-3.0-LV	X1-HYB-3.7-LV	X1-HYB-4.0-LV	X1-HYB-4.6-LV	X1-HYB-5.0-LV	X1-HYB-6.0-LV
Voltage	Nominal voltage of DC breaker should be larger than maximum voltage of battery.					
Current[A]	100 A			150 A		

⚠ DANGER!

- Make sure the breaker, power button (if any) and DC switch (if any) of battery is OFF.
- Always ensure correct polarity. Never reverse the polarity of the battery cables as this will result in inverter damage.

NOTICE!

- Please ensure that the BAT power line and BMS communication line are correctly connected when using the low-voltage batteries TP-LR25 and TP-LR36. Check T-BAT LR25 & T-BA LR36 Installation Manual for details.

Battery connection steps

Step 1: Prepare a 16-25 mm² or 35-50 mm² battery power cable. Strip approx. 10 mm of the cable insulation.

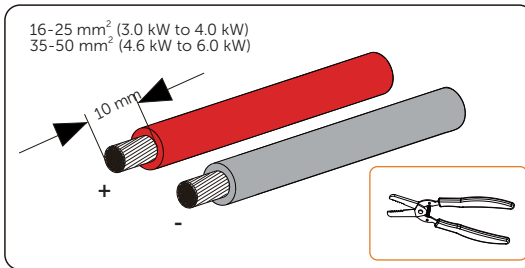

Figure 8-31 Stripping the battery cable

Step 2: Insert the stripped cables into the Battery connection terminals (Part H) respectively and crimp the terminals tightly.

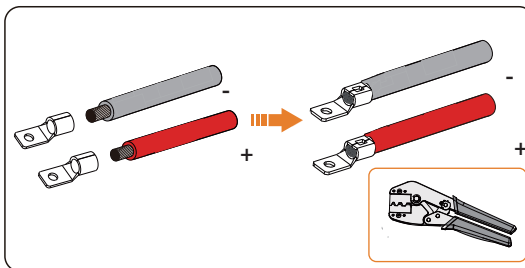

Figure 8-32 Insert the terminal

Figure 8-33

Step 3: Loosen the waterproof connector.

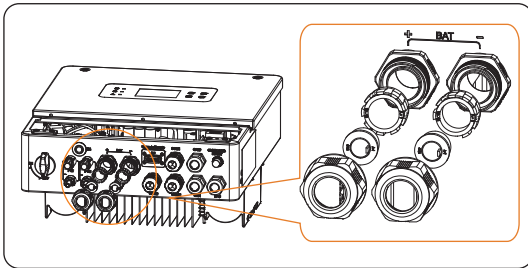

Figure 8-34 Connecting the battery connector

- For battery connection from 3.0 kW to 4.0 kW

Step 4: Remove the sealing cover of the plug.

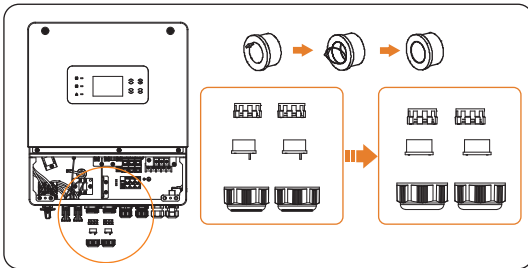

Figure 8-35 Remove the sealing cover

Step 5: Pass the previously assembled cables through the corresponding swivel nut. Find the battery interface, insert the positive cable into BAT+ port and the negative cable to BAT-port.

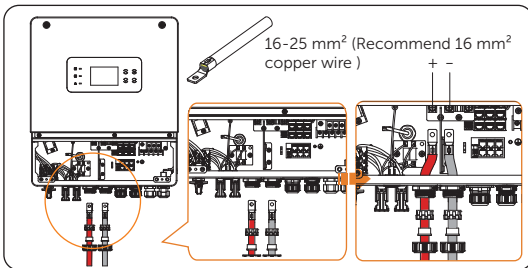

Figure 8-36 Pass and insert the cable

Step 6: Find the battery interface, remove the screw. insert the positive cable into BAT+ port and the negative cable to BAT-port.

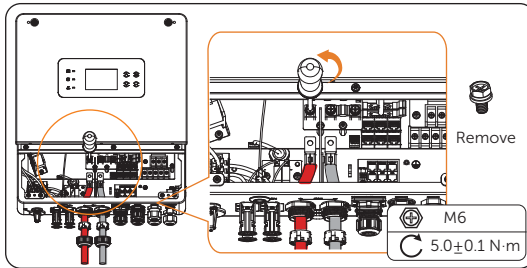

Figure 8-37 Remove the screw

Step 7: Use cross screwdriver to tighten the screw. Twist to tighten the swivel nut.

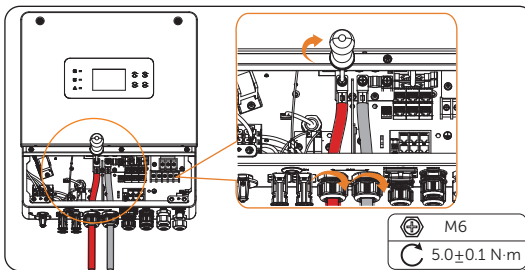

Figure 8-38 Tighten the cable

- For battery connection from 4.6 kW to 6.0 kW

Step 4: Remove the plug.

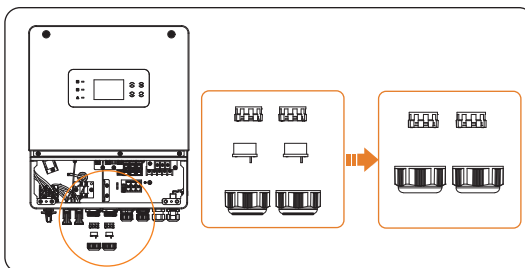

Figure 8-39 Remove the plug

Step 5: Pass the previously assembled cables through the corresponding swivel nut. Find the battery interface, insert the positive cable into BAT+ port and the negative

cable to BAT-port.

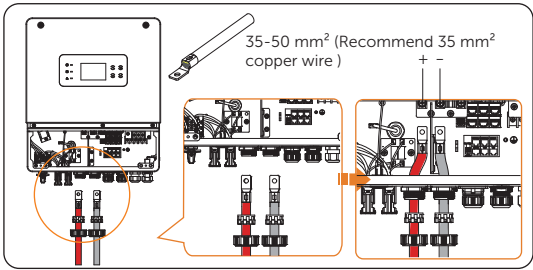

Figure 8-40 Pass and insert the cable

Step 6: Find the battery interface, remove the screw. insert the positive cable into BAT+ port and the negative cable to BAT-port.

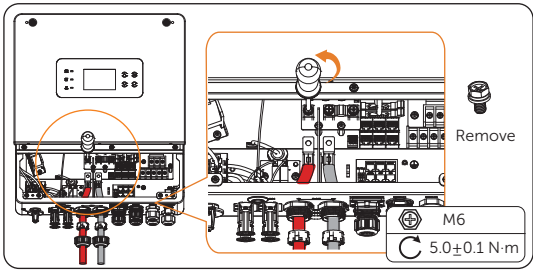

Figure 8-41 Remove the screw

Step 7: Use cross screwdriver to tighten the screw. Twist to tighten the swivel nut.

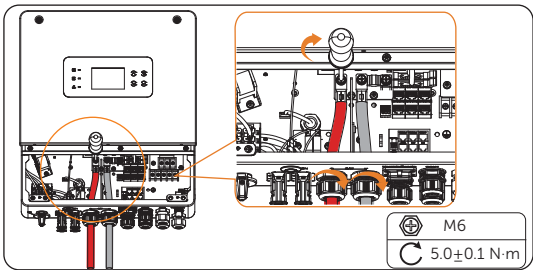

Figure 8-42 Tighten the cable

! WARNING!

- Keep the terminal caps in a safe place if batteries are connected to the inverter.
- Reinstall the caps immediately after removing the connectors from terminals.

NOTICE!

- If only the battery is connected but the PV, GRID, and GEN are not connected, to start the inverter, press and hold the battery power on button until the screen is on.

8.5.2 Battery temperature sensor connection

- Battery temperature sensor connection diagram

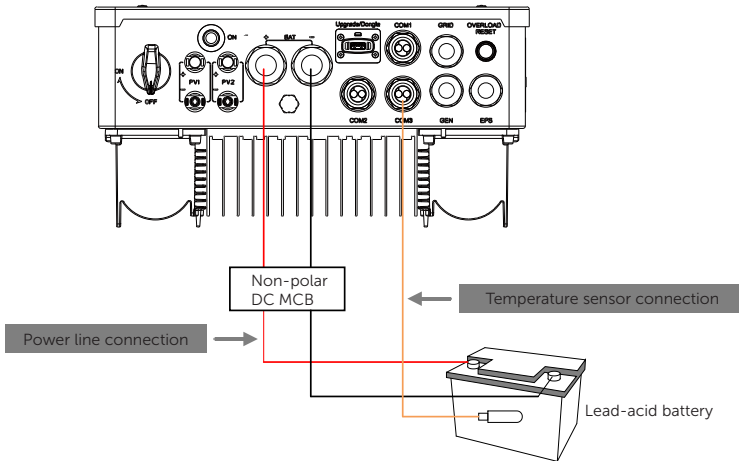

Figure 8-43 Battery temperature sensor connection diagram

Battery temperature sensor connection steps

- Step 1:** Find the battery temperature sensor (Part O) in the accessory bag.
- Step 2:** Disassemble the swivel nut on COM1/2/3. Pass the battery temperature sensor through the COM port and insert the RJ45 connector of the battery temperature sensor into the BMS port located inside the inverter. You can select any port from COM1/2/3.

Step 3: Attach the terminal at the other end to the lead-acid battery in order to measure the battery temperature.

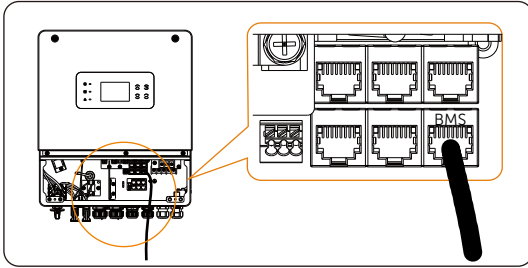

Figure 8-44 Insert the cable into the BMS port

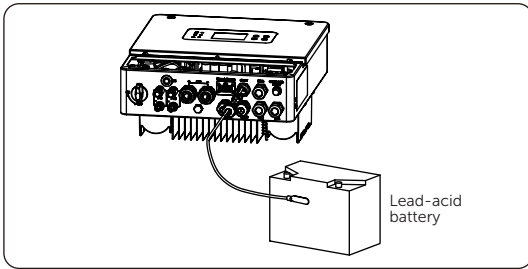

Figure 8-45 Attach the terminal

8.6 Communication Connection

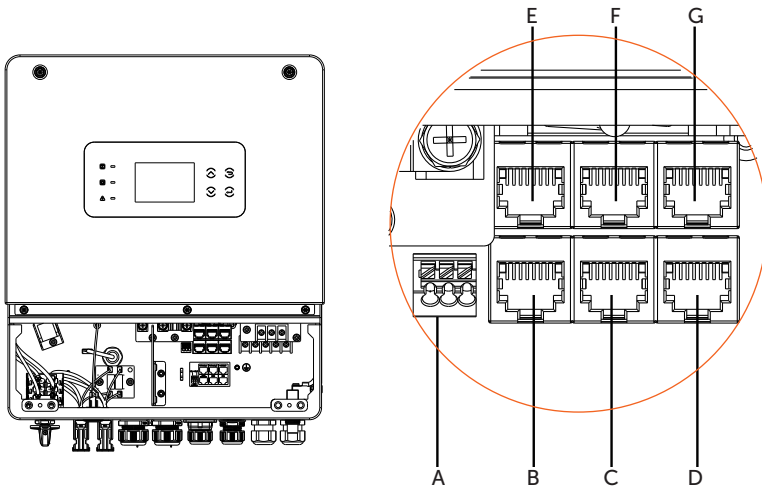

Figure 8-46 Communication ports

Table 8-5 Definition of communication ports

Number	Description
A	Dry-contact output
B	DRM(optional)
C	COM
D	BMS
E	Parallel_1
F	Parallel_2
G	Meter/CT

8.6.1 CT/meter port connection

The inverter should work with an electric meter or current sensor (CT for short) to monitor household electricity usage. The electricity meter or CT can transmit the relevant electricity data to the inverter or platform, which is convenient for users to read at any time.

Users can choose to use electric meters or CTs according to their demand. Please note that the meter/CT brand required by us must be used.

Users can also customize the length of the CT communication cable and the NTC cable (battery temperature sensor). The accessory package provides two RJ45 connectors.

When the CT cable is completed, connect the A terminal to the METER/CT port inside the inverter and securely tighten the waterproof screw. Connect the B terminal to the RJ45 terminal.

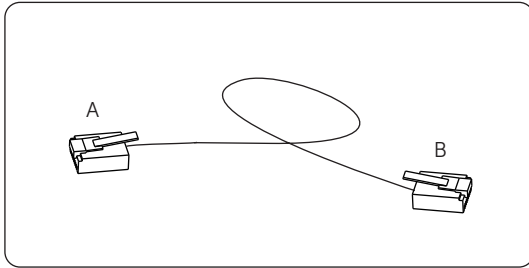

Figure 8-47 customize the CT cable

NOTICE!

- The meter or CT must be connected to the inverter; otherwise, the inverter will shut down and trigger a "meter failure" alarm. Smart meters must be authorized by us, third-party, or other companies. Unauthorized meters may be incompatible with the inverter.
- Our company will not be responsible for the impact caused by the use of other appliances.

CT connection diagram

The current sensor measures the current on the live wire between the inverter and the public grid.

- CT connection diagram

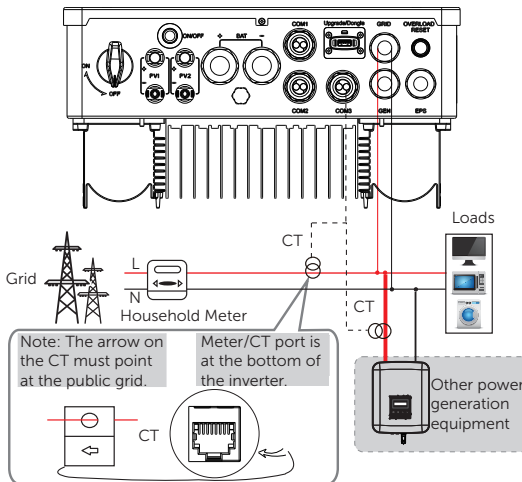

Figure 8-48 CT connection diagram

CT/Meter connection steps

Step 1: Remove the plug. For Communication connection, you can select any port from COM 1, COM 2 and COM3.

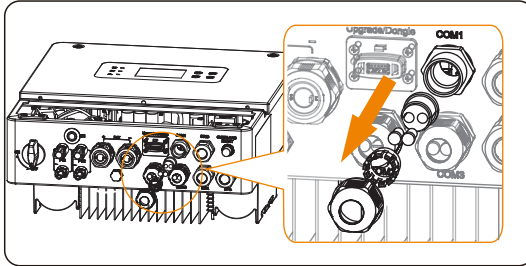

Figure 8-50 Remove the plug

Step 2: For meter connection, crimp only one RJ45 terminal (Part M) .
For CT connection without RJ45 connector, there is no need to crimp another RJ45 terminal.
For CT connection with RJ45 connector, crimp two RJ45 terminal.

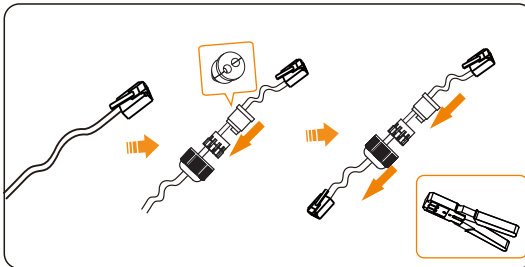

Figure 8-51 Crimp the terminal

NOTICE!

- it is recommended to use CAT5 Cable.

Step 3: For meter connection, insert one side of the cable (with no terminal) into the inverter, and the other side of the cable into the waterproof distribution box.

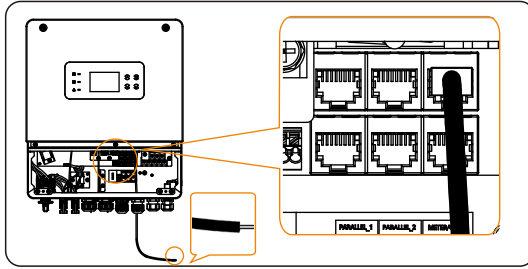

Figure 8-52 Insert one side of the cable into the inverter

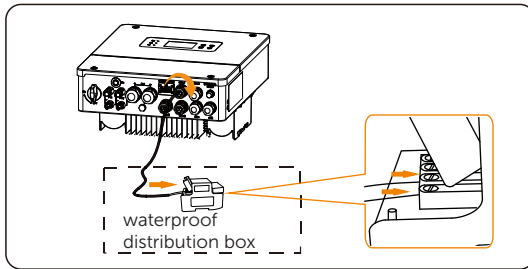

Figure 8-53 Insert the other side of the cable into the waterproof distribution box

Step 4(a): For CT connection without RJ45 connector, insert one side of the finished cable and the waterproof connectors with RJ45 into the Meter/CT port of the inverter, tighten the waterproof screw and insert the other side of the RJ45 terminal into the CT connection.

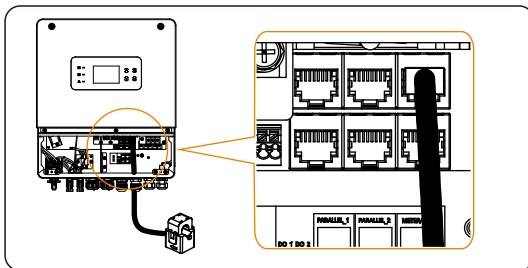

Figure 8-54 Insert one side of the cable into the inverter

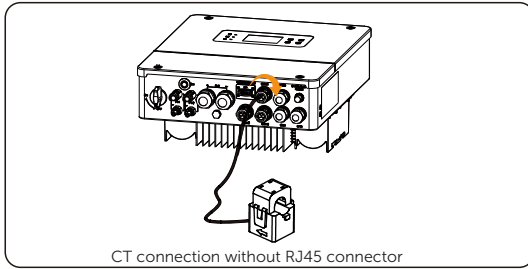

Figure 8-55 Insert the other side of the cable into the CT connection

Step 4(2): For CT connection with RJ45 connector, connect the A terminal to the Meter/CT port of the inverter, tighten the waterproof screw and connect the B terminal to the RJ45 connector (Part L) .

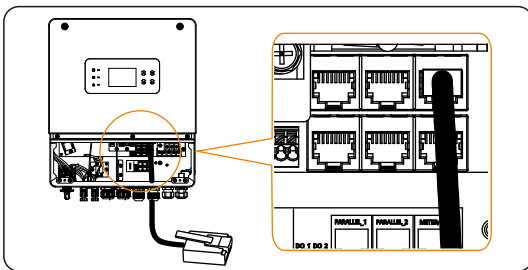

Figure 8-56 Connect the A terminal

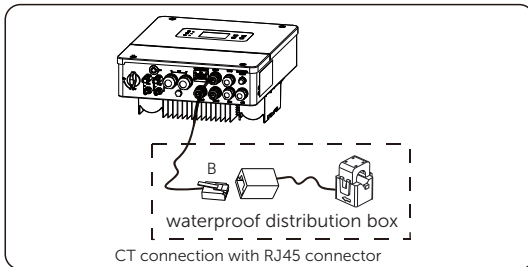

Figure 8-57 Connect the B terminal

NOTICE!

- When installing, pay attention to water resistance. All the connected parts of the CT must be placed into the distribution cabinet.
- Do not place the CT on the N wire or ground wire.
- Do not put the CT on both the N line and L line at the same time.
- Do not place the CT on the side where the arrow points to the inverter.
- Do not place the CT on non-insulated wires.
- After the CT is connected, prevent the CT clip from falling off.
- It is recommended to wrap the CT clip with insulating tape.

8.6.2 BMS/DRM/COM port connection

BMS port definition

- Lithium battery connection diagram

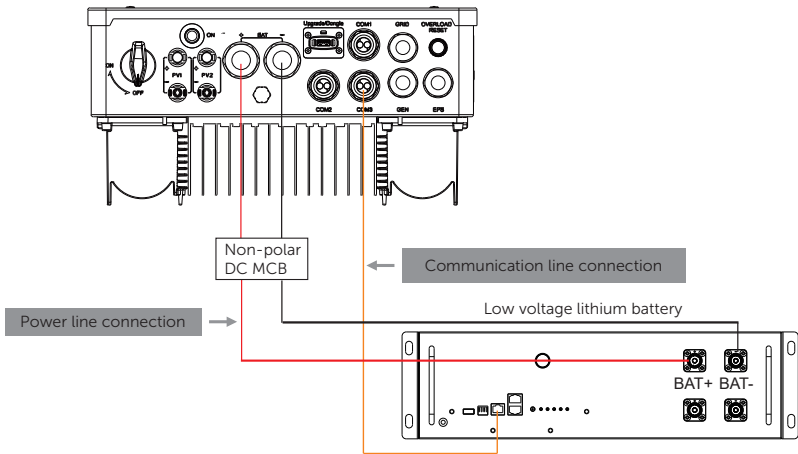

Figure 8-58 Lithium battery connection diagram

- Pin definition for BMS

Pin	1	2	3	4	5	6	7	8
Pin Definition	BMS_485B	BMS_485A	GND	BMS_CANH	BMS_CANL	X	GND	BAT_TEMP

NOTICE!

- The communication interface between the inverter and the battery uses the waterproof connector with RJ45.

DRM port definition (Only for Australia)

This inverter can support external control signal response, such as complying with AS4777 regulatory requirements.

Table 8-6 DRM mode

Mode	Requirements
DRM0	Operation disconnect device

- Pin definition for DRM

Pin	1	2	3	4	5	6	7	8
Pin Definition	DRM1/5	DRM2/6	DRM3/7	DRM4/8	RG/0	CL/0	X	X

COM communication definition

COM communication interface is mainly provided for customization the second step of development use. The inverter supports the control of external equipment or external equipment control through communication. For example, the inverter adjusts the working mode of the heat pump and so on.

- Pin definition for COM

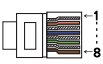

Pin	1	2	3	4	5	6	7	8
Pin Definition	Dry-contact_in1	Dry-contact_in2	X	RS485_A	RS485_B	GND	X	X

NOTICE!

- Customers can communicate or control the inverter and external devices through the COM interface. Professional users can use pins 4 and 5 to realize data acquisition and external control functions. The communication protocol is Modbus RTU. For details, please contact us.
- If the user wants to use the inverter dry contact to control external equipment (such as a heat pump), it can be used with our Adapter Box. Please refer to the quick installation manual of the Adapter Box for more details.

- Application occasion

COM is a standard communication interface, through which the monitoring data of the inverter can be directly obtained. Also, external communication devices can be connected to carry out the secondary development of the inverter. For specific technical docking, please contact us.

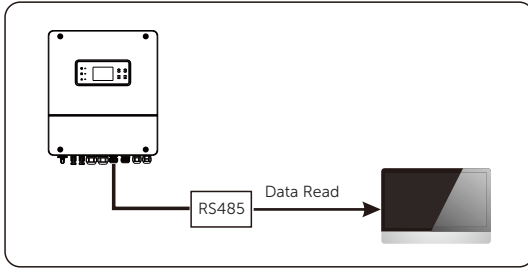

Figure 8-59 Application occasion: external communication

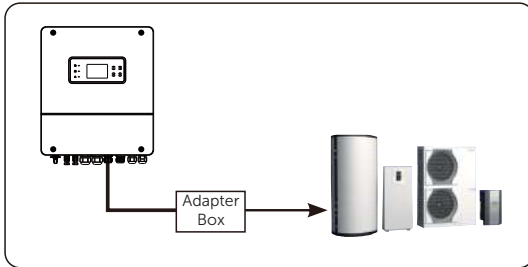

Figure 8-60 Application occasion: Inverter communication to control external equipment

BMS/DRM/COM connection steps

Step 1: Remove the plug. Pass the cable through the corresponding screw caps and seals rings. Strip the insulation layer (length: 15mm) at one end of the cable. Crimp a RJ45 terminal at the same end of the cable.

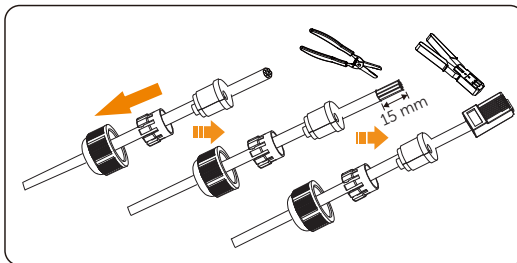

Figure 8-61 Prepare the cable

Table 8-7 CAT5 wiring order



1	White with orange stripes	5	White with blue stripes
2	Orange	6	Green
3	White with green stripes	7	White with brown stripes
4	Blue	8	Brown

NOTICE!

- It is recommended to use CAT5 Cable.
- Use network cable tester to test the crimped cable before connecting to the inverter.

Step 2: Find the DRM(optional), COM, BMS port. For communication connection, you can select any port from COM 1, COM 2 and COM 3. Insert the previously prepared cables into the corresponding ports.

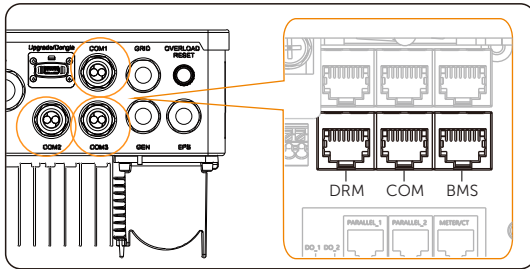

Figure 8-62 Find the DRM(optional), COM, BMS port

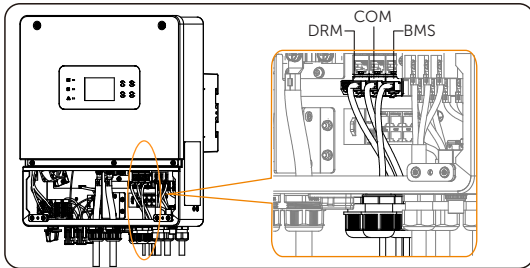

Figure 8-63 Insert the cable

NOTICE!

- After the BMS communication between the battery and the inverter is finished, the battery will work normally.

8.6.3 Parallel Connection

The series inverters provide parallel function, and up to 10 inverters can be connected in a system. In this system, one inverter is set as the “master inverter”, and the other inverter is switched to the “slave inverter” state, and the inverters are connected to communicate through the parallel line.

The parallel cable making method is the same as BMS/DRM/COM.

NOTICE!

- In parallel operation, if there are PV modules, the master inverter must be connected to the PV modules.

System diagram applicable with use of energy meter

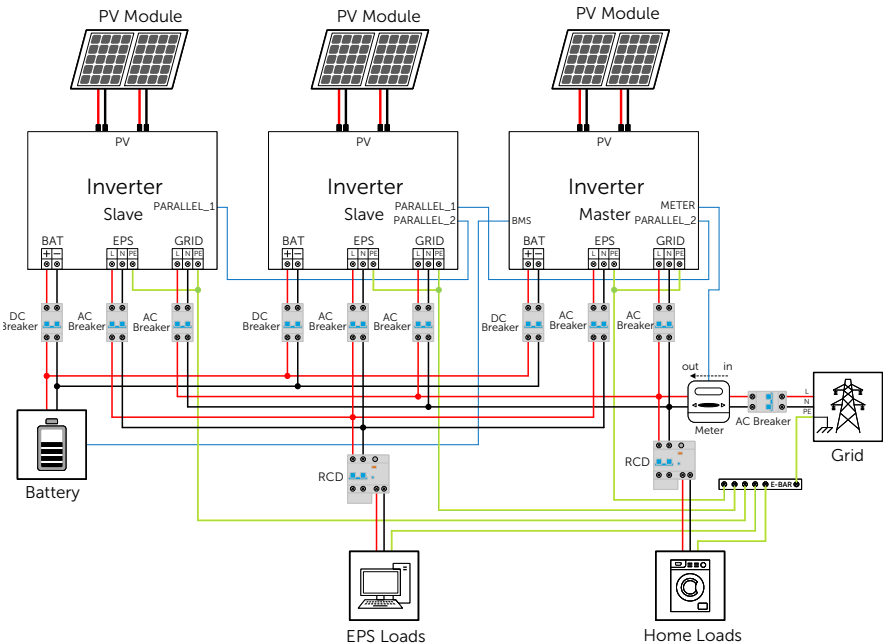

Figure 8-64 System diagram applicable with use of energy meter

System diagram applicable with use of current sensor (CT)

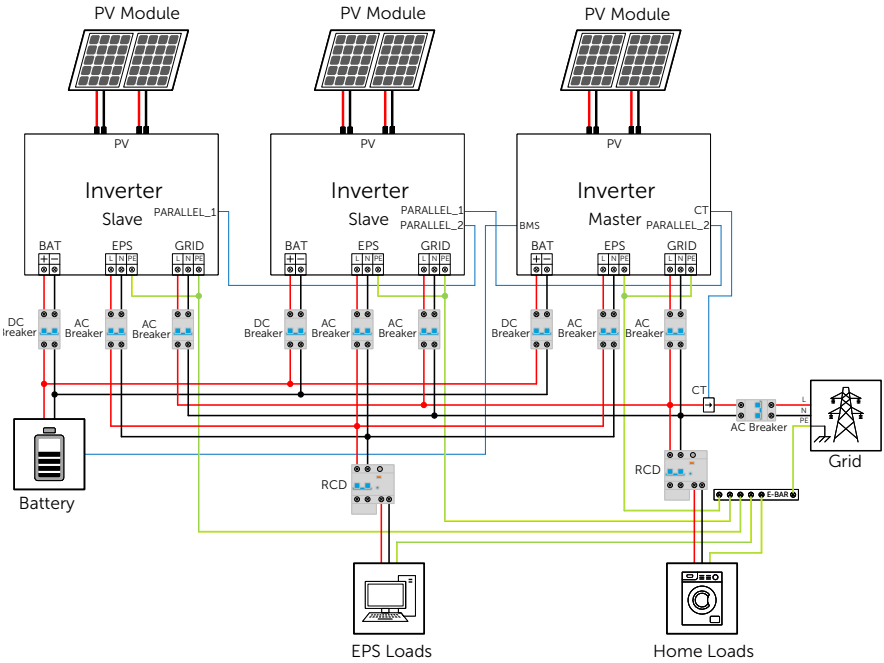

Figure 8-65 System diagram applicable with use of current sensor (CT)

Parallel connection diagram

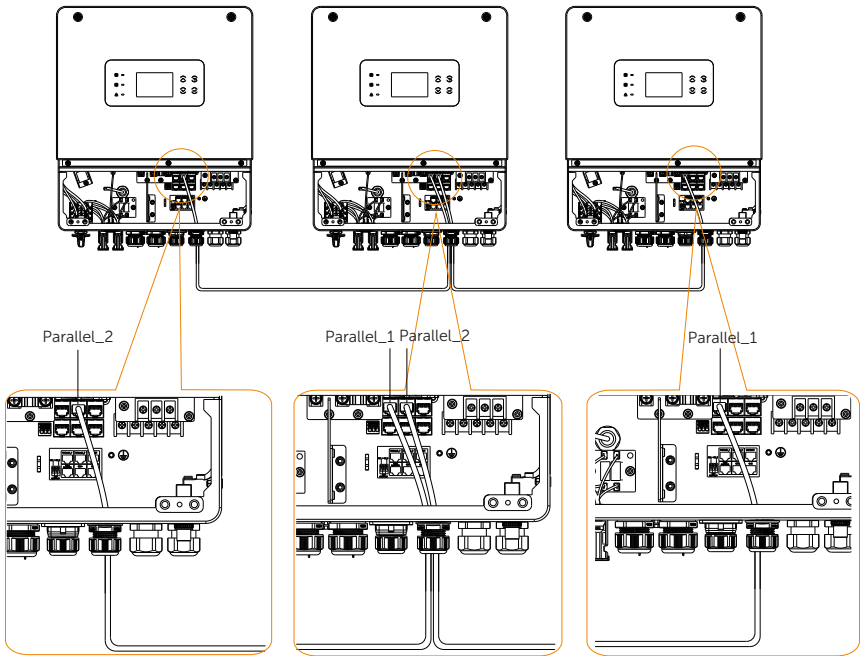

Figure 8-66 Parallel connection diagram

8.6.4 Dry-contact output connection

Dry-contact output connection diagram

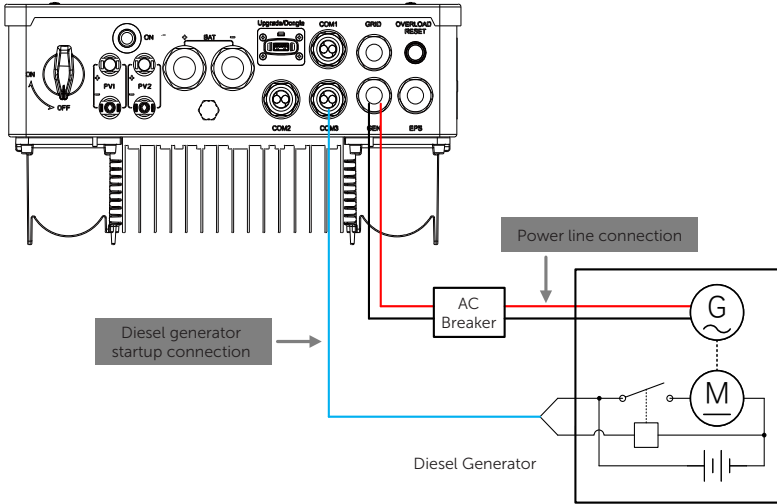

Figure 8-67 Dry-contact output connection diagram

Dry-contact definition

DO_1 and DO_2 are dry contact output ports that can be used to start external devices such as generators and adaptor boxes.

Dry-contact output connection steps

Step 1: Strip the insulation layer (length: 15mm) at one end of the cable. And cut off the 6 cables (length:6-8mm), keep the rest 2 cables.

For dry-contact output connection, you can select any two cables from the following four groups: white with orange stripes, Orange; white with green stripes, blue; white with blue stripes, green; white with brown stripes, brown.

NOTICE!

- It is recommended to use CAT5 Cable.
- Use network cable tester to test the crimped cable before connecting to the inverter.

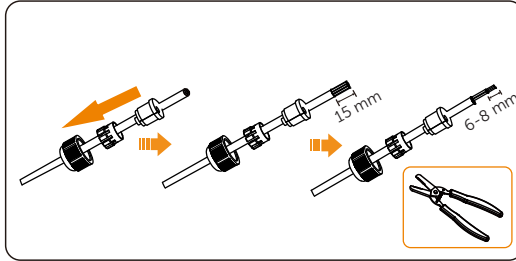

Figure 8-68 Prepare the cable

Table 8-8 CAT5 wiring order



1	White with orange stripes	5	White with blue stripes
2	Orange	6	Green
3	White with green stripes	7	White with brown stripes
4	Blue	8	Brown

NOTICE!

- It is recommended to use CAT5 Cable.
- Use network cable tester to test the crimped cable before connecting to the inverter.

Step 2: Find DO_1 and DO_2 port. For Communication connection, you can select any port from COM 1, COM 2 and COM3. Insert the prepared cable into the corresponding ports. .

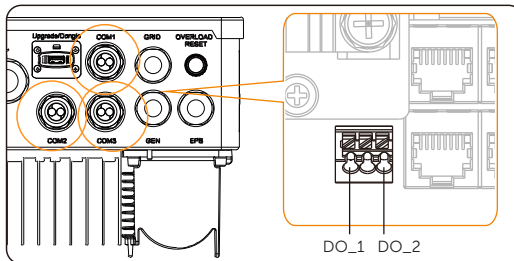

Figure 8-69 Find the port

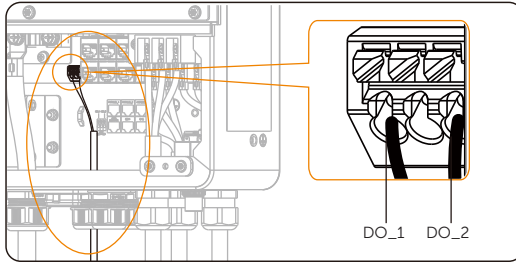

Figure 8-70 Insert the cable

Step 3: Slide to close the lower cover. Use cross screwdriver to tighten the screws on both sides of the inverter.

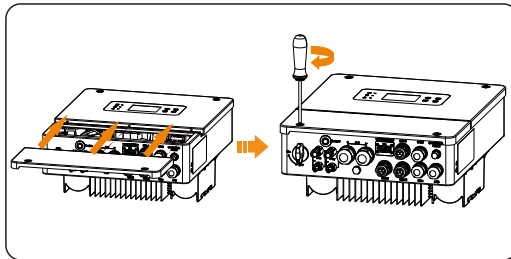

Figure 8-71 Close the lower cover and tighten the screws

8.7 Monitoring Connection

The inverter provides a DONGLE port, which can transmit data of the inverter to the monitoring website via WiFi Plus Dongle, 4G Dongle, and LAN Dongle. Users can choose based on actual needs. (If needed, purchase products from us.)

Monitoring connection diagram

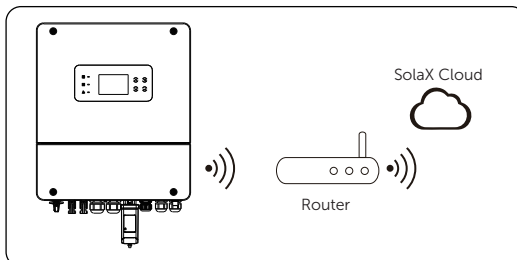

Figure 8-72 Wi-Fi mode connection diagram

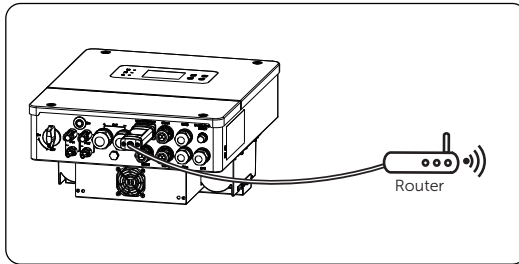

Figure 8-73 LAN mode connection diagram

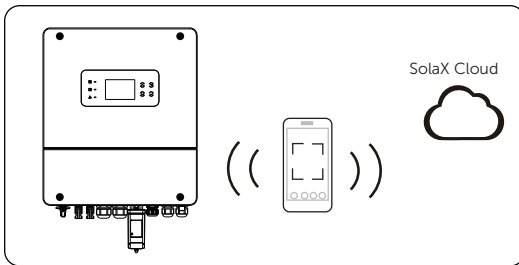

Figure 8-74 4G mode connection diagram

Monitoring wiring procedure

- WiFi mode:

Step 1: Assemble the dongle;

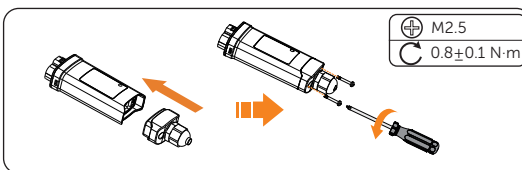

Figure 8-75 Assembling the dongle

Step 2: Plug the dongle to the inverter.

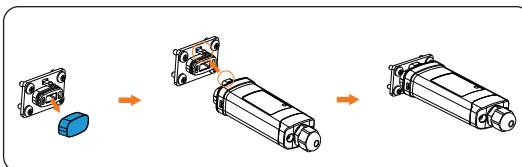

Figure 8-76 WiFi connection procedure

CAUTION!

- The buckles must be on the same side. Otherwise, the dongle may be damaged.

NOTICE!

- The longest connection distance between the router and the equipment should be no more than 100 meters; if there is a wall between the router and the equipment, the longest connection distance is 20 meters.
- When the WiFi signal is weak, please install a WiFi signal booster at the appropriate location.

NOTICE!

- Please refer to Pocket WiFi + LAN Installation Guide for instructions on configuring the WiFi. It is important to note that the WiFi configuration should be performed after powering on the inverter..

- **LAN mode:**

Step 1: Disassemble the waterproof connector into components 1, 2, 3 and 4; Component 1 is not used. Keep it in a safe place;

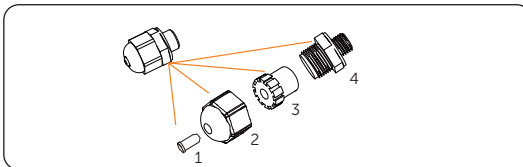

Figure 8-77 Disassembling the waterproof connector

Step 2: Assemble the dongle;

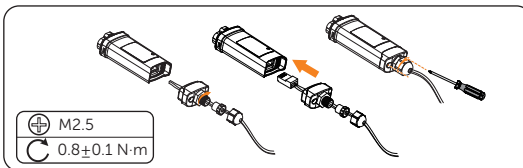

Figure 8-78 Assembling the LAN dongle

Step 3: Plug the dongle to the inverter.

9 System Commissioning

9.1 Checking before Power-on

- a. Check if the device installed correctly and securely;
- b. Make sure that all the DC breakers and AC breakers are OFF;
- c. All DC, AC cables and communication cables are connected correctly and securely;
- d. The ground cable is connected correctly and securely;
- e. Make sure the meter/CT is connected correctly and securely;
- f. Make sure the battery is connected correctly and securely;
- g. Make sure all photovoltaic panels are connected correctly and securely;
- h. Make sure the external AC and DC connectors are connected;
- i. Unused terminals and ports are locked by waterproof caps. All the screws are tightened.

9.2 Powering on the System

Step 1: Turn on the grid port load and EPS port load breaker

Step 2: Turn on the AC breaker between the inverter and wait for the inverter power on.

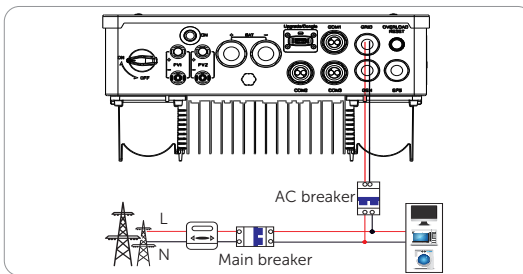

Figure 9-1 Turning on AC BREAKER

Step 3: Turn on the DC switch and check the LCD screen.

- » If the LCD screen is not on, turn off the DC switch and check whether the PV polarity is connected correctly.
- » If the error of any channel of PV is displayed on LCD, turn off the DC switch and check the corresponding channel of PV connection.

10 Operation on LCD

10.1 Introduction of Control Panel

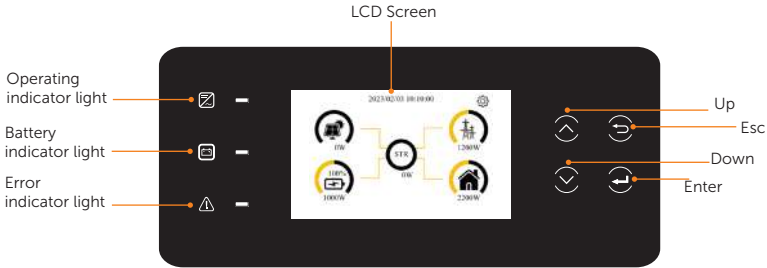

Figure 10-1 Control Panel of the inverter







* Please refer to the actual product for the color of the LCD screen.

Table 10-1 Definition of keys

Key	Definition
	ESC key Exit from the current interface or function
	Up key Move the cursor to the upper part or increase the value
	Down key Move the cursor to the lower part or decrease the value
	Enter key Confirm the selection

Table 10-2 Definition of indicators of Inverter

LED indicator	Status	Definition
		Solid green The inverter is in grid-connected operation state or off-grid operation state.
		Green blinking The inverter is in the process of grid connection or off-grid.
		Light off The inverter is in a fault or manual shutdown state.

 Battery		Solid blue	The battery is online and the voltage is normal.
		Light off	Low battery voltage or no battery.
 Error		Solid red	The inverter is in fault status.
		Red blinking	The inverter has alarm information.
		Light off	There are no faults and alarms in the inverter.

NOTICE!

- While upgrading, the green, blue and red indicator lights will flash in turns, indicating that the upgrade is in progress.

10.2 Screen Menu Structure

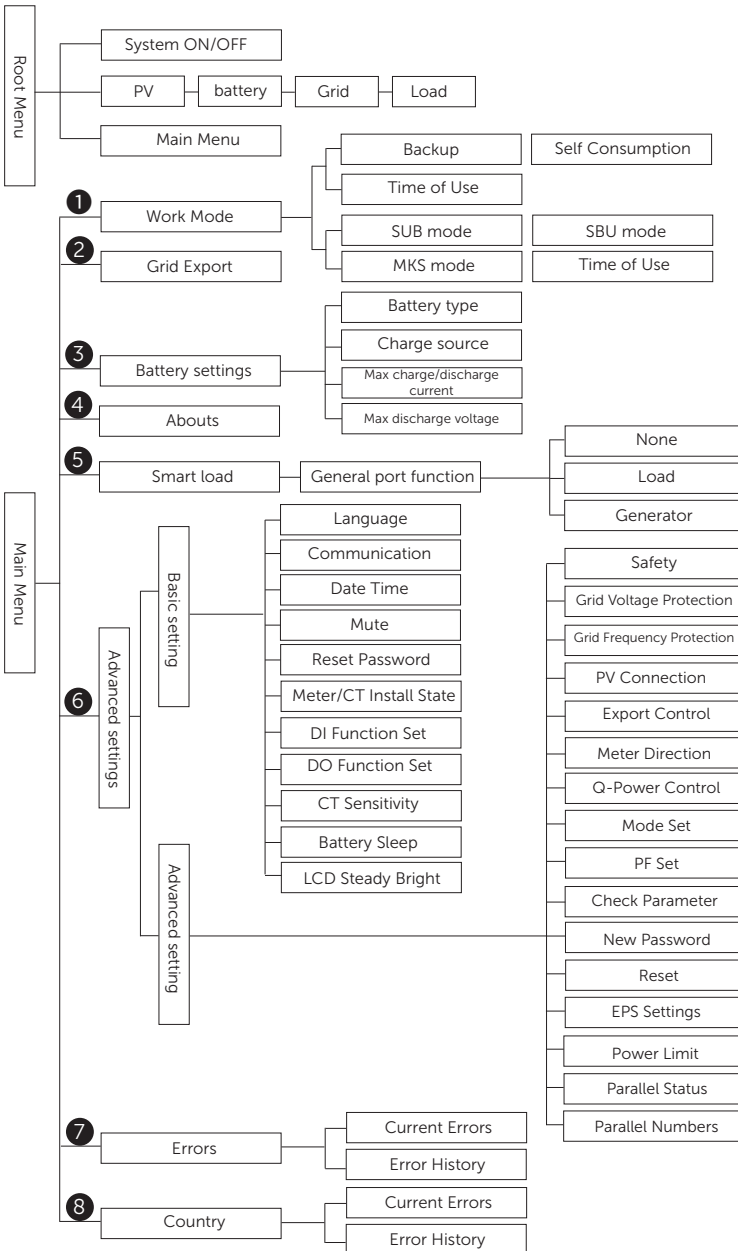

10.3 Settings

10.3.1 Root menu

Basic Settings

The root menu is the default interface, the inverter will automatically return to this interface when the system started up successfully or not operated for a period of time. The information of the interface is as below.

Users can tap on the four circles at the corners to access basic information including PV, battery, grid and load.

Tapping the "STR" button in the center will navigate to the Power On/Off settings. Users can tap the circles to check basic information of the inverter and battery. "Power On" indicates that the inverter is in working state, which is generally the default state. "Power Off" means that the inverter stops running and only the LCD screen is turned on. To set power on or off, users could tap the selection box and then press "√" to save the settings.

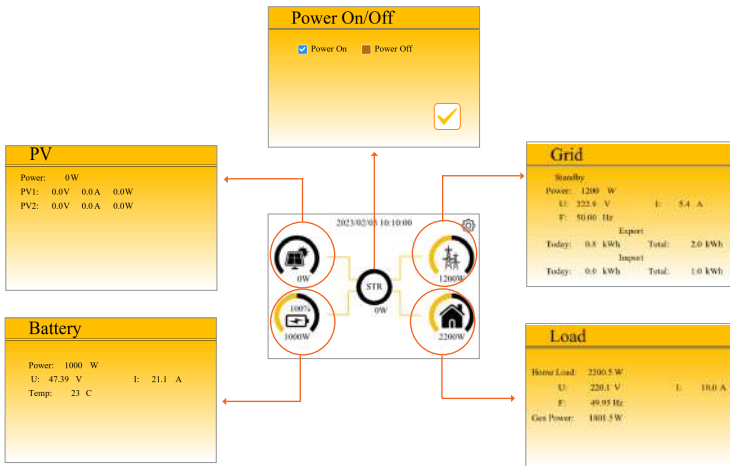

According to the operating conditions of the inverter, the root menu interface will also display differently.

- Inverter starting → Inverter already started, ready for operation

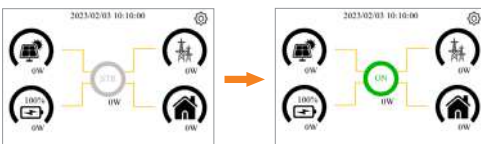

- Inverter off

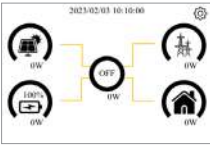

- Inverter error

If there is a fault currently, one of the faults will be displayed on the main interface. To view details, please enter Main menu "Inverter information" -> "Errors" to check the current and historical faults.

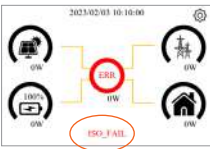

Line Color Explanation

The lines on this interface will also show the corresponding statuses of PV, battery, grid, and load.

Table 10-3 LCD Display Colored Line Explanation

Circuit	Status	Color
PV to Inverter	Electricity generating	Green
	Electricity not generating	Grey
Battery to Inverter	Discharging	Blue
	Stop charging or discharging	Grey
	Charging (from PV)	Green
	Charging (from Grid)	Red
	Charging (from PV and Grid)	Orange
Power grid to inverter	Power consuming	Red
	No power in the grid	Grey
	Grid feed-in (PV generation)	Green
	Grid feed-in (PV generation + battery discharge)	Orange

Load to inverter	Load consumption (from PV or battery)	Blue
	Load consumption (from grid)	Red
	Load consumption (from two sources among grid, PV, and battery)	Orange
	Load consumption (power grid, PV and battery supply power to the load at the same time)	Purple

10.3.2 Main menu

To enter the main menu, please tap the settings icon in the upper right corner. There are eight submenus in the menu that can be selected for relevant setting operations.



Work Mode

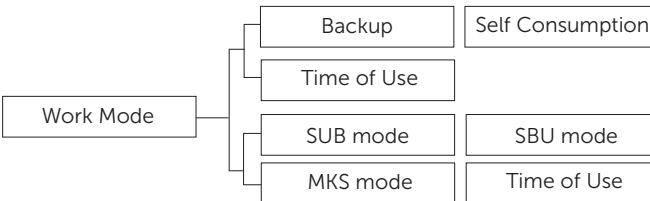

For mode selection, there are 3 or 4 working modes to choose from depending on different safety options. Please refer to 3.3 Work mode for detailed explanation.

To select the Pakistan work modes, please tap "Country" on the main menu and select "Pakistan". You can refer to "Country" section for details.

Note that the basic settings pages will be different when Pakistan are selected. Please refer to the basic settings section on next page for more details.

- Work mode for Pakistan



- Work mode for other countries



When "Time Of Use" mode is selected, there will be two interface pages for setting the charging period and discharging period. Users can switch between the two pages using the up and down buttons:

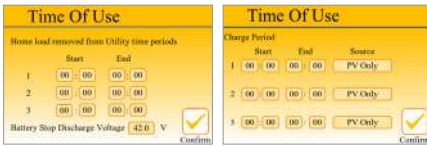

Battery settings

Here users can select different battery types, including Solax for Solax lithium batteries, Cyclone for GSL lithium batteries, Volta for GenixGreen lithium batteries, AGM for lead-acid batteries, FLD for flooded (lead-acid) batteries, TBL for ultra-capacity lead-acid batteries, and USER for user-defined options.

For charging the battery, there are options to choose from: "PV Only" allows only PV charging. "PV Then Utility" prioritizes PV charging and supplements with grid charging when needed. "PV+Utility" allows for both PV and grid charging.

The maximum discharge current of the battery in the range of (0-120A). The maximum charging current of the battery in the range of (0-120A), and the minimum discharge voltage of the battery is in the range of (40-47v).



- Battery settings for Pakistan

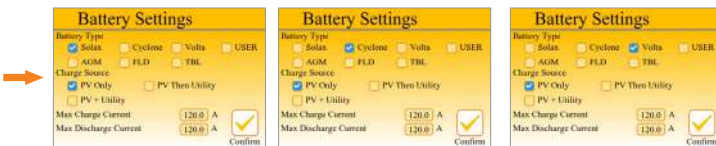

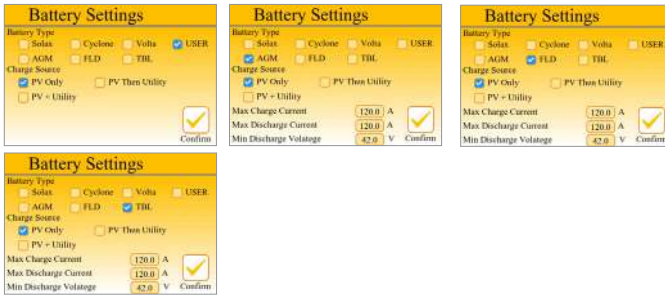

- Battery settings for other countries



When "USER" is selected, there will be an interface for further settings:



Grid export

Here users can choose between feeding excess PV power into the grid or limiting it. Selecting "No Export" disallows feeding power into the grid, while selecting "Export" allows for it and enables users to set the percentage of power to be fed in as needed. Setting "Max utility charge current" means setting the current that can be taken from the power grid when the battery is charged.



About

Here you can see some basic information of the inverter and battery.



Smart load

The generator port has three options:

- None: No device is connected to the generator port;
- Load: The generator port is connected to a load;

Settings options:

- » Smart Load Battery Off Voltage: When the voltage is below the minimum value, the battery will no longer supply power to the smart load;
- » Smart Load Battery On Voltage: When the voltage returns to normal, the battery will supply power to the smart load again.)

- Generator: The generator port is connected to the generator.

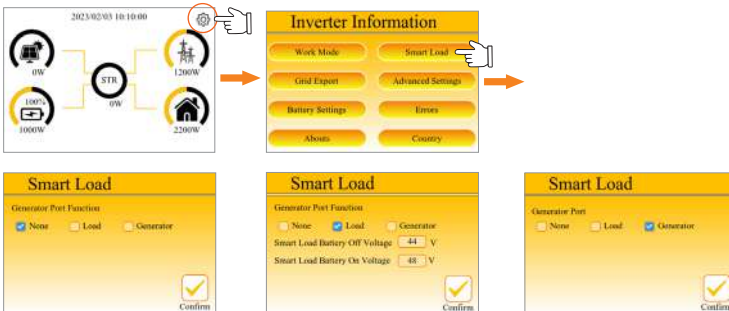

Advanced settings

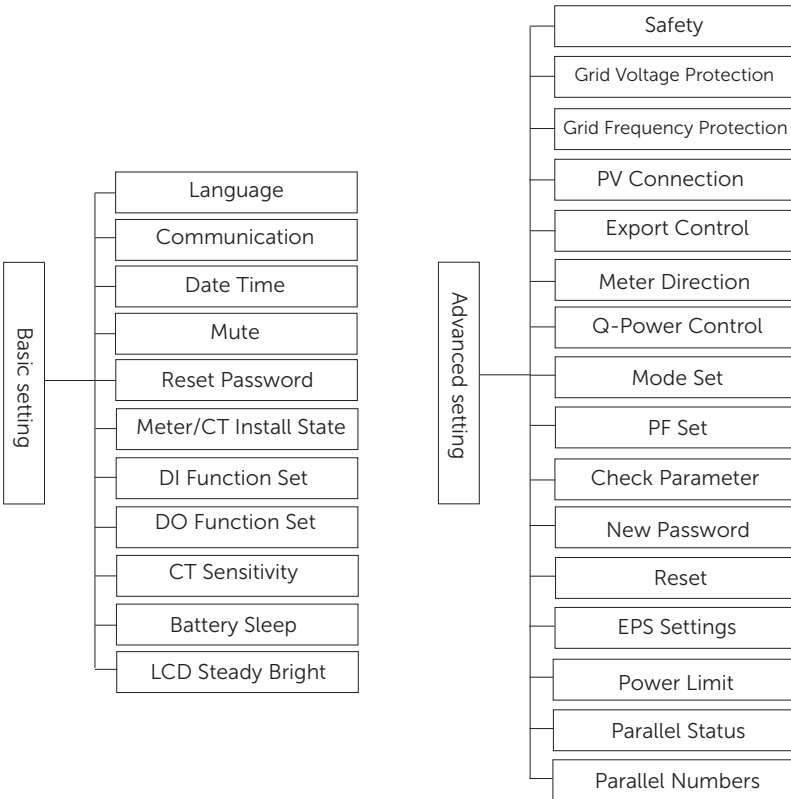

The "Basic" and "Advanced" buttons will appear if a password with advanced permission from the installer is used. The initial password for entering the basic settings is 0000, and the initial password for entering the advanced settings is 2014.

All "Basic", "Advanced", and "Super" buttons will appear if a password with factory permission is used. Please contact your installer or factory for factory password.

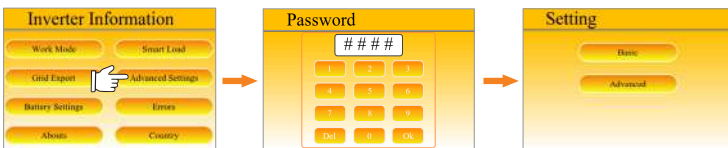

- **Basic settings**

Basic settings include user-level functional settings such as date time, communication, language, DI/DO functionality and other configuration options.



- **Advanced settings**

Advanced setting is generally customization and resetting for installers and focus on threshold values, including settings for grid protection, factory reset, clearing history record and other configuration options.

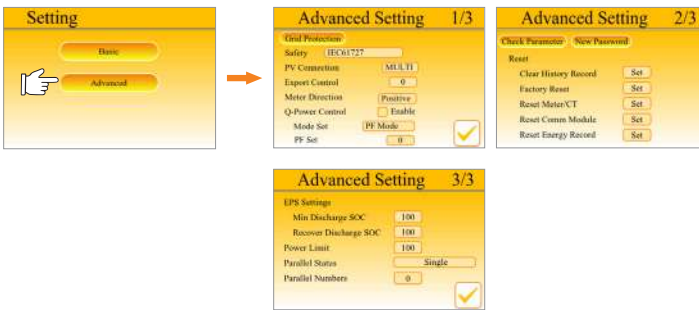

» **Grid protection**

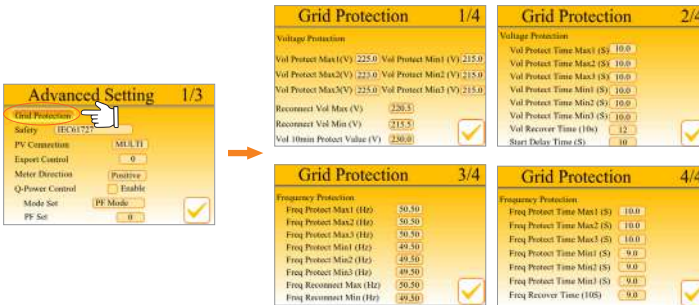

» **Check Parameter**



» New Password

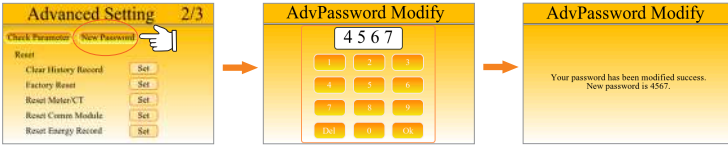

Errors

Here you can view the current faults and the historical faults. There are a total of five pages with a total of 20 records.



Country

Here you can select the country. Please note that only when "Pakistan" is selected here will Pakistan's 4 modes be displayed in "Work Mode" and the "Basic Settings" interface will be different accordingly.

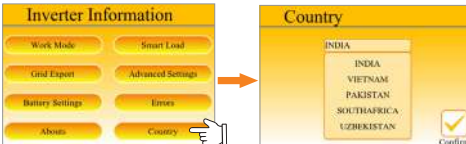

11 Operation on SolaX App and Web

11.1 Introduction of SolaXCloud

SolaxCloud is an intelligent management platform for home energy, which integrates energy efficiency monitoring, device management, data security communication and other integrated capabilities. While managing your home energy device, it helps you optimize the efficiency of electricity consumption, improve the revenue of power generation, and meet the unknown energy challenges.

11.2 Operation Guide on SolaXCloud App

11.2.1 Downloading and installing App

Select and scan the QR code below to download SolaxCloud App. You can also find the QR codes at the top left of the login page of www.solaxcloud.com or on the user manual of Pocket module. In addition, you can search with the key word "SolaxCloud" in Apple Store or Google Play to download it.



Figure 11-1 QR code

Please check the online App guide, Wifi connection guide or Setup tutorial video on the SolaXCloud App for relevant operation.

11.3 Operation Guide on SolaXCloud Web

Open a browser and enter www.solaxcloud.com to complete registration, login, add site and other related operations according to the guidelines of user guide.

12 Troubleshooting and Maintenance

12.1 Troubleshooting

This section contains information and procedures for resolving possible problems with the inverter, and provides the troubleshooting tips to identify and solve most problems that may occur. Please check the warning or fault information on the system control panel or on the App and read the suggested solutions below when error occurs. Contact SolaX Customer Service for further assistance. Please be prepared to describe the details of your system installation and provide the model and serial number of the inverter.

Error Type	Fault	Descriptions and Diagnosis
INSTALL	ISO_FAIL	Insulation impedance detection failed. <ul style="list-style-type: none"> Check whether the wire insulation is intact.
INSTALL	NO_PWR_METER	Electricity meter has no power. <ul style="list-style-type: none"> Check the status of the meter.
INSTALL	REMOTE_TURN_OFF	Remote shutdown <ul style="list-style-type: none"> Restart the inverter.
INSTALL	FREQ_CFG_UNMATCH	Frequency configuration mismatch <ul style="list-style-type: none"> Check whether the frequency is within the correct range.
INSTALL	ARC_FAIL	Arc fault <ul style="list-style-type: none"> Wait for a while to see if it returns to normal.
INSTALL	EPS_OVERLOAD_105PER	1.05 times overload <ul style="list-style-type: none"> Turn off high-power load.
INSTALL	EPS_OVERLOAD_125PER	1.25 times overload <ul style="list-style-type: none"> Turn off high-power load.
INSTALL	EPS_OVERLOAD_150PER	1.5 times overload <ul style="list-style-type: none"> Turn off high-power load.
INSTALL	EPS_OVERLOAD_LOCK	Overload self-locking <ul style="list-style-type: none"> Turn off high-power load, PV, battery and power grid, and restart inverter.
INSTALL	PV_CONN_CFG_ERROR	PV connection configuration error. <ul style="list-style-type: none"> Turn off PV, battery and power grid, restart inverter, and confirm whether PV connection is correct.
INSTALL	STARTUP_CONDITION_FAILL	Startup state failed. <ul style="list-style-type: none"> Wait for a while to see if it returns to normal.
INSTALL	BUCKBST_CFG_MODE_ERR	BUCKBST configuration mode error. <ul style="list-style-type: none"> Check whether the configuration mode of BUCKBST is correct.
PV	PV_01_REVERSE	PV1 reverse connection <ul style="list-style-type: none"> Turn off PV, battery and power grid, restart inverter, and check the connection status of positive and negative poles of PV1.
PV	PV_02_REVERSE	PV2 reverse connection <ul style="list-style-type: none"> Turn off PV, battery and power grid, restart inverter, and check the connection status of positive and negative poles of PV2.
PV	PV_01_VOLT_HIGH	PV1 Voltage is too high <ul style="list-style-type: none"> Check the output voltage of PV1.

Error Type	Fault	Descriptions and Diagnosis
PV	PV_02_VOLT_HIGH	PV2 Voltage is too high <ul style="list-style-type: none"> Check the output voltage of PV2
BAT	BAT_TYPR_CFG_ERR	Battery type configuration error <ul style="list-style-type: none"> Turn off PV, battery and power grid, restart inverter, and confirm whether the battery type is correct.
BAT	BATT_VOLT_HIGH	Battery voltage is too high <ul style="list-style-type: none"> Check whether the battery output voltage is within the normal range.
BAT	BAT_BMS_CELL_FAULT	BMS battery failure <ul style="list-style-type: none"> Please contact the battery supplier.
BAT	BAT_BMS_COMM_FAULT	BMS communication failure <ul style="list-style-type: none"> Check whether the communication between battery and inverter is normal.
BAT	BAT_SOC_LOW	Low battery SOC <ul style="list-style-type: none"> Please charge the battery in time.
BAT	BAT_CURR_HIGH	High battery current <ul style="list-style-type: none"> The load is too high, please reduce it appropriately.
GRID	GRID_LOSS	Power grid loss <ul style="list-style-type: none"> Check whether the battery input voltage is within the normal working range.
GRID	GRID_OVP1	The grid voltage exceeds the allowable value 1 <ul style="list-style-type: none"> Check whether the grid voltage is within the normal working range.
GRID	GRID_OVP2	The grid voltage exceeds the allowable value 2 <ul style="list-style-type: none"> Check whether the grid voltage is within the normal working range.
GRID	GRID_UVP1	The grid voltage is lower than the allowable value 1. <ul style="list-style-type: none"> Check whether the grid voltage is within the normal working range.
GRID	GRID_UVP2	The grid voltage is lower than the allowable value 2. <ul style="list-style-type: none"> Check whether the grid voltage is within the normal working range.
GRID	GRID_OFFP1	Power grid frequency exceeds the allowable value 1. <ul style="list-style-type: none"> Check whether the grid frequency is within the normal working range.
GRID	GRID_OFFP2	Power grid frequency exceeds the allowable value 2 <ul style="list-style-type: none"> Check whether the grid frequency is within the normal working range.
GRID	GRID_UFP1	The power grid frequency is lower than the allowable value 1. <ul style="list-style-type: none"> Check whether the grid frequency is within the normal working range.
GRID	GRID_UFP2	The power grid frequency is lower than the allowable value 2. <ul style="list-style-type: none"> Check whether the grid frequency is within the normal working range.
INV	BST01_SW_OCP	BST1 software overcurrent <ul style="list-style-type: none"> Wait for a while to see if it returns to normal.
INV	BST02_SW_OCP	BST2 software overcurrent <ul style="list-style-type: none"> Wait for a while to see if it returns to normal.
INV	BST01_HW_OCP	BST1 hardware overcurrent <ul style="list-style-type: none"> Wait for a while to see if it returns to normal.

Error Type	Fault	Descriptions and Diagnosis
INV	BST02_HW_OCP	BST2 hardware overcurrent <ul style="list-style-type: none"> • Wait for a while to see if it returns to normal.
INV	BST_OVER_PWR	BST overpower <ul style="list-style-type: none"> • Wait for a while to see if it returns to normal.
INV	BUCKBST_HW_OCP	BuckBst hardware overcurrent <ul style="list-style-type: none"> • Wait for a while to see if it returns to normal.
INV	BUCKBST_SW_OCP	BuckBst software overcurrent <ul style="list-style-type: none"> • Wait for a while to see if it returns to normal.
INV	BUCKBST_SW_OVP	BuckBst software overvoltage <ul style="list-style-type: none"> • Wait for a while to see if it returns to normal.
INV	BUCKBST_SW_UVP	BuckBst software undervoltage <ul style="list-style-type: none"> • Wait for a while to see if it returns to normal.
INV	LLC_HW_OCP	Llc hardware overcurrent <ul style="list-style-type: none"> • Wait for a while to see if it returns to normal.
INV	LLC_START_FAIL	Llc startup failed. <ul style="list-style-type: none"> • Wait for a while to see if it returns to normal.
INV	BUCKBST_START_FAIL	BuckBst startup failed. <ul style="list-style-type: none"> • Wait for a while to see if it returns to normal.
INV	DCBUS_INIT_CHK_FAIL	DCBUS initialization detection failed. <ul style="list-style-type: none"> • Turn off PV, battery and power grid, and restart inverter.
INV	DCBUS_HW_OVP	DCBUS hardware overvoltage <ul style="list-style-type: none"> • Wait for a while to see if it returns to normal.
INV	DCBUS_SW_OVP	DCBUS software overvoltage <ul style="list-style-type: none"> • Wait for a while to see if it returns to normal.
INV	DCBUS_SW_UVP	DCBUS software overvoltage <ul style="list-style-type: none"> • Wait for a while to see if it returns to normal.
INV	DCBUS_SHORT	DCBUS short circuit <ul style="list-style-type: none"> • Turn off PV, battery and power grid, and restart inverter.
INV	DCBUS_INV_SS_FAIL	DCBUS inverter soft start failed. <ul style="list-style-type: none"> • Wait for a while to see if it returns to normal.
INV	DCBUS_BST_SS_FAIL	DCBUS BST soft start failed. <ul style="list-style-type: none"> • Wait for a while to see if it returns to normal.
INV	DCBUS_BUCKBST_SS_FAIL	DCBUS BUCKBST soft start failed. <ul style="list-style-type: none"> • Wait for a while to see if it returns to normal.
INV	INV_PLL_FAIL	Inverter phase-locked failure <ul style="list-style-type: none"> • Wait for a while to see if it returns to normal.

Error Type	Fault	Descriptions and Diagnosis
INV	INV_RLY_FLT	Inverter relay fault <ul style="list-style-type: none"> • Wait for a while to see if it returns to normal.
INV	INV_RLY_ON_FAIL	Pull-in fault of inverter relay <ul style="list-style-type: none"> • Wait for a while to see if it returns to normal.
INV	INV_EPS_RLY_FAULT	EPS end relay failure <ul style="list-style-type: none"> • Wait for a while to see if it returns to normal.
INV	INV_SS_ACVOLT_FAIL	Soft start AC voltage failed. <ul style="list-style-type: none"> • Wait for a while to see if it returns to normal.
INV	INV_SW_OCP	Inverter software overcurrent <ul style="list-style-type: none"> • Wait for a while to see if it returns to normal.
INV	INV_HW_WAVE_OCP	Inverter hardware half-wave overcurrent <ul style="list-style-type: none"> • Wait for a while to see if it returns to normal.
INV	INV_HW_OCP	Inverter hardware overcurrent <ul style="list-style-type: none"> • Wait for a while to see if it returns to normal.
INV	INV_GFCI_CT_FAIL	CT fault <ul style="list-style-type: none"> • Wait for a while to see if it returns to normal. Check whether CT works properly.
INV	INV_GFCI_PROT	GFCI fault <ul style="list-style-type: none"> • Wait for a while to see if it returns to normal.
INV	INV_FREQT_OCP	Inverter frequent overcurrent alarm <ul style="list-style-type: none"> • Wait for a while to see if it returns to normal. Check whether the inverter current works in the normal range.
INV	INV_SW_OVP	Inverter software overvoltage <ul style="list-style-type: none"> • Please shut down and restart.
VER	TYPE_MODEL_ERR	Model configuration error <ul style="list-style-type: none"> • Turn off PV, battery and power grid, and restart inverter. Check whether the inverter model is configured correctly.
BMS	BMS_CELL_OVER_FAULT	Overvoltage fault of cell. <ul style="list-style-type: none"> • Wait for fault recovery, restart the battery and contact after-sales personnel.
BMS	BMS_CELL_LOW_FAULT	Undervoltage fault of cell. <ul style="list-style-type: none"> • Recharge the battery..
BMS	BMS_CELL_DIFF_FAULT	Excessive voltage difference fault of cell. <ul style="list-style-type: none"> • Ensure that the battery works in the normal voltage range.
BMS	BMS_HVB_OVER_FAULT	Overvoltage fault of total voltage. <ul style="list-style-type: none"> • Wait for fault recovery, restart the battery and contact after-sales personnel.
BMS	BMS_HVB_LOW_FAULT	Undervoltage fault of total voltage. <ul style="list-style-type: none"> • Recharge the battery.
BMS	BMS_TEMP_OVER_FAULT	High temperature fault. <ul style="list-style-type: none"> • Stop using the battery and wait for the temperature to recover.

Error Type	Fault	Descriptions and Diagnosis
BMS	BMS_SELF_CHECK_FAULT	Self-test fault. <ul style="list-style-type: none"> Check the battery failure and contact the after-sales personnel.
BMS	BMS_POS_RLY_ADH_FAULT	Main positive relay sticking fault. <ul style="list-style-type: none"> Please contact the after-sales personnel.
BMS	BMS_POS_RLY_OPEN_FAULT	Main positive relay open circuit fault. <ul style="list-style-type: none"> Please contact the after-sales personnel.
BMS	BMS_NEG_RLY_ADH_FAULT	Main negative relay sticking fault. <ul style="list-style-type: none"> Please contact the after-sales personnel.
BMS	BMS_NEG_RLY_OPEN_FAULT	Main negative relay open circuit fault. <ul style="list-style-type: none"> Please contact the after-sales personnel.
BMS	BMS_PRECHG_FAIL_FAULT	Pre-charge failure fault. <ul style="list-style-type: none"> Reset the battery. If this fault is reported many times, please contact after-sales personnel.
BMS	BMS_CELL_SAMPLING_FAULT	Cell sampling fault. <ul style="list-style-type: none"> Please contact the after-sales personnel..
BMS	BMS_TEMP_SAMPLE_FAULT	Temperature sampling fault. <ul style="list-style-type: none"> Please contact the after-sales personnel.
BMS	BMS_SYS_FAULT	System fault. <ul style="list-style-type: none"> Please contact the after-sales personnel.
BMS	BMS_DSG_OVER_FAULT	Over-discharge current fault. <ul style="list-style-type: none"> Stop using the battery and wait for it to recover or restart the battery. If this fault is reported many times, please contact the after-sales personnel..
BMS	BMS_CHG_OVER_FAULT	Over-charge current fault. <ul style="list-style-type: none"> Ensure that the battery works in the normal voltage range.
BMS	BMS_AFE_COM_FAULT	AFE communication fault. <ul style="list-style-type: none"> Please contact the after-sales personnel.
BMS	BMS_INV_COM_FAULT	External network communication fault. <ul style="list-style-type: none"> Check the communication line between the battery and the inverter. If this fault still occurs after reinserting the line, please contact the after-sales personnel.
BMS	BMS_MID_COM_FAULT	Intermediate network communication fault. <ul style="list-style-type: none"> Check the communication line between the batteries. If this fault still occurs after reinserting the line, please contact the after-sales personnel.
BMS	BMS_VOLT_SENSOR_FAULT	Voltage sensor fault. <ul style="list-style-type: none"> Please contact the after-sales personnel.
BMS	BMS_ID_REPET_FAULT	ID duplication fault. <ul style="list-style-type: none"> Check if the system connections are correct and follow the initial installation steps to perform the startup operation again.
BMS	BMS_TEMP_LOW_FAULT	Low temperature fault. <ul style="list-style-type: none"> Wait for fault recovery, restart the battery and contact after-sales personnel.
BMS	BMS_CURR_SENSOR_FAULT	Current sensor fault. <ul style="list-style-type: none"> Please contact the after-sales personnel.

Error Type	Fault	Descriptions and Diagnosis
BMS	BMS_LINE_FAULT	Power line open circuit fault. <ul style="list-style-type: none"> Check whether the power line is connected properly and restart the battery.
BMS	BMS_FLASH_FAULT	Flash fault. <ul style="list-style-type: none"> Please contact the after-sales personnel.
BMS	BMS_AFE_PROTECT_FAULT	AFE self-protection fault. <ul style="list-style-type: none"> Please contact the after-sales personnel.
BMS	BMS_CHG_REQ_FAULT	Charging request fault. <ul style="list-style-type: none"> Check if the inverter is correctly supplying power to the battery.
BMS	BMS_INS_FAULT	Insulation fault. <ul style="list-style-type: none"> Please contact the after-sales personnel.
INV	BAT_VOLT_OUT_RANGE	Battery voltage overrun <ul style="list-style-type: none"> Ensure that the battery works in the normal voltage range.
INV	PV_VOLT_OUT_RANGE	Battery voltage overrun <ul style="list-style-type: none"> Ensure that PV works in the normal voltage range.
INV	BAT_SOC_LOW_ON_GRID	Low soc of grid-connected battery <ul style="list-style-type: none"> Stop discharging and start charging.
INV	BAT_SOC_LOW_OFF_GRID	Low soc of off-grid battery <ul style="list-style-type: none"> Stop discharging and start charging.
INV	INV_PWR_DRT	Inverter power derating <ul style="list-style-type: none"> Ensure that the inverter power is within the normal range.
INV	BAT_CHRG_PWR_DRT	Battery charging power derating <ul style="list-style-type: none"> Ensure that the battery charging power is within the normal range.
INV	BAT_DISCHRG_PWR_DRT	Battery discharge power derating <ul style="list-style-type: none"> Ensure that the battery discharge power is within the normal range.
INV	BAT_FLOATING_CHRG	Battery floating charge <ul style="list-style-type: none"> Check battery voltage.
INV	BAT_REPLENISH_CHRG	Battery recharge <ul style="list-style-type: none"> Check the battery voltage and replenish the power in time.
INV	BAT_PWR_IN_CFG_MODE	Battery power configuration mode <ul style="list-style-type: none"> Make sure that the battery works correctly.
INV	BST_IN_CVS_MODE	BST constant voltage source mode. <ul style="list-style-type: none"> BST operates in constant voltage source mode.
INV	PV_PWR_DRT_INV_PWR_LMT	Inverter power limit <ul style="list-style-type: none"> Ensure that the inverter output power is within the normal range.
INV	PV_PWR_DRT_ZERO_EXPORT	Anti-reflux. <ul style="list-style-type: none"> Ensure that it is in an anti-reflux state.
INV	PV_PWR_DRT_CHRG_PWR_LMT	Charging power limit. <ul style="list-style-type: none"> Ensure that the charging power is within the normal range.

Error Type	Fault	Descriptions and Diagnosis
INV	PV_PWR_DRT_CURR_LMT	Current limiting <ul style="list-style-type: none"> • Ensure that the current works within the normal range.
COM	INTER_FAN_FAIL	Internal fan failed. <ul style="list-style-type: none"> • Check whether there is any foreign matter inside the fan.
INSTALL	EXTERN_FAN_FAIL	External fan failure <ul style="list-style-type: none"> • Please check if the external fan is damaged or blocked..
INSTALL	DSP_UPDATE_FAIL	DSP upgrade failure <ul style="list-style-type: none"> • Please contact after-sales for assistance with software up grade.
INSTALL	ARM_UPDATE_FAIL	ARM upgrade failure <ul style="list-style-type: none"> • Please contact after-sales for assistance with software upgrade.
INSTALL	SMCU_UPDATE_FAIL	SMCU upgrade failure <ul style="list-style-type: none"> • Please contact after-sales for assistance with software upgrade.
INSTALL	NO_METER	Meter loss <ul style="list-style-type: none"> • Please check if the meter is connected or if the meter communication line works normally.
INSTALL	NO_CT	CT loss <ul style="list-style-type: none"> • Please check if the CT is connected.
INSTALL	NO_NTC	NTC loss <ul style="list-style-type: none"> • Please check if the NTC is connected correctly.
INSTALL	BMS_LOST	Communication loss between inverter and battery management system equipment. <ul style="list-style-type: none"> • Please check the connection status between the BMS device and the inverter.

Please contact our customer service for further assistance. And please be prepared to describe the details of your system installation and provide the inverter serial number and the registration number.

Please check the following list to ensure that the inverter is in the correct operation state if the information panel does not display the fault light.

- Is the inverter located in a clean, dry, and well-ventilated place?
- Is the DC input circuit breaker open?
- Is the specification and length of the cable adequate?
- Are the input and output connections and wiring in good condition?
- Is the configuration set correctly for your particular installation?

12.2 Maintenance

Regular maintenance is required for the inverter. The table below lists the operational maintenance for expressing the optimum device performance. More frequent maintenance service is needed in the worse work environment. Please make records of the maintenance.



- Only qualified person can perform the maintenance for the inverter.
- Only use the spare parts and accessories approved by SolaX for maintenance.

Maintenance routines

Item	Check notes	Maintenance interval
Safety check	<ul style="list-style-type: none"> • Check the items mentioned in section 1 "Safety" • The safety check shall be performed by manufacturer's qualified person who has adequate training, knowledge, and practical experience. 	Every 12 months
Indicators	<ul style="list-style-type: none"> • Check if the indicators of the inverter are in normal state. • Check if the display of the inverter (if it has screen) is normal. 	Every 6 months
Fans	<ul style="list-style-type: none"> • Check if the cooling fans on the bottom of the inverter are covered by dirt or if there is abnormal sound. • Clean the cooling fans with a soft dry cloth or brush or replace it if necessary. 	Every 6-12 months
Electrical connection	<ul style="list-style-type: none"> • Ensure that all cables are firmly connected. • Check the integrity of the cables, ensuring that there are no scratches on the parts touching the metallic surface. • Verify that the sealing caps on idle terminals are and not falling off. 	Every 6-12 months
Grounding reliability	<ul style="list-style-type: none"> • Check whether the ground terminal and ground cable are securely connected. Use Ground Resistance Tester to test the ground resistance from inverter enclosure to PE bar in the power distribution box. 	Every 6-12 months
Heat sink	<ul style="list-style-type: none"> • Check whether the heat sink is covered with foreign objects. 	Every 6-12 months

Item	Check notes	Maintenance interval
General status of inverter	<ul style="list-style-type: none">• Check if there is any damage on the inverter.• Check if there is any abnormal sound when the inverter is running.	Every 6 months

12.3 Firmware Upgrade

12.3.1 Upgrade preparation

- a. Check the inverter version and prepare a U disk (USB 2.0/3.0) and personal computer before upgrading.
- b. Contact our service support to get the update files ("*.bin" and "*.txt" file), and store the two files in the root path of the U disk. Files:
X1HybridLV_3_6kW_lap.txt
X1HybridLV_3_6kW_***.bin



- Please make sure that the size of the U disk is smaller than 32GB, and the format is FAT16 or FAT32.
- The bin name listed in the "*.txt" file must be same as the "*.bin" name.

12.3.2 Upgrade steps

- Step 1:** Plug the U disk into the upgrading port below: If the Wi-Fi dongle is connected to the port, please remove the dongle first.
- Step 2:** After the U disk is plugged in, the system will start upgrading, and the three indicator lights will flash in turns. (Operating indicator: green; battery indicator: blue; Error indicator: Red). Wait approximately 10-15 seconds.
- Step 3:** After the LCD screen turns off, the buzzer will make a beep sound, and then the screen and three indicator lights will light up again and flash in turns.
- Step 4:** If the three indicators light up at the same time, it means that the upgrade has been successful. If only the red light is on, it means that the upgrade has failed. If the upgrade fails, please contact our after-sales support.

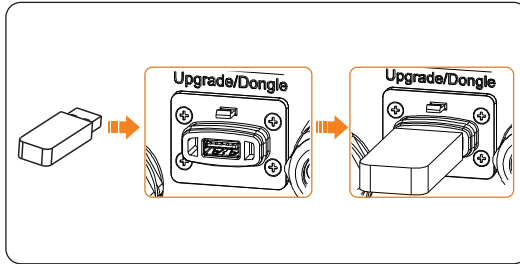

Figure 12-2 Plug in the U disk

NOTICE!

- The USB disk can be plugged in when the inverter is in normal status.
- After the upgrade is completed, the current state of the indicator will be maintained for 1 minute, and the inverter will be automatically switched on.

13 Decommissioning

13.1 Power off

- a. Turn off the system by **System ON/OFF** on LCD screen.
- b. Press the Button on the inverter to shut down the system;

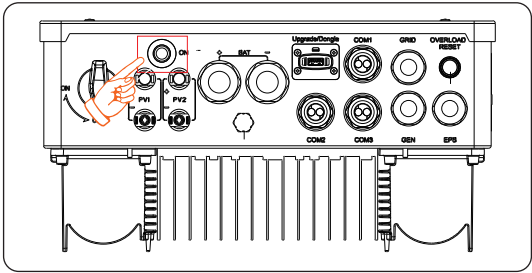

Figure 13-1 Pressing the button

- c. Turn off the AC and EPS breakers between the inverter and the power grid;
- d. Turn off the DC switch on the inverter.

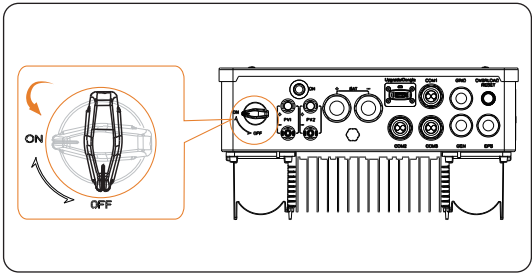

Figure 13-2 Turning off DC switch

WARNING!

- Wait for at least 5 minutes to fully discharge the capacitors inside the inverter system.
- After the inverter powers off, there will still be the remaining electricity and heat which may cause electric shocks and body burns. Please wear personal protective equipment (PPE) and begin servicing the inverter five minutes after power off.

13.2 Disassembling the Inverter



- When disassembling the inverter, strictly follow the steps as below.
- Only use measuring devices with a DC input voltage range of 600 V or higher.

Step 1: Use a current clamp to ensure there is no current present in the PV cables.

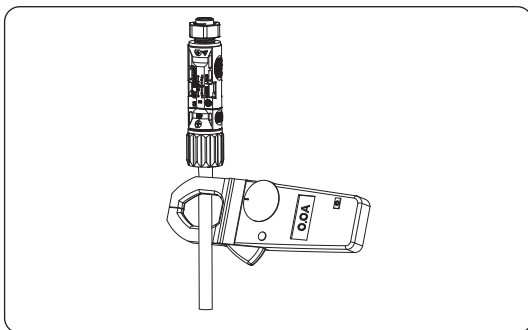

Figure 13-3 Measuring the current

Step 2: Use the disassembling tool for PV terminal to disassemble the PV cables. Then remove the PV cables, and slightly pull out the cables.

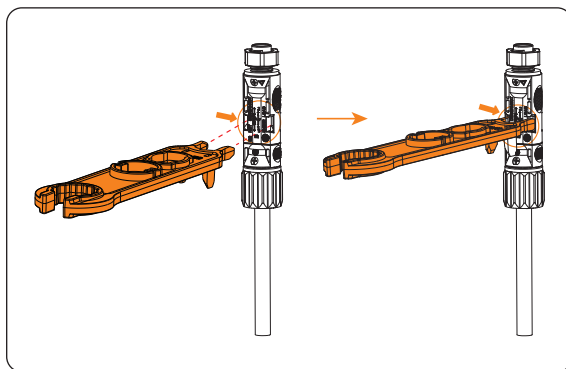

Figure 13-4 Disassembling the PV cables

Step 3: Remove the lower cover of the inverter, measure whether there is AC voltage. If not, remove the cables from Grid, GEN and EPS port.

Step 4: Remove the Communication cable.

Step 5: Remove the Meter/CT cable.

Step 6: Remove the PE cable.

Step 7: Remove the Dongle.

Step 8: Close the lower cover of the inverter.

Step 9: Unscrew the screws of fastening the wall mounting bracket and remove the wall mounting bracket.

Step 10: Remove the inverter.

13.3 Packing the Inverter

- Load the inverter into the original packing material if possible.
- If the original packing material is not available, use the packing material which meets the following requirements:
 - » Suitable for the weight of product
 - » Easy to carry
 - » Be capable of being closed completely

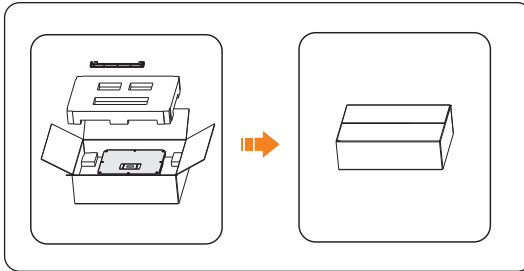

Figure 13-5 Packing the inverter

13.4 Disposing of the Inverter

Please dispose of the inverters or accessories in accordance with the electronic waste disposal regulations applicable at the installation site.

14 Technical Data

14.1 DC Input

Model	X1-HYB-3.0-LV	X1-HYB-3.7-LV	X1-HYB-4.0-LV	X1-HYB-4.6-LV	X1-HYB-5.0-LV	X1-HYB-6.0-LV
Max. PV array power [Wp]	4500	5500	6000	6900	7500	9000
Max. PV input voltage [V]	550					
Start output voltage[V]	110					
Nominal input voltage [V]	360					
MPPT voltage range[V]	80 ~ 520					
No. of MPPT/Strings per MPPT	2(1/1)					
Max. input current[A]	16/16					
Max. short circuit current[A]	20/20					
MPPT Voltage Range[V] (Full Load)	115~440	140~440	150~440	175~440	190~440	230~440

14.2 AC Input&Output

Model	X1-HYB-3.0-LV	X1-HYB-3.7-LV	X1-HYB-4.0-LV	X1-HYB-4.6-LV	X1-HYB-5.0-LV	X1-HYB-6.0-LV
Nominal AC Output Current[A]	13	16	17.4	20	21.7	26.1
Nominal AC output power[W]	3000	3680	4000	4600	5000	6000
Max. AC output apparent power[VA]	3300	3680	4400	4600 (Germany 4600)	5000	6000
Max. AC output current [A]	15	16	20	20.9 (Germany 20)	22.7	27.3
Max. AC input apparent power [VA]	6000	7360	8000	9200	9200	9200
Max. AC input current [A]	26.1	32	34.8	40	40	40
Nominal voltage [V], frequency [Hz]	220/230/240, 50/60					
Displacement power factor	0.8 leading ~ 0.8 lagging					
THDi (rated power) [%]	<3					
AC Connection	L/N/PE					
DC Disconnection Switch	Optional					

14.3 EPS Output

Model	X1-HYB-3.0-LV	X1-HYB-3.7-LV	X1-HYB-4.0-LV	X1-HYB-4.6-LV	X1-HYB-5.0-LV	X1-HYB-6.0-LV
Nominal output power [W]	3000	3680	4000	4600	5000	6000
Peak apparent power[VA] ¹	2 times the rated power, 10s					
Nominal Output Current[A]	13	16	17.4	20	21.7	26.1
Nominal voltage [V], frequency [Hz]	230, 50/60					
Switch Time[ms]	<10					

14.4 Battery Data

Model	X1-HYB-3.0-LV	X1-HYB-3.7-LV	X1-HYB-4.0-LV	X1-HYB-4.6-LV	X1-HYB-5.0-LV	X1-HYB-6.0-LV
Battery type	Lithium/Lead-Acid					
Battery voltage range [V]	40~60					
Nominal Battery Voltage[V]	48					
Max. Charging Voltage[V]	≤60 (Adjustable)					
Max. Charging/Discharging Current[A]	75			120		
Charging Strategy for Li-Ion Battery	Self-adaption to BMS					
Charging Strategy for Lead-Acid Battery	3 stages curve					
Temperature Sensor	Optional					

14.5 System Data

Model	X1-HYB-3.0-LV	X1-HYB-3.7-LV	X1-HYB-4.0-LV	X1-HYB-4.6-LV	X1-HYB-5.0-LV	X1-HYB-6.0-LV
MPPT Efficiency	>99.9%					
Max. efficiency [%]	97.6					
Euro. efficiency [%]	97.0					
Battery charge/discharge efficiency [%] ²	96.0/95.0					

14.6 Protection Device

Model	X1-HYB-3.0-LV	X1-HYB-3.7-LV	X1-HYB-4.0-LV	X1-HYB-4.6-LV	X1-HYB-5.0-LV	X1-HYB-6.0-LV
Anti-Islanding Protection	Yes					
PV String Input Reverse Polarity Protection	Yes					
Insulation Resistor Detection	Yes					
Residual Current Monitoring Unit	Yes					
Output Over Current Protection	Yes					
Output Short Protection	Yes					
Output Over Voltage Protection	Yes					
Surge Protection	AC Type III/DC Type III					
Battery Terminal Temp Protection	Yes					

14.7 Power Consumption & Environment Limit

Model	X1-HYB-3.0-LV	X1-HYB-3.7-LV	X1-HYB-4.0-LV	X1-HYB-4.6-LV	X1-HYB-5.0-LV	X1-HYB-6.0-LV
Self Consumption(night) [W]	Standby < 40, Shutdown < 10					
Degree of protection	IP65					
Operating temperature range[°C]	-25 ~ +60 (derating above +45)					
Relative humidity [%]	0 ~ 100 (condensing)					
Max. operation altitude [m]	<3000					
Storage Temperature[°C]	-25 ~ +70					
Noise Emission(typical)[dB]	<39			<50		

14.8 Protection Device

Model	X1-HYB-3.0-LV	X1-HYB-3.7-LV	X1-HYB-4.0-LV	X1-HYB-4.6-LV	X1-HYB-5.0-LV	X1-HYB-6.0-LV
Dimensions(WxHxD) [mm]	397x490x201					
Net weight [kg]	16.5			17.5		
Cooling concept	Natural			Smart cooling		
Topology	Transformerless for PV Side/HF for battery Side					
HMI Interface	LED+LCD					
Communication interfaces	CAN, RS485, CT, Meter, WiFi, LAN, 4G (Optional), USB , NTC, wifi+lan, wifi+4G					

NOTICE!

- The specific gross weight is subject to the actual situation of the whole machine, which may be a little different due to the influence of the external environment.

Contact Information



UNITED KINGDOM

- Unit C-D Riversdale House, Riversdale Road, Atherstone, CV9 1FA
- +44 (0) 2476 586 998
- service.uk@solaxpower.com



TURKEY

- Fevzi Çakmak mah. aslım cd. no 88 A Karatay / Konya / Türkiye
- service.tr@solaxpower.com



USA

- 3780 Kilroy Airport Way, Suite 200, Long Beach, CA, US 90806
- +1 (408) 690 9464
- info@solaxpower.com



POLAND

- WARSAW AL. JANA P. II 27. POST
- +48 662 430 292
- service.pl@solaxpower.com



ITALY

- +39 011 19800998
- support@solaxpower.it



PAKISTAN

- service.pk@solaxpower.com



AUSTRALIA

- 21 Nicholas Dr, Dandenong South VIC 3175
- +61 1300 476 529
- service@solaxpower.com.au



GERMANY

- Am Tullnaupark 8, 90402 Nürnberg, Germany
- +49 (0) 6142 4091 664
- service.eu@solaxpower.com
- service.dach@solaxpower.com



NETHERLANDS

- Twekkeler-Es 15 7547 ST Enschede
- +31 (0) 8527 37932
- service.eu@solaxpower.com
- service.bnl@solaxpower.com



SPAIN

- +34 9373 79607
- tecnico@solaxpower.com



BRAZIL

- +55 (34) 9667 0319
- info@solaxpower.com



SOUTH AFRICA

- service.za@solaxpower.com



SolaX Power Network Technology (Zhejiang) Co., Ltd.

Add.: No. 278, Shizhu Road, Chengnan Sub-district, Tonglu County,
Hangzhou, Zhejiang, China
E-mail: info@solaxpower.com

