



Atrix Max+

User Manual

Atrix Max-16L-P

16 kWh Battery Storage System

Version: V1.0

Content

1	Safety precaution.	1
1.1	Storage and installation environment	1
1.2	Battery safety guidelines	1
1.3	Warning signs and stickers	1
1.4	Emergency handling	2
2	Product description	3
2.1	Product introduction	3
2.2	Product appearance description.	4
2.3	Battery LED description	5
3	Installation guide.	6
3.1	Installation site requirements	6
3.1.1	Environmental requirements	6
3.1.2	Physical installation requirements.	7
3.1.3	Preparation of installation tools.	9
3.1.4	Unboxing guide.	10
3.2	Installation steps	11
4	Electrical connection.	14
4.1	Grounding	14
4.2	Cable installation.	15
4.3	Guide of electrical connection	16
5	System commissioning	19
5.1	System power on.	19
5.2	System power off	19
5.3	System configuration	20
6	Maintenance and troubleshooting	22
6.1	Routine maintenance.	22
6.2	Fault checklist	23
7	Warehouse storage guidelines.	24
7.1	Packaging guidelines.	24
7.2	Storage	25
8	Dispose of used batteries.	25
9	Detailed parameter	26

1 Safety precaution

Read the manual carefully and operate in accordance with the safety precautions. Refer to local safety regulations on items not covered in this manual. Electrical installation, maintenance must be performed by professional / qualified personnel.













1.1 Storage and installation environment





- Handle the product gently, prevent from dropping
- Avoid open flame; keep away from flammables, explosives or corrosive chemicals
- Choose a cool and dry place for storage and installation
- Prevent from water or humid intrusion
- Prevent from accidental access (children and animals)
- Do not step on the product packaging
- Do not place any foreign objects on top of the battery pack
- Do not store the battery pack upside down

1.2 Battery safety guidelines

- Prevent from electrostatic discharge
- Wear insulating gloves when handling batteries.
- Do not energize auxiliary power during installation
- Check the polarity carefully before switching on the system
- Defected or damaged batteries shall not be charged or discharged

1.3 Warning signs and stickers

	Warning generic hazard		Do not mix with domestic
	Warning High voltage - Electrical shock hazard		Please recycle
	No flame		This side up
	No stepping on		User manual
	Warning High temperature		Protective earth (connector)
	Warning High Voltage Wait 5 min till fully discharged		Protective earth (general identification)

	Do not short circuit (cut off power)		Keep away from children
	Fragile		Do not get wet

1.4 Emergency handling

Wear personal protective equipment (PPE) such as goggles, a facemask, insulated gloves and boots. Evaluate the situation before taking remedial action. When it is safe to do so, disconnect the external AC or DC power connection.

Damaged or deformed battery enclosure

Risk of chemical leakage (i.e. electrolyte) and internal short-circuit.



Warning

Deformed or severely damaged battery pack can lead to the piercing of cell pouch (chemical leakage) or an internal short-circuit (thermal runaway). The damaged battery pack can release toxic gas. Keep away from it.

In case of accidental skin contact, wash the skin thoroughly with soap and seek medical advice. For eye contact, wash under running water (~15 minutes) and require immediate medical attention.

Fire hazard

If the fire is not from the battery or not spread to the battery, use FM-200 or CO₂ fire extinguisher to put out the fire.

If the battery pack catches fire, do not attempt to put out the fire and evacuate immediately.

Seek medical attention in case of inhalation of pungent and toxic fumes.

Keep damaged batteries isolated and call your local fire department, contact service for further support.

Note:

1. If a fire occurs during battery charging, disconnect the battery pack circuit breaker and cut off the power supply for charging under safe conditions.
2. If the battery string does not catch fire, extinguish the fire before the battery string catches fire.
3. If the battery pack catches fire, do not attempt to extinguish the fire. Evacuate immediately.

Water damage

Risk of electric shock and internal short-circuit. In case of splash or water spillage, when it is safe to do so, dry the product. If any part of the battery system is submerged, keep away from water.

Do not reuse the submerged battery. Contact a support service.

2 Product description

This document mainly introduces the product, installation, electrical connection, commissioning, maintenance, and troubleshooting of the Atrix Max+ energy storage system. Before installing and operating Atrix Max+, ensure that you are familiar with the product features, functions, and safety precautions provided in this document. Products can be paralleled to build a multi-module system with more capacity to satisfy the longtime energy storage demand.

2.1 Product introduction

- Atrix Max-16L-P is a lithium battery energy storage system based on the Lithium Iron Phosphate (LFP), consists of 314Ah cells (1P16S).
- Flexible configuration allow parallel of multiple batteries for longer standby time. The maximum parallel units are 32 pcs that can expand the capacity up to 512 kWh.
- The battery energy storage system can be combined with the inverter by CAN or RS485 communication. Batteries store or release electrical energy according to the requirements of the inverter management system
- Advanced battery management system (BMS) provides data acquisition, status monitoring and control to ensure the safe and reliable operation of the system.
- The system adopts an IP65 protection design to support indoor or outdoor use.

System Diagram

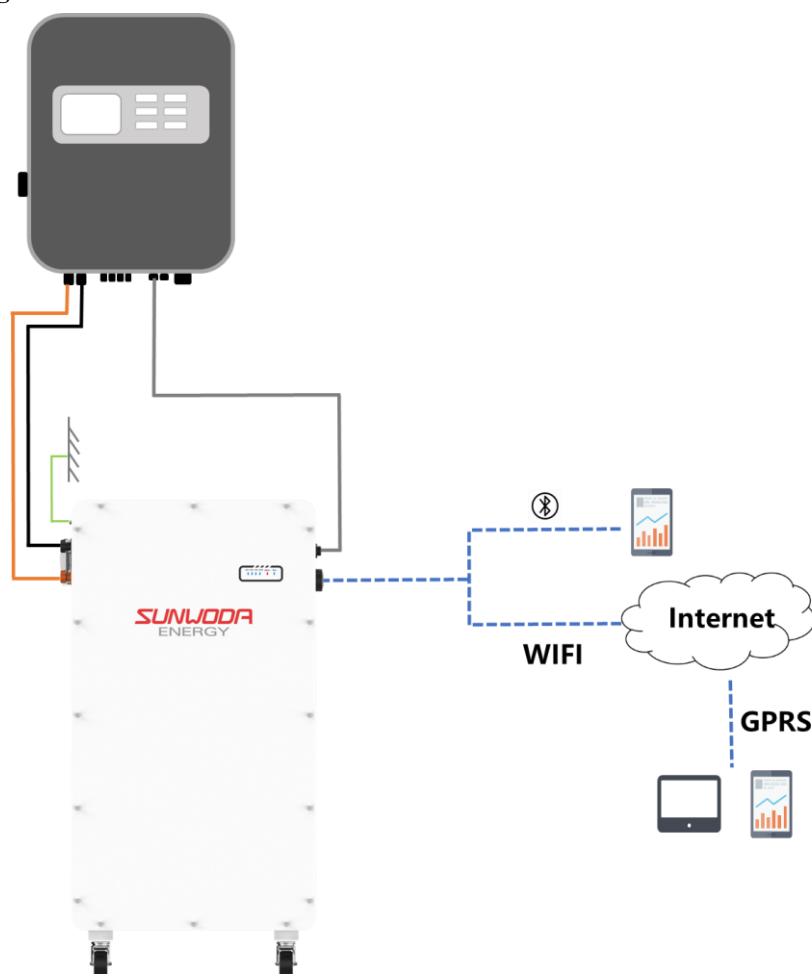

2.2 Product appearance description

① Product size chart:

The battery size diagram and effect diagram is shown in the following figure:

Size: W*D*H=500*970*265mm

Weight: 130kg

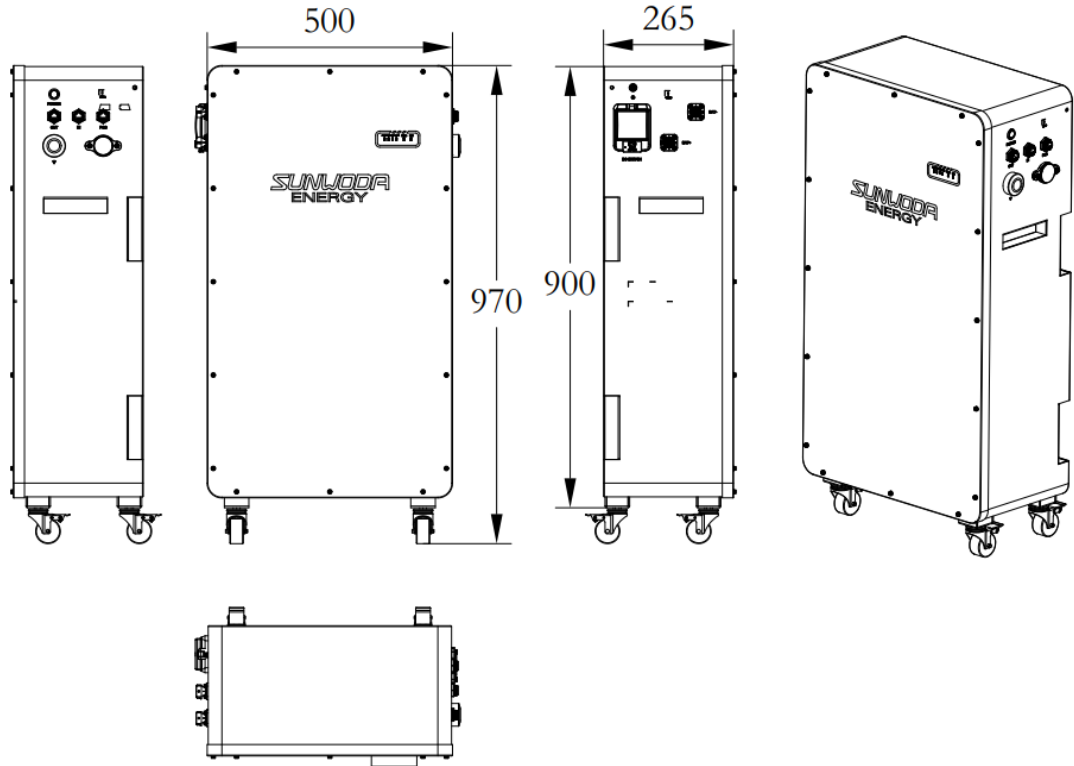

Battery dimensions



Battery module diagram

② Product interface function description:

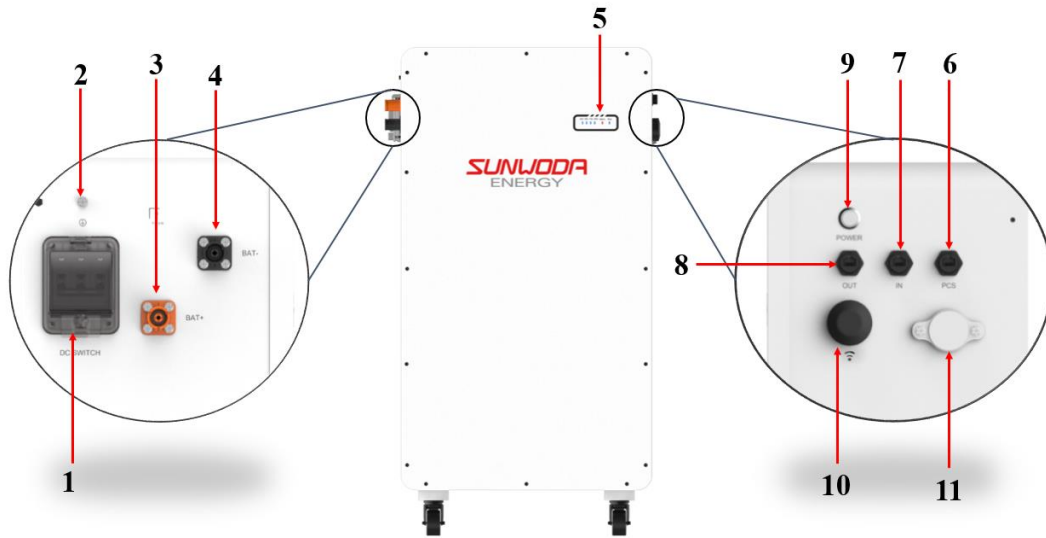

No	Item	Function	Note
1	DC Switch	Battery external DC circuit breaker switch	
2	PE	Grounding protection	
3	BAT+	Positive terminal	
4	BAT-	Negative terminal	
5	LED	Indicate the battery information	Refer to 2.3 Battery LED description
6	PCS	Communication interface with PCS	
7	IN	Parallel communication input interface	
8	OUT	Parallel communication output interface	
9	POWER	Power-on/off control button	
10	WIFI	WiFi antenna	
11	Relief Valve	Balance the air pressure inside and outside the battery module	

2.3 Battery LED description

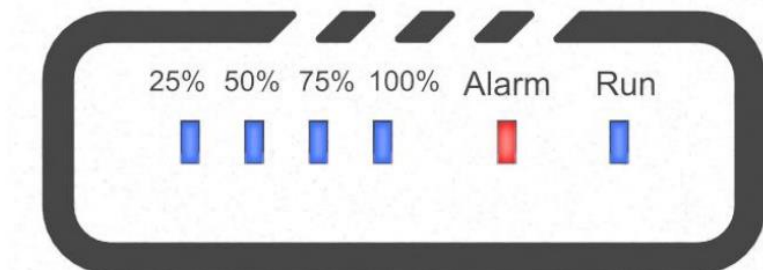

On the battery panel, 6 LED indicators indicate the current SOC, warning or operating status of the battery.

Battery status	Power LED (from low to high)	Alarm	RUN	Priority
----------------	------------------------------	-------	-----	----------

Shutdown								
Battery charging	0% -25% battery capacity	★	★	★	★		●	
	26% -50% battery capacity	●	★	★	★		●	
	51% -75% battery capacity	●	●	★	★		●	
	76% -99% battery capacity	●	●	●	★		●	
	100% battery capacity	●	●	●	●		●	
Battery discharge	0% -3% battery capacity	★					●	
	4-25% battery capacity	●					●	
	26% -50% battery capacity	●	●				●	
	51% -75% battery capacity	●	●	●			●	
	76% -99% battery capacity	●	●	●	●		●	
Protection	Battery protection					●	●	*
Malfunction	Battery failure					●		*
<p>Note:</p> <p>● indicates constant light, ★ indicates flashing, and the indicator light flashes at a frequency of 1Hz</p> <p>*Other indicator lights on indicate different faults. If the “Alarm” light on, please log in to the PowerLite APP to view the fault information and contact the supplier</p>								

3 Installation guide

3.1 Installation site requirements

3.1.1 Environmental requirements

- Ambient temperature: -20°C~+55°C (recommended: 10°C~35°C or 50°F~95°F).
- Ambient humidity: 5-95%.
- Altitude < 4000 meters.
- For indoor or outdoor installation
 - Avoid direct sunlight
 - Avoid rain and snow
 - Avoid flood-prone locations
 - Install under the shed if possible
 - 300mm of clearance from doors, windows, driveways
 - Keep away from heating equipment.
 - Protection against corrosive chemicals
 - Prevent water from spilling
- Consider locations with ventilation fans, smoke, heat or combustible gas detectors.



Warning!

Using Atrix Max+ outside the recommended temperature range (-20°C~55°C) may cause irreversible damage to it.

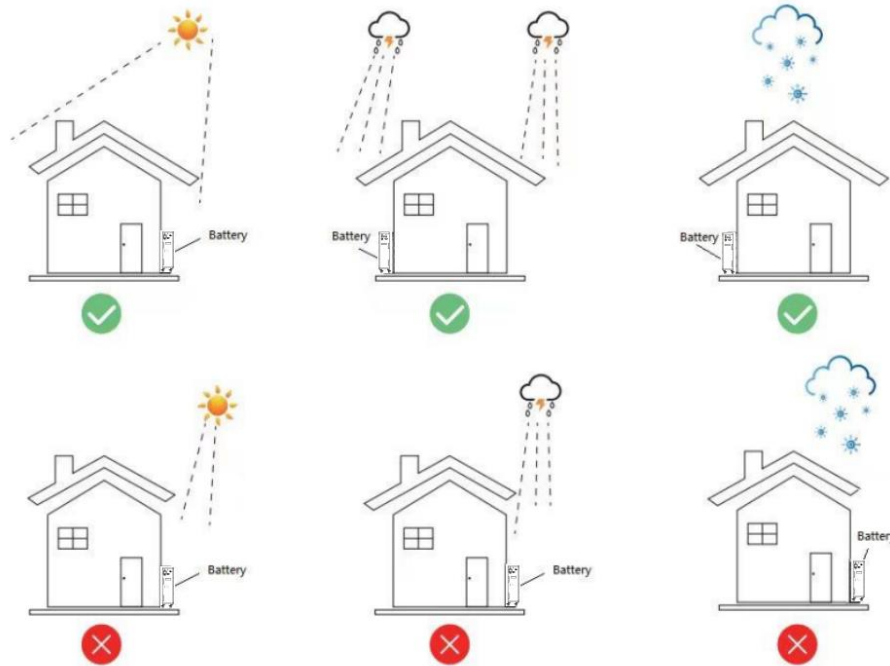

3.1.2 Physical installation requirements



If the battery is floor-mounted installation with wheel, must install the fixed bracket for anti-tipping.

a. Product installation clearance

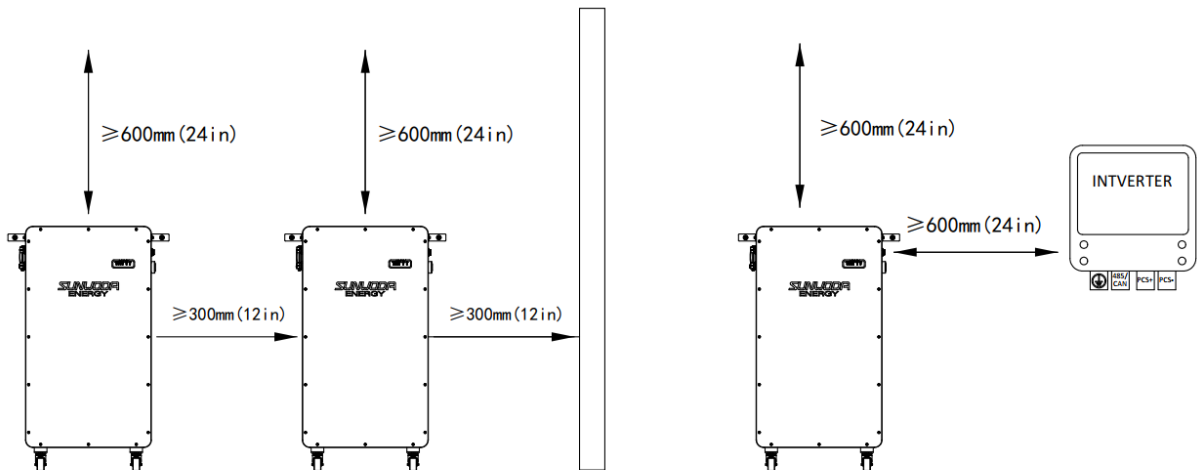

b. Moving



Due to the weight of battery is 130kg (286.6lbs), please be careful to prevent injury and select the suitable way while moving the battery.

- It is recommended to use moving device, such as forklift or trolley.

- If moving the battery by wheel, please move slowly and be careful of the ground bulges.
(Need to release the wheel lock)
- While taking the battery out of the carton, please team lift (at least 4 persons).

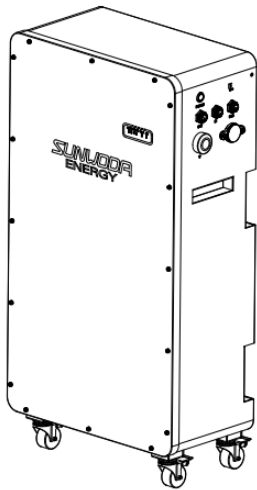
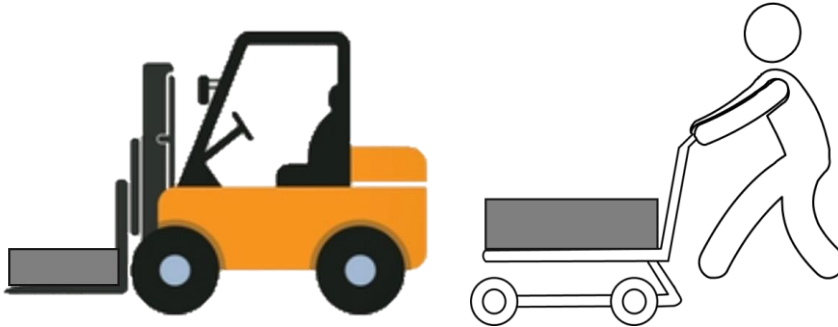

c. Battery Placement

- Please ensure the level of the install ground.
- Please ensure the batteries are mounted in the correct orientation, as shown in the diagram below.

Incorrect placement: The following configurations are prohibited.

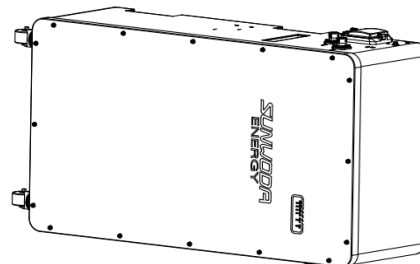
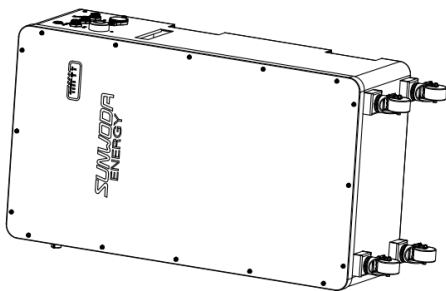

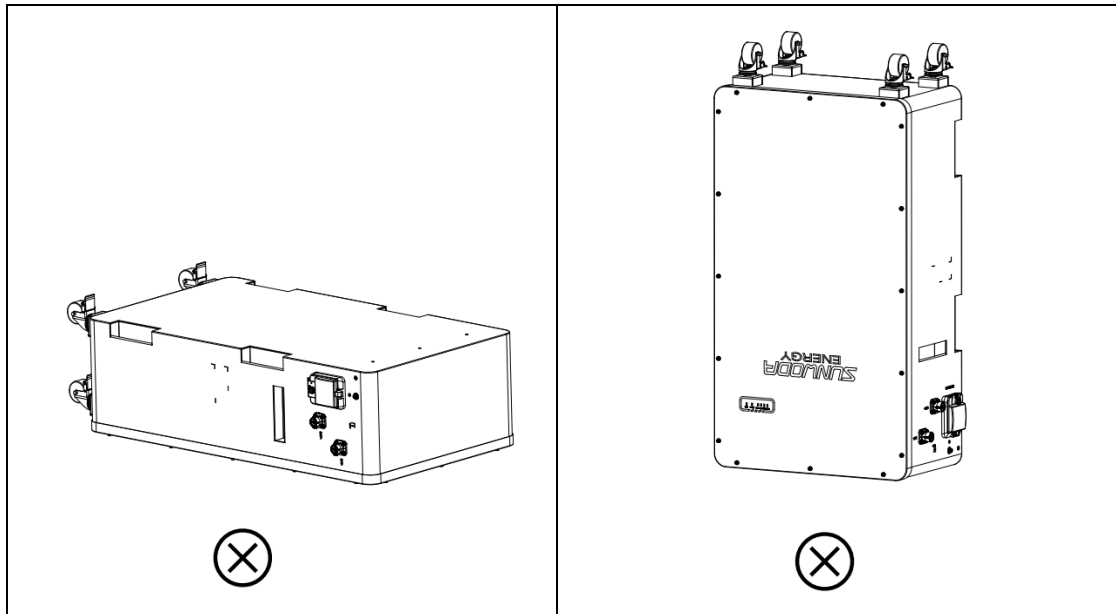



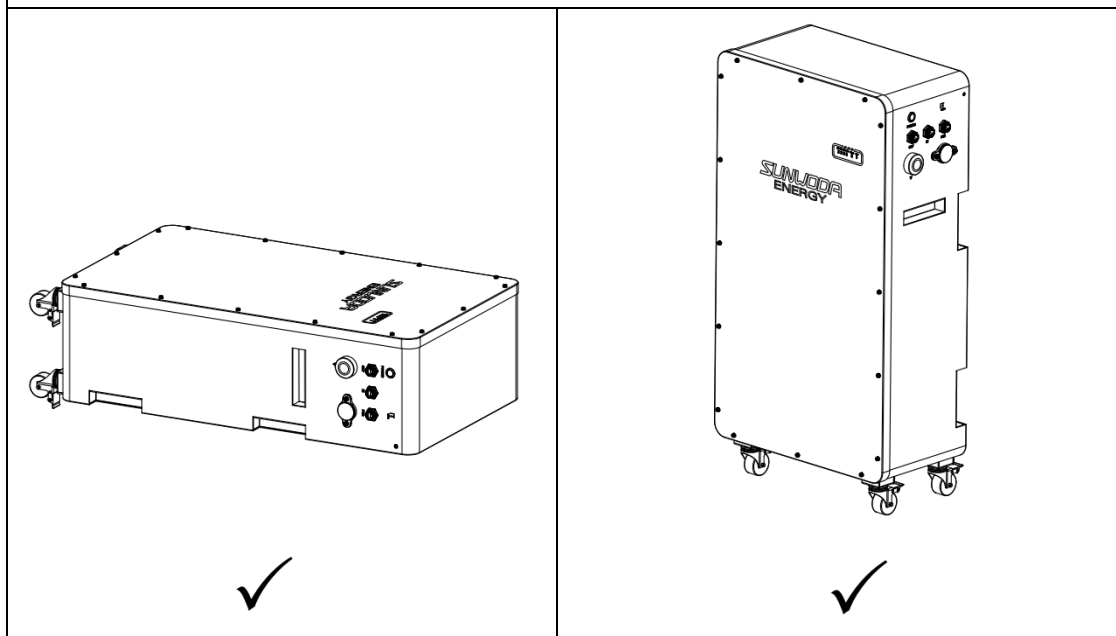



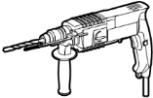



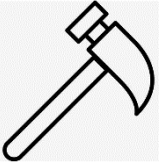

Correct placement: The following configurations are permitted.

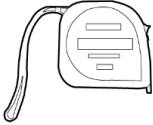







3.1.3 Preparation of installation tools

Tools			
 <p style="text-align: center;">Impact drill (3/8 drill)</p>	 <p style="text-align: center;">Torque wrench (9/16 hexagonal socket)</p>	 <p style="text-align: center;">Forklift</p>	 <p style="text-align: center;">Electric screwdriver</p>

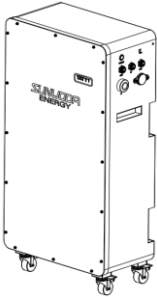
			
Hammer	Detector	Steel tape	Marker pen

Personal Protective Equipment			
			
Safety gloves	Safety goggles	Dust mask	Safety shoes

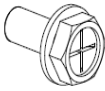
3.1.4 Unboxing guide

Unpacking checklist			
			
Battery module *1	L-bracket *2	Plastic expansion pipe *2	large flat pad($\phi 6*18*2$) *2
			
Self-tapping screws (ST6.3*40) *2	M5*12 screw *3	Grounding Terminals *1	Certificate *1

Cable kit

 <p>Positive cable *1</p>	 <p>Negative cable *1</p>	 <p>Communication cable *1</p>
 <p>Terminal resistor *1</p>	 <p>RJ45 terminal *1</p>	



3.2 Installation steps

•Instructions before installation

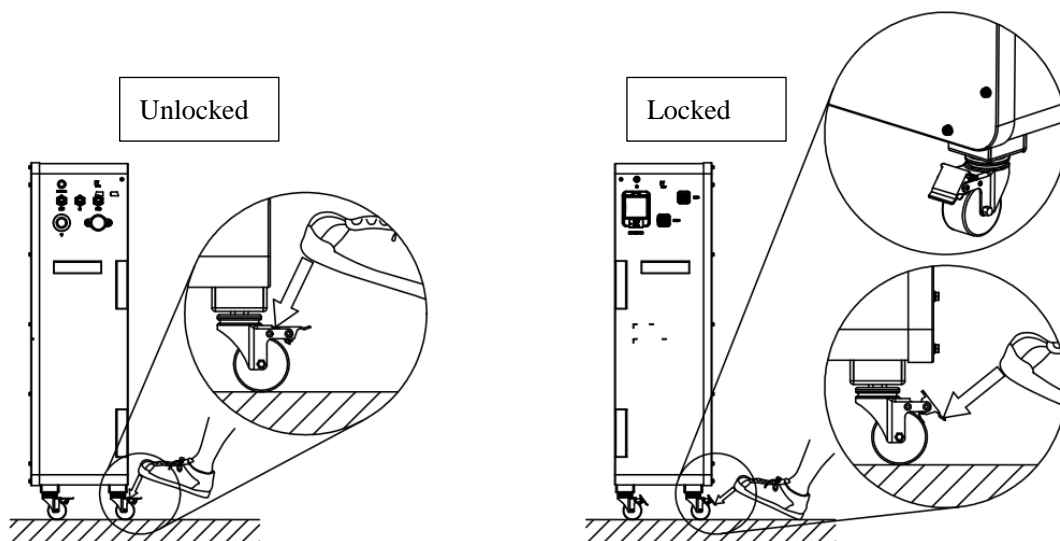
- ①When the lock plate is horizontal, the wheel lock is in the unlocked position. At this time, the product can be pushed to move.
- ②When the foot steps on the end of lock plate, the lock plate is pressed down and the wheel lock is in the locked position. At this time, the product cannot be moved.
- ③Before moving, please check the wheel lock status and move it in the unlocked position.
- ④Do not forcefully push the battery pack when the wheel lock is locked position.



1. Lock the L-bracket to the holes of battery both sides with M5*12 screws

L-bracket	/	2 pcs	
M5*12 screw	M5*12	2 pcs	

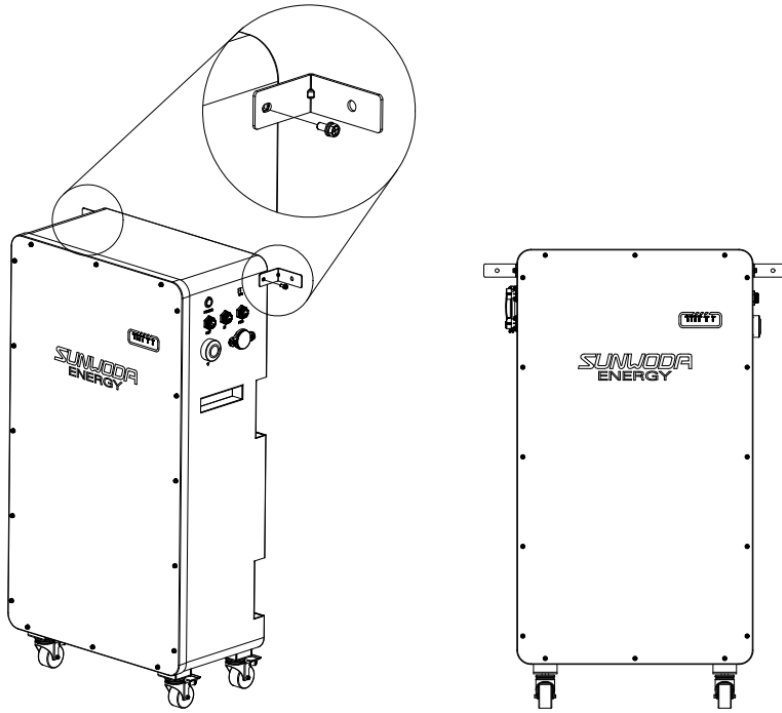

2. Move the battery to the target position. Before punching, mark the fixing points that bracket against the wall with marker.

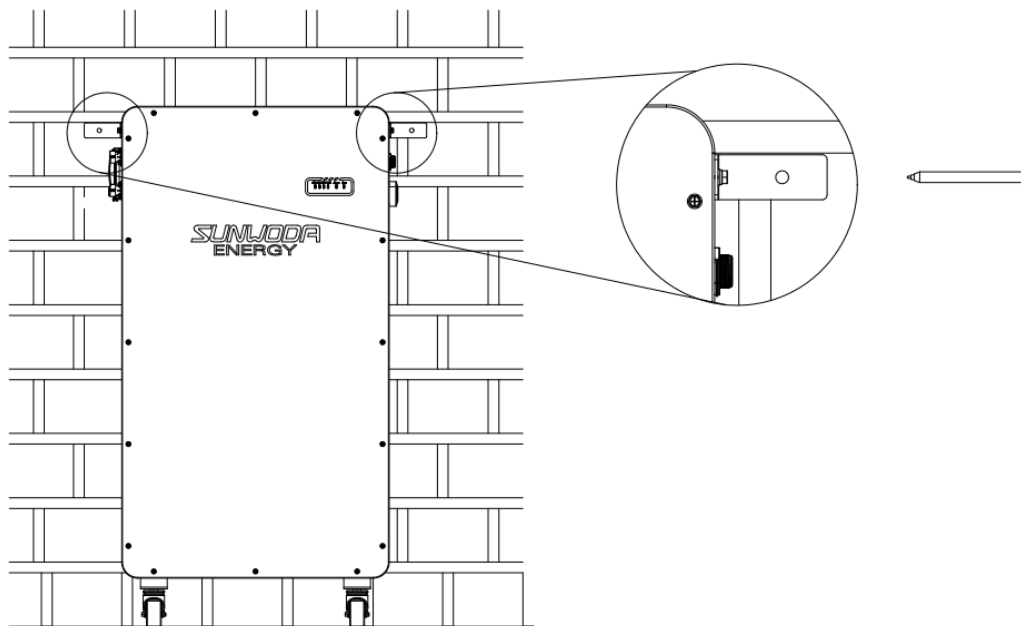

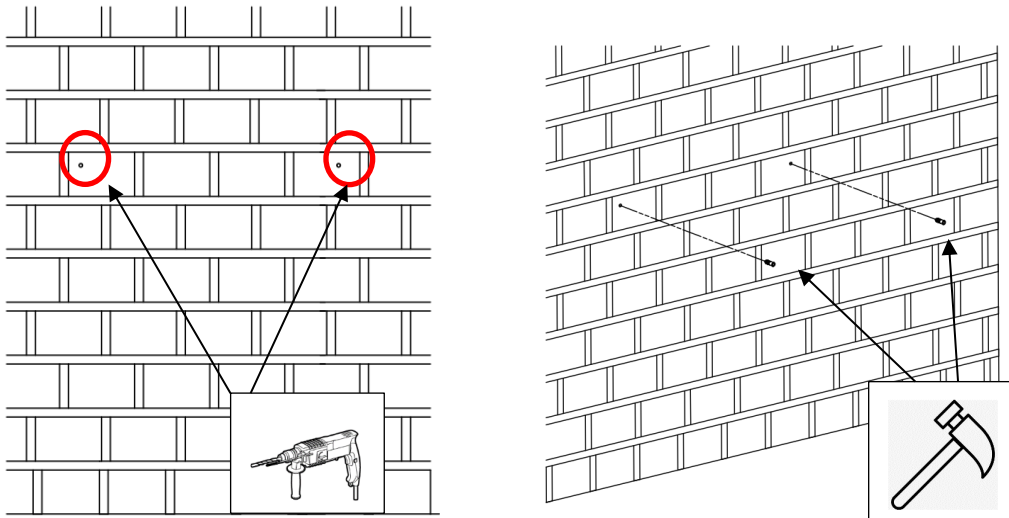

3. Remove the battery and drill the holes on the wall with impact drill. The recommended drilling diameter is 9mm and the drilling depth of approximately 45mm. Then insert the plastic expansion tubes into the holes.

Plastic expansion pipe	$\phi 6*40$	2 pcs	
------------------------	-------------	-------	---



5. Fix the bracket with wall: using the electric screwdriver to fix the self-tapping screws (ST6.3*40) and Large flat pad (M6*18*2) into the wall.

Large flat pad	$\phi 6$	2 pcs	
Self-tapping screws	ST6.3*40	2 pcs	

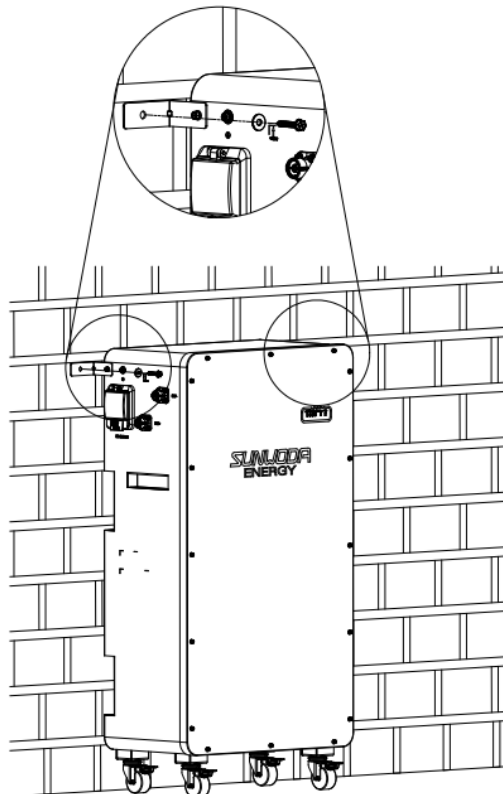

6. Check that the screws are tightly installed and that the battery pack cannot move anymore.

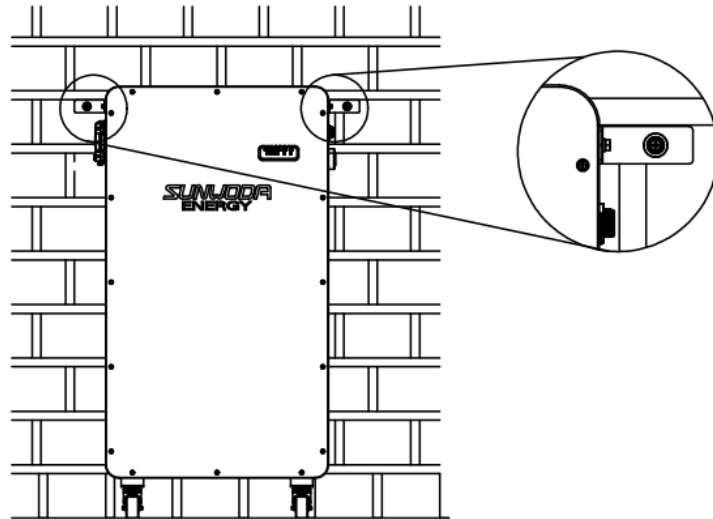

7. After installation is completed, please keep the wheel lock in the locked position.

4 Electrical connection

4.1 Grounding

Grounding point

Join the product ground point to the ground point nearby. The recommended grounding cable specifications are as follows.

Ground cable	8AWG (yellow-green)
Ring terminal	M5
Screw	M5

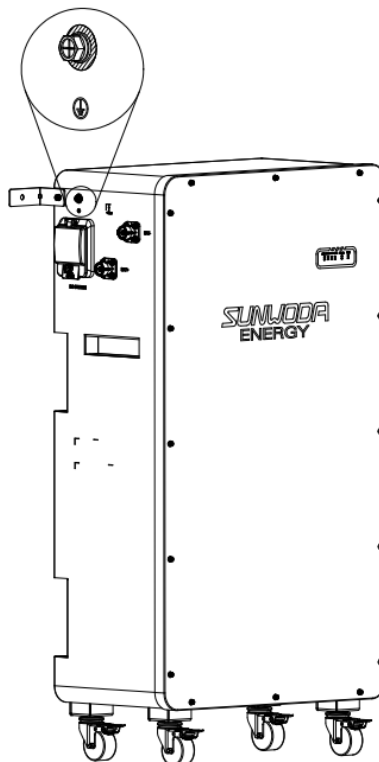

4.2 Cable installation



Ensure that the battery is in shutdown state.

Do not connect the cable while the battery is power on

1. Release the red/black buckle of power cable connector, plug and push the cable connector into the connector on the battery pack. Then lock the connector by pushing forwards the red/black buckle after insertion.

Note: If you want to remove the power cables, please press the red/black buckle down and then pull the connector out.

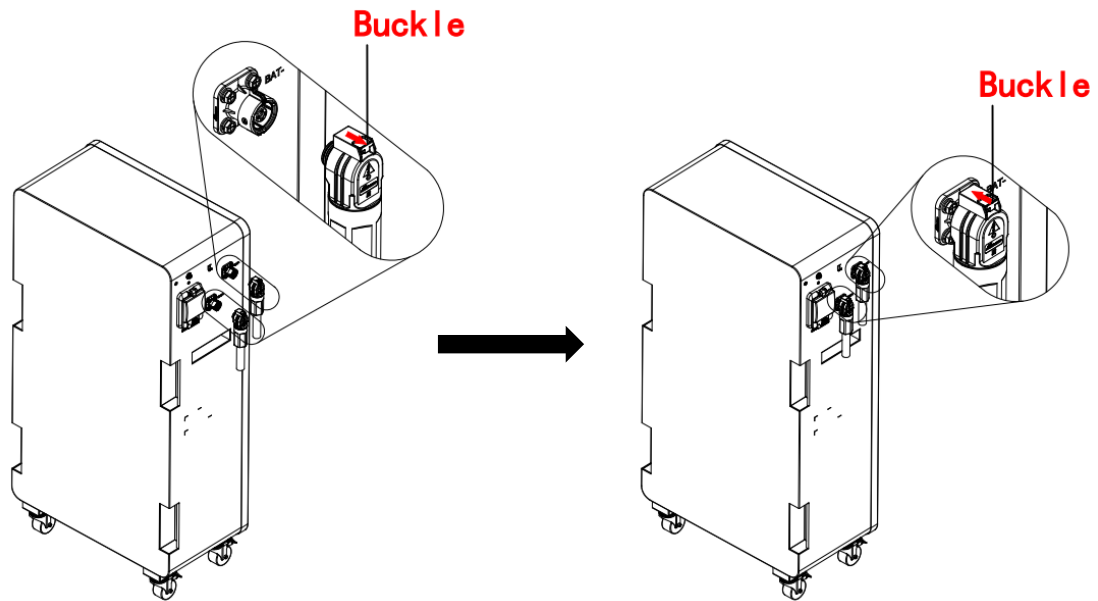

2. First, turn the knob counterclockwise to release the protective cover, and then open protective cover upwards. The circuit breaker can be opened or closed. After the operation is completed, close the protective cover, then rotate it clockwise and tighten the knob to lock the dust cover.

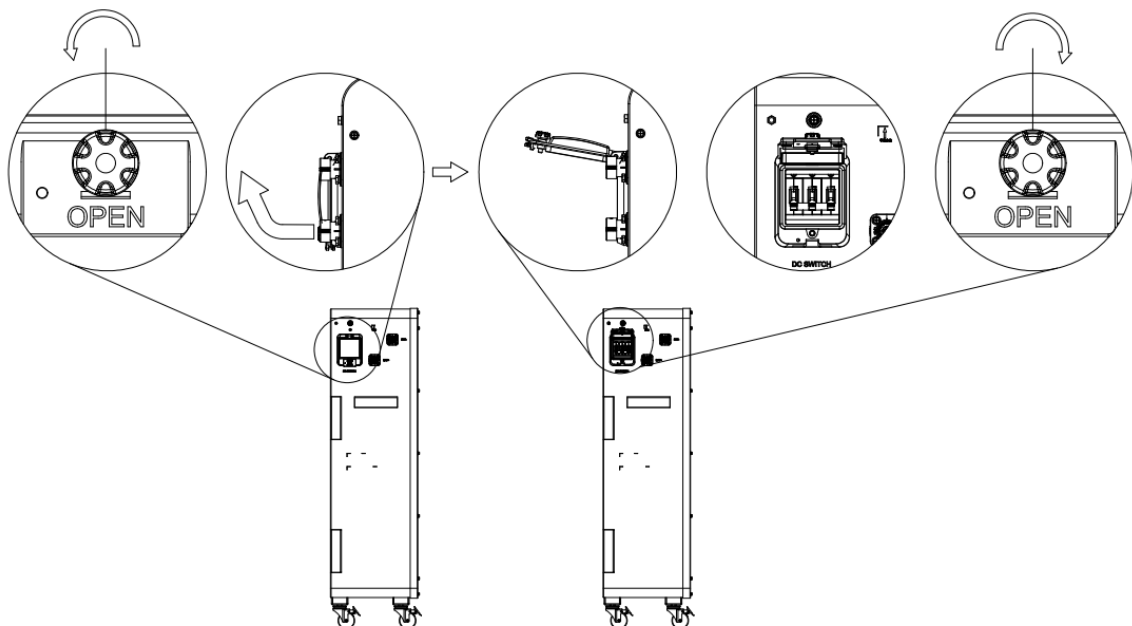

4.3 Guide of electrical connection

● To ensure the safe operation of the system, the appropriate system model and power cable must be selected according to the inverter’s output power. Recommended specifications are provided in the table below:

Table 4-1

Inverter Power	Cable Specifications/Max current	Matching system capacity
3-12kW	1 AWG/42mm ² /220A	16kWh
> 14 kW	1 AWG/42mm ² /220A *N + Combiner Box	≥32KWh
The more compatibility solution about energy system, please connect the after-sales team		

- If the communication cable is customized, ignore the following content.
- Before connecting communication cable with the inverter, please check if the communication pin sequence of battery matches with inverter. If it does not match, please cut off the RJ45 connector at inverter end of the communication cable and adjust the pin sequence according to the pin definitions of both battery and inverter.
- Pin definition of battery “PCS” interface is following:

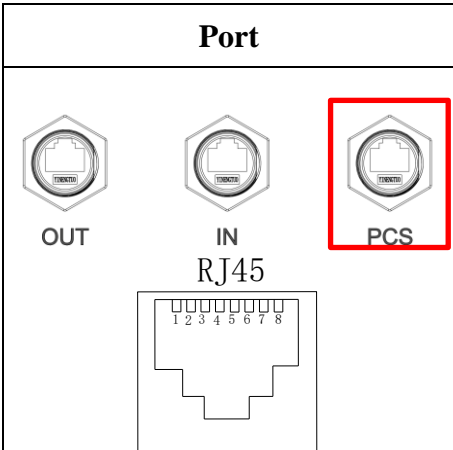
Port	Color	Pin	Function
	Orange-white	1	
	Orange	2	
	Green- white	3	
	Blue	4	CANH
	Blue- white	5	CANL
	Green	6	
	Brown-white	7	RS485A
	Brown	8	RS485B

- Pin definition of some inverter brand that require to change communication cable as examples

Inverter brand	Pin	Victron	Voltronic	Itel (RS485 version)
Pin & definition	1			RS485B
	2			RS485A
	3		RS485B	
	4			
	5		RS485A	
	6			
	7	CANH		
	8	CANL		

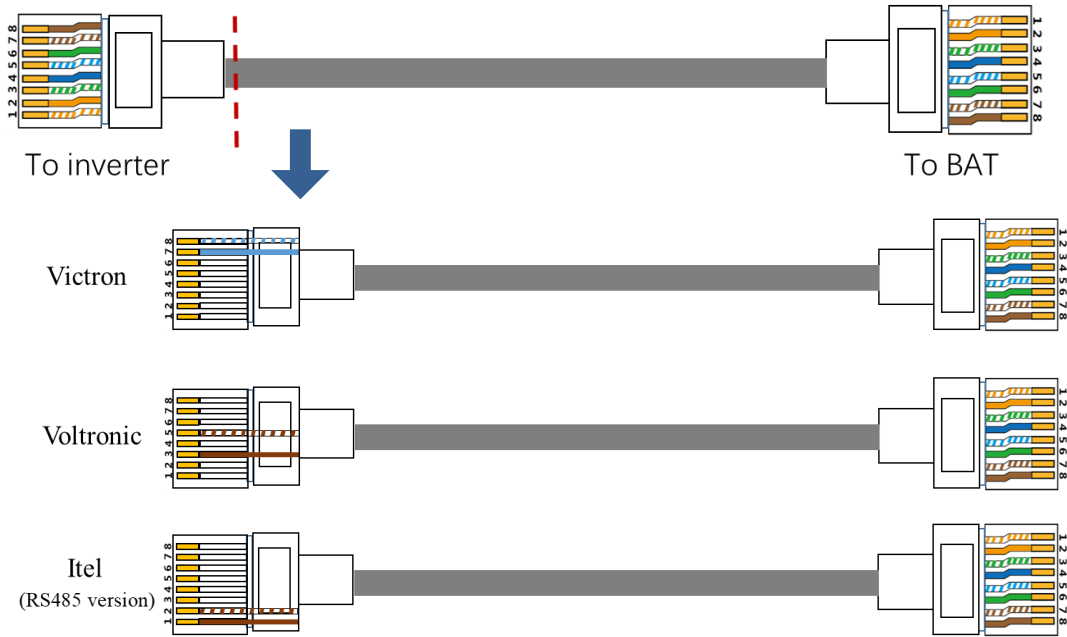

●Electrical connection for a single Atrix Max+ is shown as follows; PCS input: 51.2V

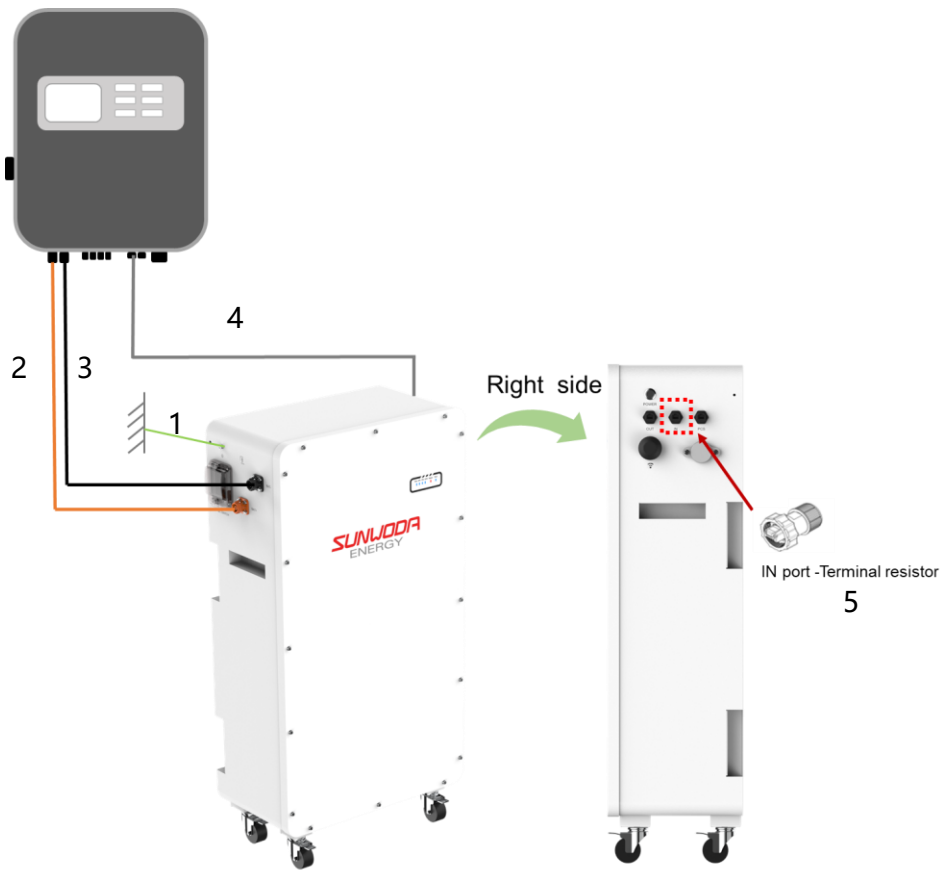

No.	Electrical connection	Cable specifications	Mark
1	Ground protection	Refer to Table 4-1	With grounding terminal
2	Battery power positive to PCS power negative, black, 1.5m	Refer to Table 4-1	PCS-“P-” to BAT-“P-”
3	Battery power negative to PCS power positive, orange, 1.5m	Refer to Table 4-1	PCS-“P+” to BAT-“P+”

4	Communication cable for Battery to PCS, gray, 2m	8P8C	BAT-“PCS” Port to PCS-“BAT” Port
5	Terminal Resistance	120Ω	“IN” port

● Multiple Atrix Max+ in parallel connection is shown below. PCS input voltage: 51.2V.

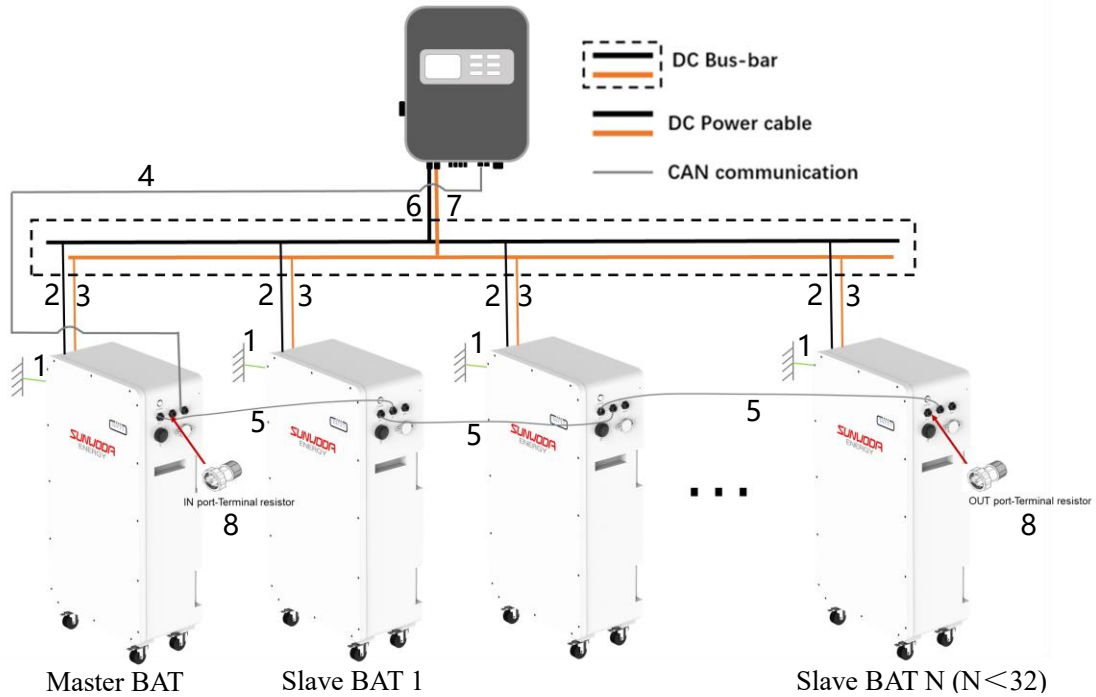

No.	Electrical connection	Cable specifications	Mark
1	Battery module grounding	Non	With grounding terminal
2	Connect the battery negative with combiner box negative, black, 1.5m	Refer to Table 4-1	BAT-“P+” to combiner box negative
3	Connect the battery positive with combiner box positive, orange, 1.5m	Refer to Table 4-1	BAT-“P+” to combiner box positive
4	Communication cable for battery to PCS, gray, 2m	8P8C	Master BAT-“PCS” Port to PCS-“BAT” Port
5	Communication cable for battery to Battery, gray	8P8C	Master BAT-“OUT” port to Slave BAT 1-“IN” port; Slave BAT (N-1)-“OUT” port to Slave BAT N -“IN” port
6	Connect the inverter negative with combiner box negative, black	Based on the system maximum power	Provided by the installer
7	Connect the inverter positive with combiner box positive, orange	Based on the system maximum power	Provided by the installer
8	Terminal Resistor	120Ω	Master BAT -“IN” port; Last BAT - “OUT” port

5 System commissioning



All cables should be connected properly.

5.1 System power on

- ① Turn the DC switch in **ON** state. (If it was turn on after cable connection, here can be ignored)
 - ② Press the power button for more than 3s to start the system, and the indicator will turn on.
- If it is a multi-packs parallel system, press the switch button of any one for more than 3s (need to connect the parallel communication cables and power cables).
- ③ Switch on the inverter (if the inverter has the power switch).

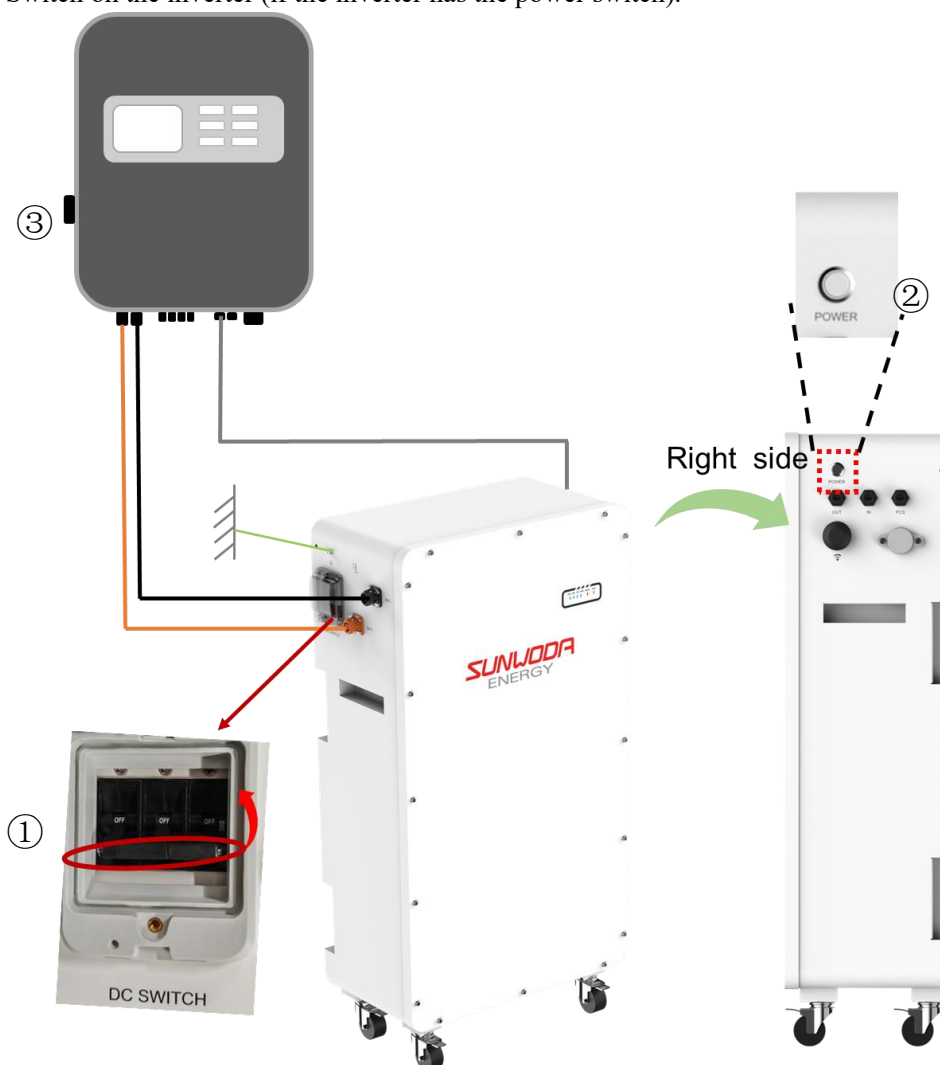

5.2 System power off

- ① Switch off the inverter (if the inverter has the power switch)
 - ② Press the power button for more than 3s, the system will shut down, the indicator will turn off.
- If it is a multi-packs parallel system, press the switch button of any one for more than 3s (need to connect the parallel communication cables and power cables).
- ③ a. If there is any cable operation, please turn the DC switch in **OFF** state before any operation.
b. If there is no cable operation, the system shutdown temporarily. It is no necessary to turn off the DC switch, you can turn off or no.

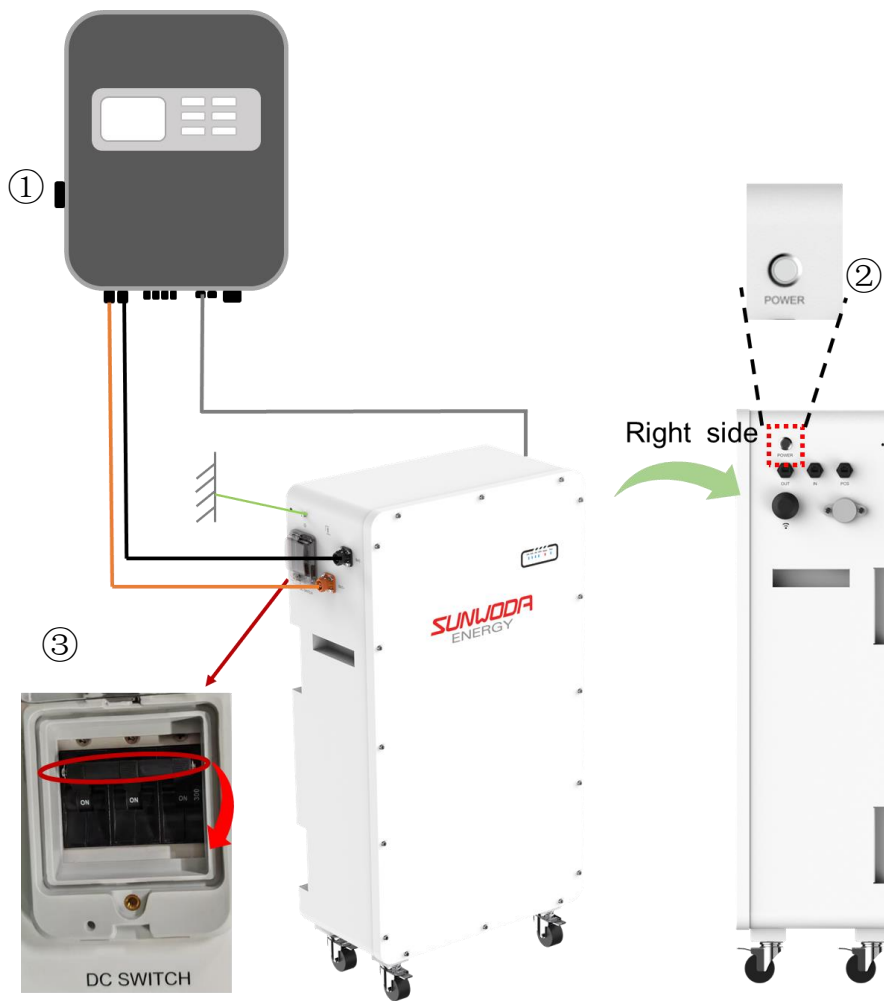

5.3 System configuration

- a. Download and install PowerLite APP

The battery parameter setting and remote monitoring can be realized through the APP software (PowerLite). Please go to the App Store or Google Play to search for "PowerLite" to download and install.

- b. Network configuration

- 1) Turn on the Wi-Fi and Bluetooth signal on your phone
- 2) Click Register to go to register an account



Enter the registration interface and fill in the information, after receiving the verification by email, enter the verification code to complete the registration.

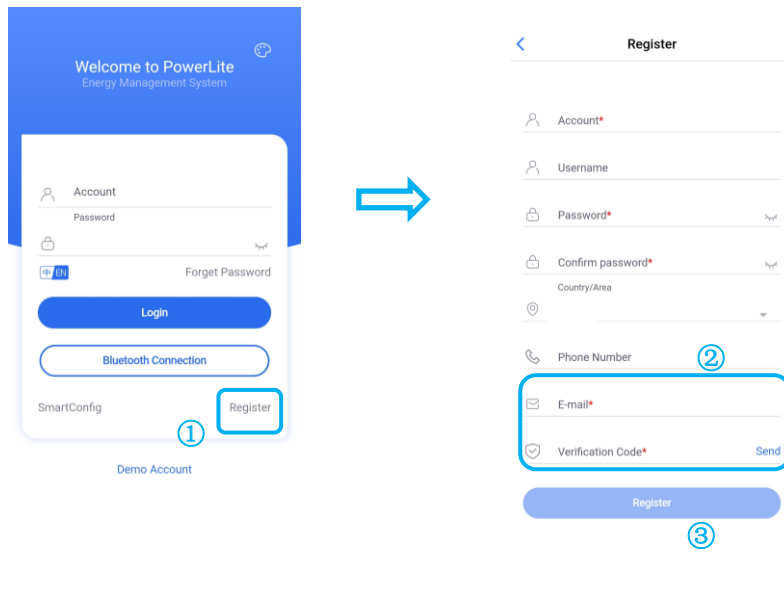

Note: If you have already registered a login account, please ignore this step.

3) Configure the network

(You can check the Bluetooth SN code on the battery module)

- ① Click "SmartConfig";
- ② Select the Bluetooth device corresponding to the battery;
- ③ Enter the WiFi network account and WiFi password;
- ④ Click "SmartConfig" to complete the networking, the APP displays the successful network configuration information and the WiFi icon on the display is always on, that is, the network configuration is completed.

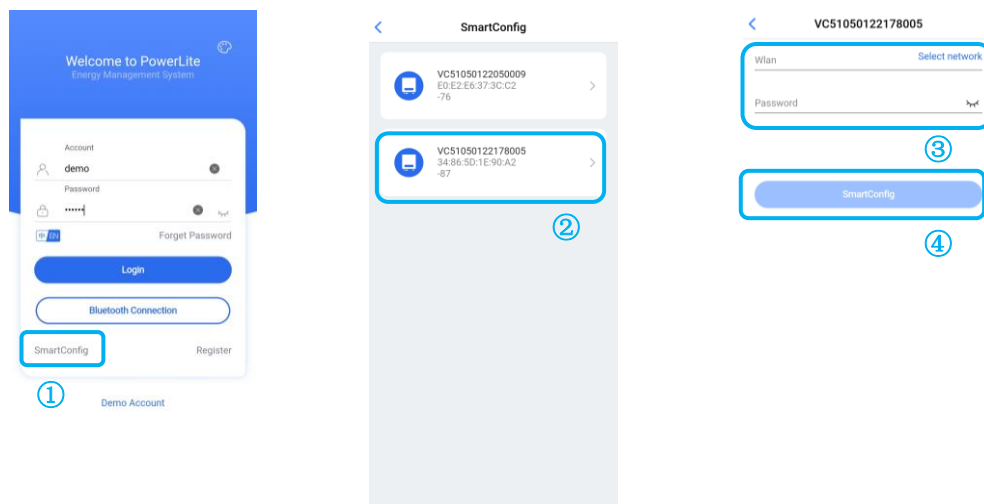

c. Add site/device

(Please check the battery SN)

Enter the account, password and verification code.

- ① Click "Login" to log in;

- ② After logging in, click on the top right corner of the main interface to add a site;
- ③ After recommending a power station, then add equipment;
- ④ Select the SN code on the Data module to add;
- ⑤ And simultaneously click "Assigned Plant" to bind the battery equipment to the established power station, complete the site/device addition.

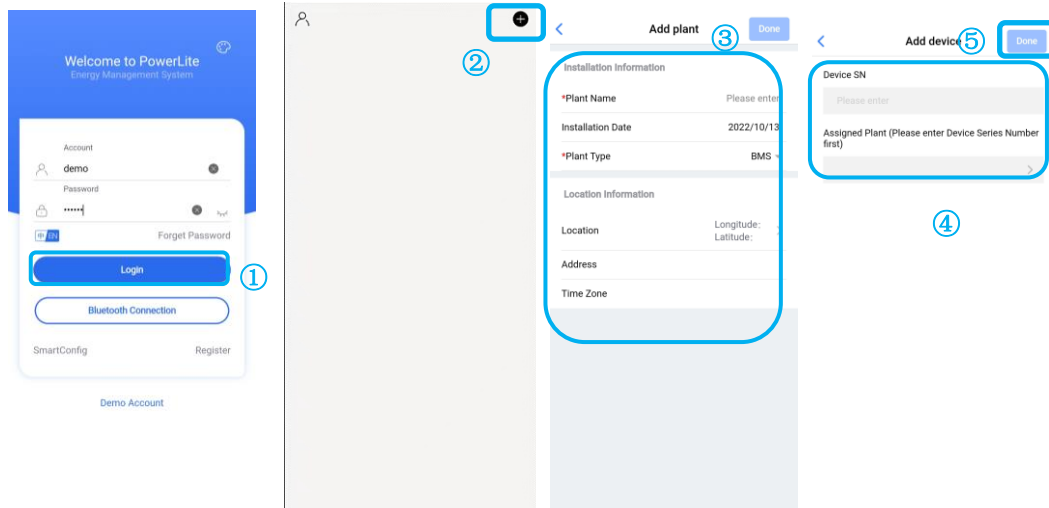

Note: The configuration steps will be finished after step c.

Atrix Max+ can automatically adapt to the inverter protocol, it doesn't need to set the inverter manufacturer parameters. Please check the compatibility list of matching compatible inverters

6 Maintenance and troubleshooting

6.1 Routine maintenance

- Maintenance charge every 6 months

From the date of manufacturer shipment, the battery shall be maintained every 6 months. Action must be taken in case SOC reaches 0% according to the table below:

Ambient temperature	Must be recharged within
(45, 50] °C	7 days
(35, 45] °C	15 days
≤35°C	30 days

- Disconnect the battery if not being used
BMS consumes power even when the battery is not being used. Disconnect the battery output to prevent the battery from becoming empty. For store-away, make sure the SOC is between 45% and 55% before disconnect.
- Check the battery system regularly. Contact your support if any anomaly detected.

- After the battery is fully discharged, it needs to be charged continuously until the SOC \geq 5%.

6.2 Fault checklist

Fault	Cause	Solution
POWER button no response	1. Damaged POWER button 2. Damaged cable or poor contact	1. Repair or replace the battery POWER button 2. Please contact the supplier
Short discharge time	Battery SOC is low	Charge the system in time. Keep the SOC exceeds the minimum protection energy value
	Low ambient temperature	Guarantee the product works under the recommended temperature range
	Product overload	Check load status and remove non-essential loads
	Batteries age and capacity decreases	Please contact the supplier to replace the battery and its components
Unable to charge and discharge	Internal failure	Log in to the PowerLite APP to view the fault information and contact the supplier
	Battery report charging or discharging protection failure	Log in to the PowerLite APP to view the fault information and contact the supplier
	After the battery is discharged to the SOC protection value, it needs to be charged for a period of time before it is allowed to discharge.	The battery is charged to the SOC value set by the restart
	Battery over temperature	Stand at room temperature for more than 3 hours
The system is powered on, but the LED cannot be lit	LED failure	Please contact the supplier to repair or replace the battery module
The LED cannot wake up during system operation	1. If the LED is off, the POWER button is faulty or the button wiring is loose 2. If the LED still does not light up after restarting, the LED is faulty	Please contact the supplier to repair or replace the battery module
Abnormal battery communication	Communication disconnection	Check whether the battery stack is installed reliably.
The heater works abnormally	Heating circuit failure	Log in to the PowerLite APP to view the fault information and contact the supplier
Abnormal Bluetooth connection	Bluetooth account connect error	Check whether the paired Bluetooth is consistent with the installed product
Abnormal WiFi connection	1. The WiFi connection is misconfigured 2. The WiFi module is abnormal and the line connection is abnormal	1. Check if the battery WiFi connection configuration is correct 2. Check whether the antenna is installed or connected reliably
The inverter is powered on for the first time through the battery, and the battery reports short-circuit protection	The parallel capacitor value of the input terminal on the battery side of the inverter is large	Battery protection can be automatically restored
Inverter won't start	The battery voltage is too low or the SOC is lower than the shutdown protection value	Charge the battery after starting the inverter from the grid

7 Warehouse storage guidelines

7.1 Packaging guidelines

Lithium-ion batteries are recognized as dangerous goods. The packaging requirements for battery products are as follows:

- a. The packaging manufacturer with the packaging qualification for dangerous goods is responsible for providing product packaging, and the packaging manufacturer has a record in the local Commodity Inspection Bureau;
- b. After the packaging manufacturer completes the packaging, the supplier needs to apply to the Commodity Inspection Bureau, and the Commodity Inspection Bureau will provide the "Dangerous Package Product Use Inspection Sheet" and "Dangerous package product performance inspection sheet", and complete the dangerous package commodity inspection;
- c. All battery packs should be packaged with product instruction manuals. The packaged product should be placed in a dry, dust-proof and moisture-proof packing box;
- d. The product name, model, quantity, gross weight, manufacturer, and ex-factory date should be marked on the outside of the packing box;
- e. The necessary signs such as "upward" and "fear of fire" shall meet the requirements of GB/T 191;
- f. The packing method is: packing in a carton with molded foam buffer material in the carton;
- g. Accessories packaging: single accessories are first fastened with cardboard or plastic film or braided straps, neatly placed in the carton, and filled with regular fillers (foam pads, cardboard, etc.) to prevent the accessories from shifting in the box. The following documents should be included with the product when leaving the factory:
 - 1) Product certificate;
 - 2) Product user manual;
 - 3) Product packing list.
- h. Clean battery
Regular cleaning of the battery system is recommended. If the equipment is dirty, use a soft dry brush or dust collector to remove the dust. Cleaning liquid materials include solvents, abrasives, etc. Corrosive liquids should not be used for cleaning the housing.
- i. Packaging

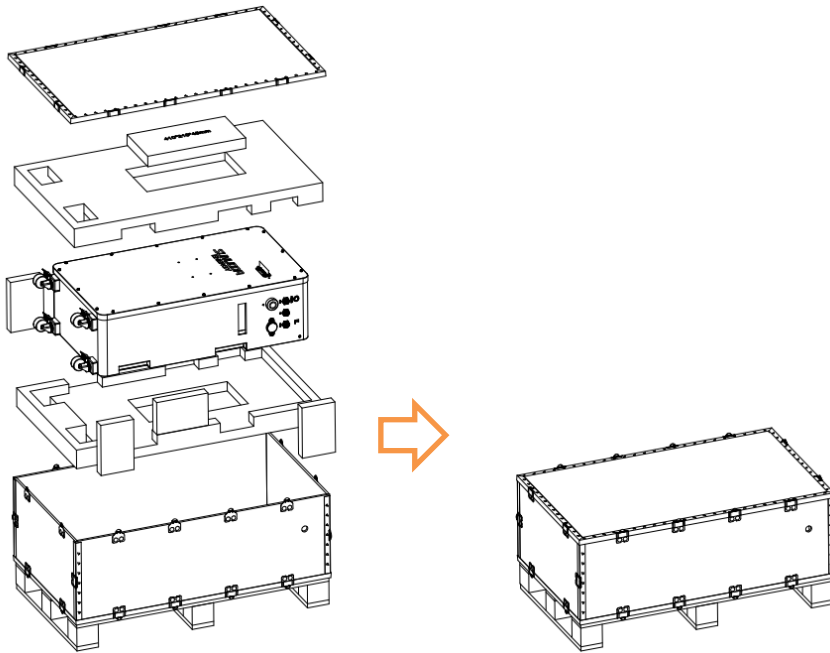

7.2 Storage

The battery pack is stored in a clean, dry and ventilated room with an ambient temperature of $25^{\circ}\text{C}\pm 5^{\circ}\text{C}$ and a relative humidity of not more than 75%. The battery pack has a state of charge of 45% to 55%. Avoid contact with corrosive substances and keep away from fire and heat sources.

8 Dispose of used batteries

Comply with applicable local regulations for the disposal of electronic waste and used batteries.

- Do not mix with your household waste.
- Do not expose the battery to high temperatures or direct sunlight.
- Do not expose batteries to high humidity or corrosive environments.

Contact the supplier or original manufacturer for disposal options.

9 Detailed parameter

Item	Battery Module Parameter
Battery model	Atrix Max-16L-P
Cell type	LFP
Rated voltage	51.2V
Voltage range	44.8V~57.6V
Connection	1P16S
Rated energy	16 kWh
Rated capacity	314Ah
Dimension(W* H * D)	500*970*265mm
Weight	130kg
Internal resistance	<10mΩ
Rated charging/discharging current	157A/157A
Max charging /discharging current	220A/220A
Peak discharge current	300A/5min
Communication	CAN/RS485/WiFi
Dissipation	Natural convection
Protection function	Charging over voltage, discharging under voltage, over current, over temperature, short circuit protection
Scalability	Up to 32pcs in parallel
Enclosure type	IP65
Fire-fighting system	Built-in aerosol fire extinguishing
Ambient temperature	Charging: [-20,55]°C
	Discharging: [-20,55]°C
Ambient humidity	5%~95%RH
Working altitude	<4000m
Certificate	IEC62619,CE,UN38.3,EN18031