

1. Overview

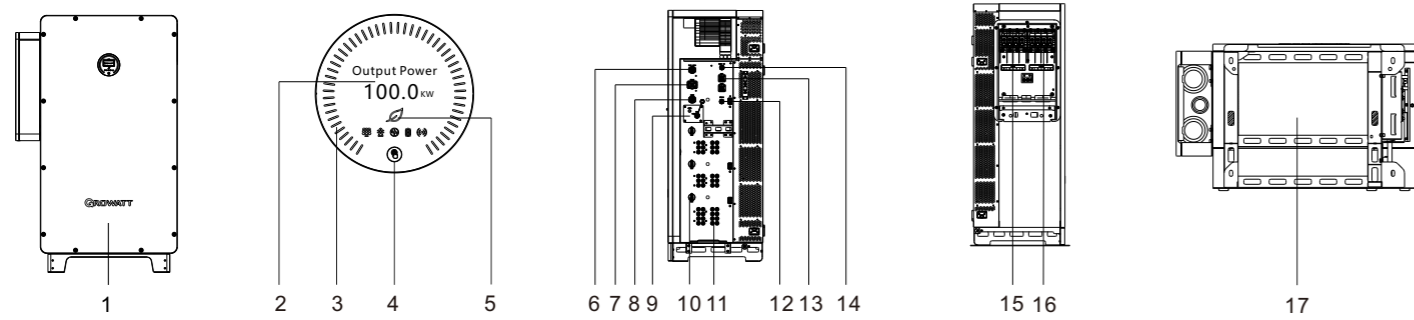

- (1)Front panel (2)OLED display screen (3)Battery status indicator (4)Push button (5)System indicator
- (6)BMS communication port (7)Parallel communication port (8)Monitor communication port (9)Communication port (10)DC switch
- (11)PV terminal (12)Network communication port (13)Battery terminal (14)BMS power supply port
- (15)GRID terminal (16)LOAD terminal (17)Base

Notes:

- The content of this document is continually reviewed and amended, where necessary. Growatt reserves the right to make changes to the material at any time and without notice. Unless otherwise agreed, this document is for quick installation guidance only. All information and suggestions in this document do not constitute a warranty of any kind, express or implied. Growatt reserves all rights for final explanation.
- This document is for quick installation guidance only. For details, please refer to the User Manual.
- Machine damage caused by failure to follow the instructions is not covered under any warranty.

2. Installation

System overview

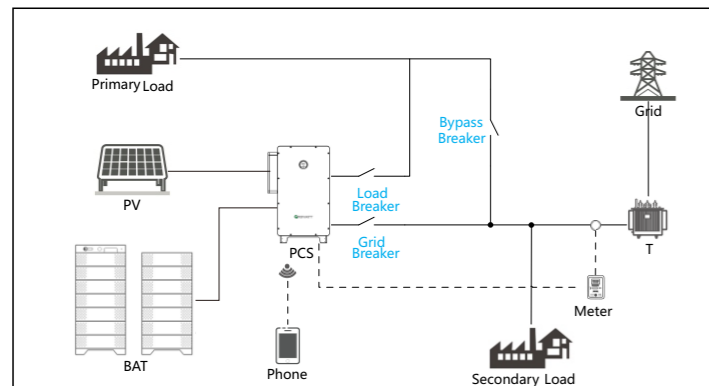

2.1 Installation requirements

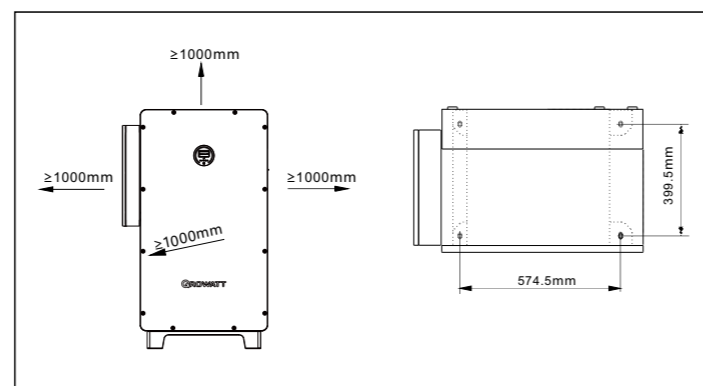

2.2 Floor-mounted installation

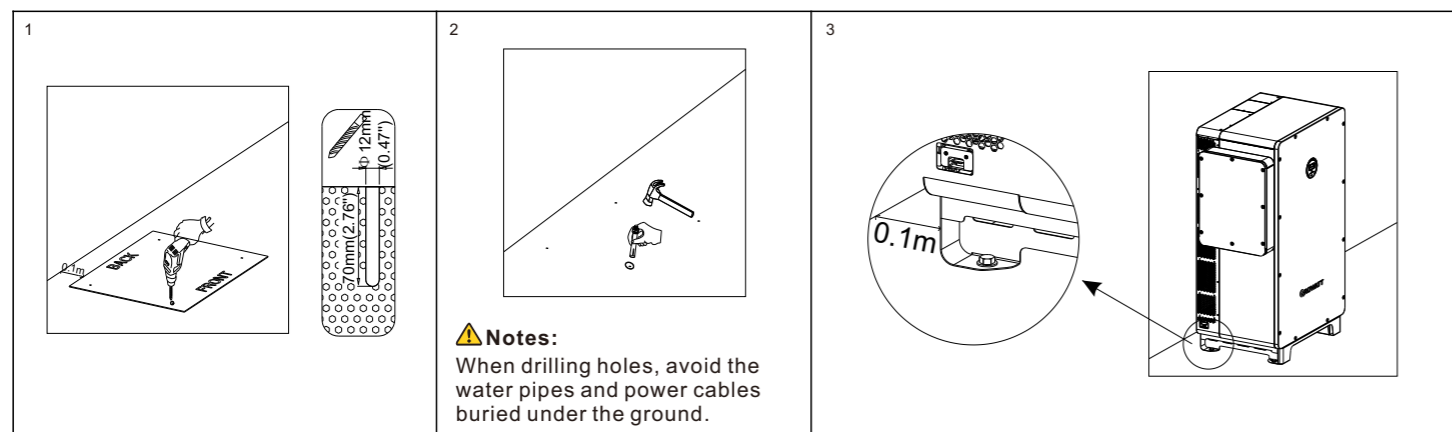

Notes:

- When determining the installation position of the inverter, please consider the position of the batteries and the distribution panel.
- For export limitation, you are advised to connect an energy meter and current transformers to the inverter.

3. Connecting cables

Please prepare the cables listed below before electrical connections.

No.	Cable	Type	Recommended specifications
1	Grounding cable	A multiple-core copper cable (yellow and green)	50mm ²
2	Grid cable	A multi-core copper cable	120mm ² -300mm ²
3	Load cable	A multi-core copper cable	70mm ² -150mm ²
4	PV input cable	Photovoltaic cable	4mm ² -6mm ²
5	Battery power supply cable	A single-core copper cable (red and black)	50mm ²
6	BMS power supply cable	A multi-core copper cable	0.5mm ² -2.5mm ²
7	Other communication cable	RS485	/

Notes:

- Make sure all switches are OFF before connecting the cables. For personal safety, do not operate when power-on.
- If the diameter of the cable does not match the terminal, or the cable is aluminum wire, please contact our after-sales personnel.

3.1 Grounding

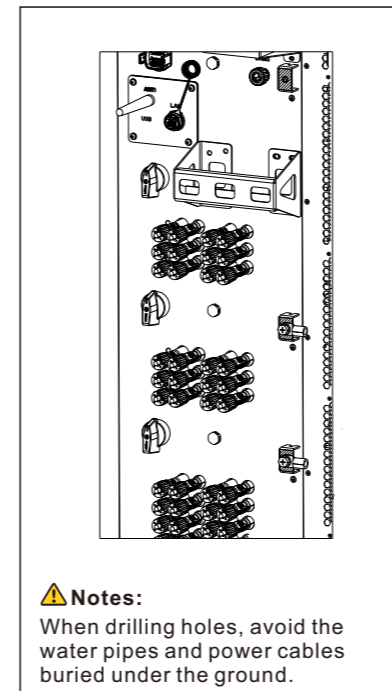

3.2 GRID and LOAD side cable connection

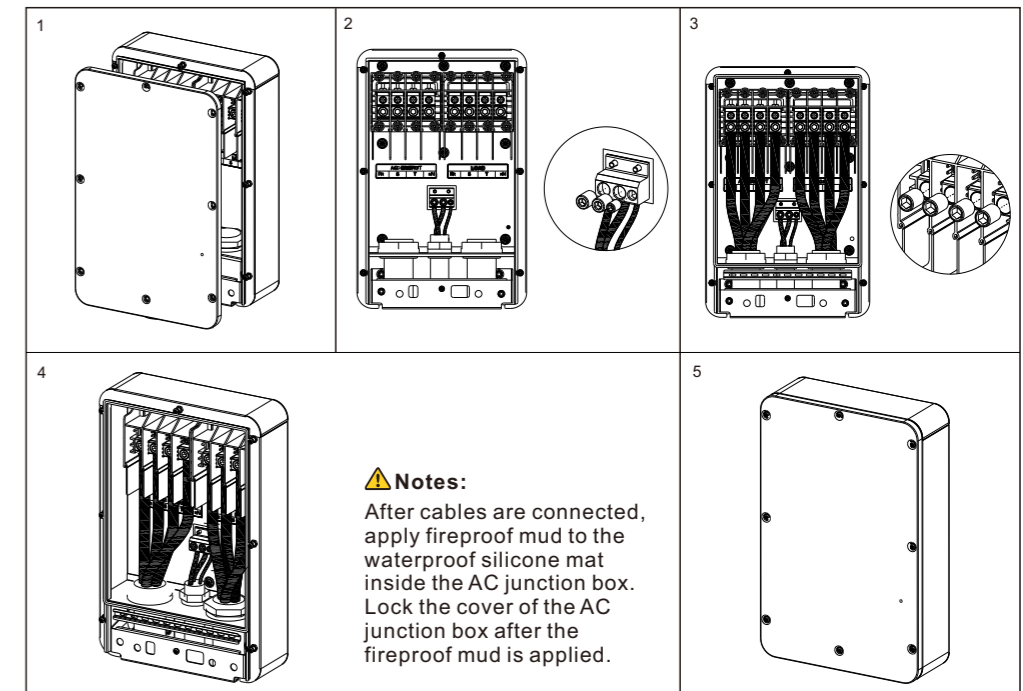

3.3 DC connection

3.3.1 Assembling the PV connectors

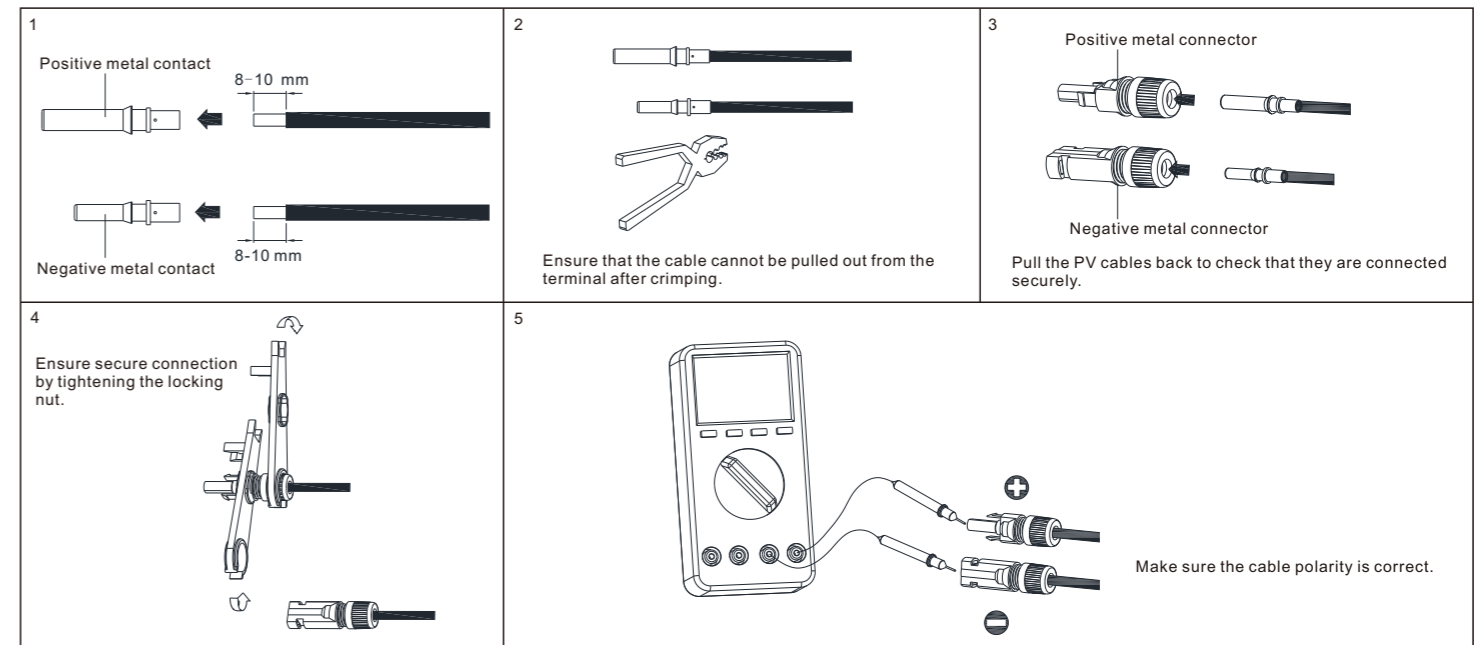

3.3.2 Connecting the DC input cables

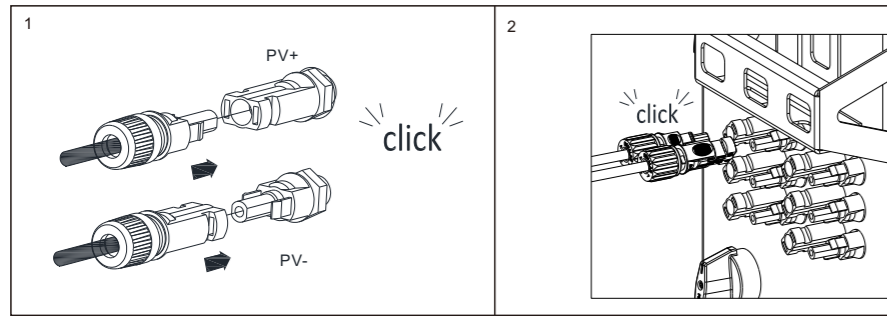

Notes:

1. Before installing the PV terminals, please confirm that the PV input voltage and current do not exceed the MPPT limits.
2. When installing the PV terminals, identify the positive and negative terminals and connect them to the inverter respectively following the color convention.
3. A "click" sound will be heard when the terminal is connected. Please gently pull the PV cable back to make sure it is securely connected.

3.4 Connection on the battery side

3.4.1 Connecting the battery power cable

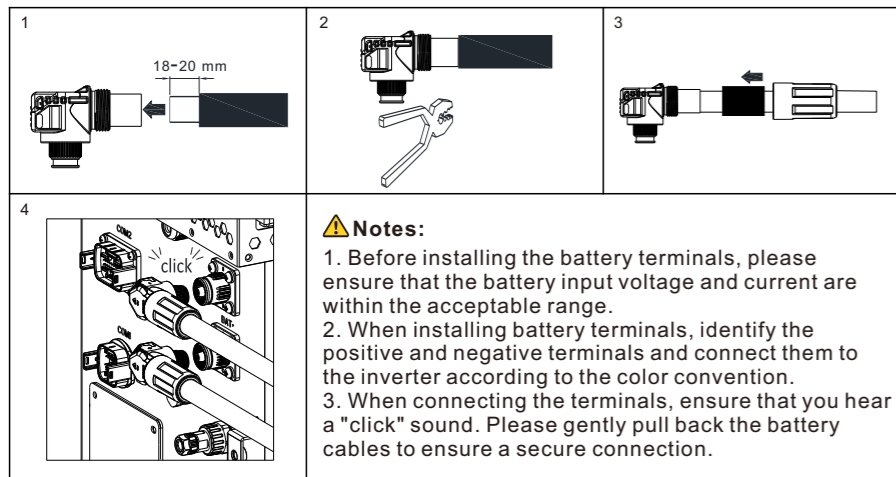

Notes:

1. Before installing the battery terminals, please ensure that the battery input voltage and current are within the acceptable range.
2. When installing battery terminals, identify the positive and negative terminals and connect them to the inverter according to the color convention.
3. When connecting the terminals, ensure that you hear a "click" sound. Please gently pull back the battery cables to ensure a secure connection.

3.4.2 Connecting the BMS power supply cable

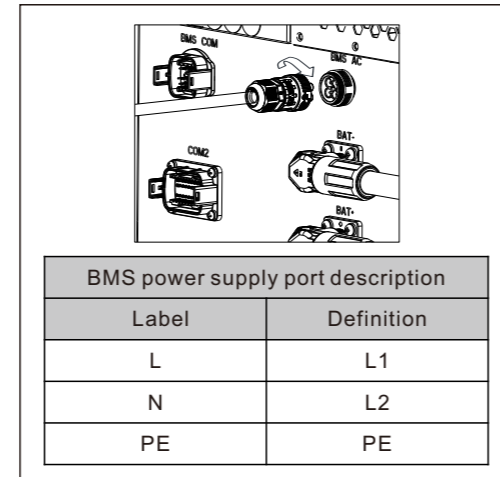

BMS power supply port description	
Label	Definition
L	L1
N	L2
PE	PE

3.5 Communication cable installation

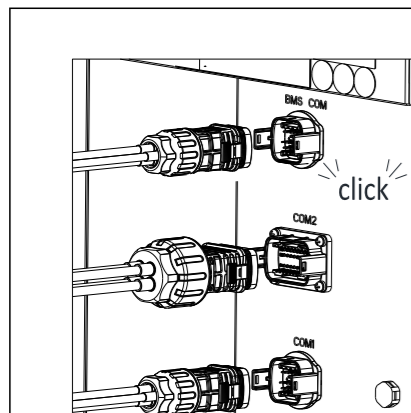

Monitor communication port

Monitor communication port description(COM1)			
No.	Description	No.	Description
1	RS485A4	9	RS485B2
2	RS485B4	10	Res_RS4851B
3	RS485A1	11	PE
4	RS485B1	12	REPO1
5	Res_RS4851A	13	REPO2
6	RS485A2	14	DO1
7	RS485B2	15	DO2
8	RS485A2	16	PE

Parallel communication port

Parallel communication port description(COM2)			
No.	Description	No.	Description
1	24V.S	16	CAN2_H
2	GND.S	17	CAN2_L
3	CAN1_H	18	RS485_1A
4	CAN1_L	19	RS485_1A
5	GND.S	20	PE
6	CAN2_H	21	RS485_5A
7	CAN2_L	22	RS485_5B
8	RS485_1A	23	RS485_5A
9	RS485_1B	24	RS485_5B
10	PE	25	RS485_4A
11	24V.S	26	RS485_4B
12	GND.S	27	RS485_4A
13	CAN1_H	28	RS485_4B
14	CAN1_L	29	ATS_CAN205_H
15	GND.S	30	ATS_CAN205_L

BMS communication port

BMS Communication port description(BMS-COM)			
No.	Description	No.	Description
1	Wakeup+	6	CANL
2	Wakeup-	7	CAN.GND
3	RS485A3	8	Di1
4	RS485B3	9	Di2
5	CANH	16	PE

Network communication port

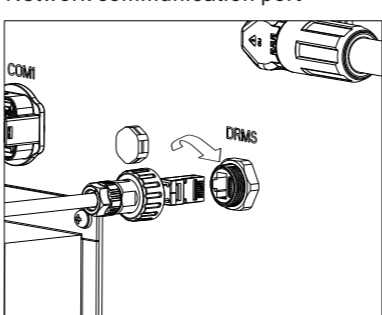

Follow the installation steps:

1. Remove the waterproof cover from the network communication port.
2. Insert a network cable into the port and tighten the protective cover.

3.5.6 Installing the antenna

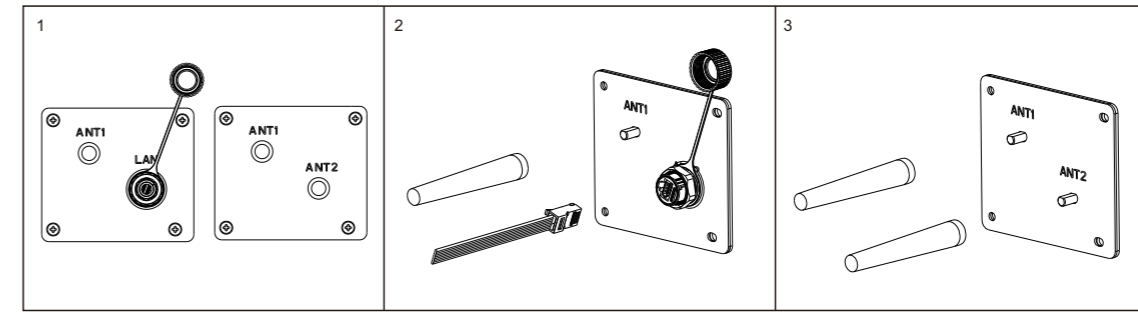

Please follow the steps below:

1. Remove the antenna dust cap or the protective cover from the network port.
2. Install the antenna as shown in the diagram.
3. Connect the antenna to the inverter correctly and tighten it.

4. Post-installation check

Number	Checking item	Number	Checking item
1	The hybrid inverter is installed correctly and reliably.	2	Ground cables are connected securely.
3	All switches are in the OFF position.	4	All cables are connected correctly and securely.
5	The cover of the AC junction box is secured.	6	All the unused connectors are sealed.
7	The right panel is closed and secured.	8	Put away the unused accessories.
9	The installation position is clean and tidy.		

5. Powering on/off the inverter

Note:

Before power-on, please make sure all the voltage and current are within the specified range. Otherwise it will cause damage to the hybrid inverter.

Perform the following steps to power on the system:

1. Ensure that there is no voltage on the PV side, then turn on the DC switches.
2. Turn on the breaker between the grid and the inverter.
3. Turn on the breaker between the battery and the inverter, then turn on the switch on the battery.
4. The system will be powered on automatically when all the requirements are met.

To shut down the system, you need to send a shutdown command on the APP or website. Wait until the system is completely powered off, then turn off the switches in reverse order.

6. Description of the display panel

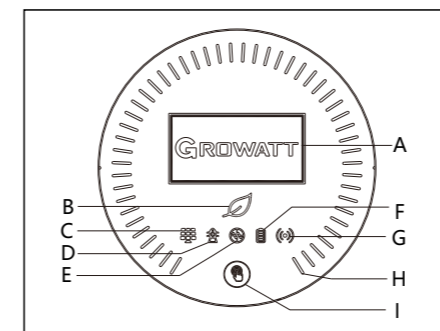

Indicator	Function	Indicator	Function
A	OLED display screen	F	Battery connection indicator
B	System indicator	G	Communication indicator
C	PV indicator	H	Battery status indicator
D	On-grid Indicator	I	Push button
E	Off-grid indicator		

7. Service and contact

Growatt USA, Inc
 9227 Reseda Blvd, #435 Northridge, CA 91324, USA.
 T 866-686-0298
 E usaservice@ginverter.com
 W www.growatt-america.com



Download Manual



Growatt New Energy