



# TECHNICAL GUIDE FOR INSTALLATIONS WITH ISS 1PLAY TL M

## SELF CONSUMPTION INSTALLATION

---

DESIGNED BY	<i>B.R.S</i>
DATE	<i>27/03/2020</i>
REVISED BY	
REVISION DATE	
APPROVED BY	<i>D.B.R</i>

---

"The reproduction, distribution and utilization of this document as well as the communication of its contents to others without express authorization is prohibited. Offenders will be held liable for the payment of damages. All rights reserved."  
ISO 16016

"Sin expresa autorización de Ingeteam, queda terminantemente prohibida la reproducción total o parcial de este documento, así como su uso indebido y/o exhibición o comunicación a terceros. De los infractores se exigirá el correspondiente resarcimiento de daños y perjuicios. Quedan reservados todos los derechos."  
ISO 16016

					Date	27/03/2020
					Designed	B.R.S
					Revised	
Rev	Date	Designed	Revised	Approved	Approved	D.B.R





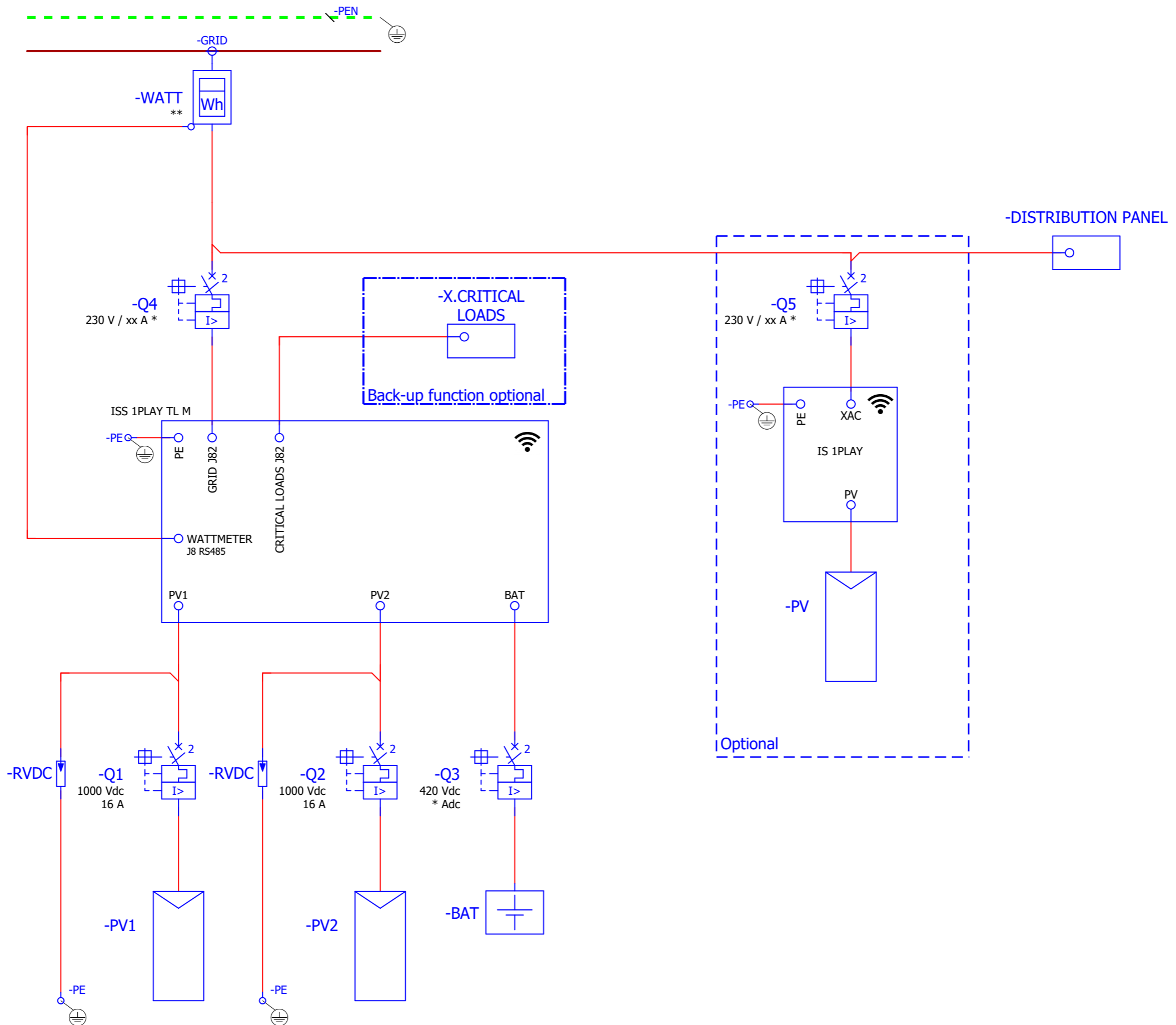

\* The nominal current depends on the power of the installation  
 \*\* Consult the "LIST OF APPROVED POWER METERS FOR ISS 1PLAY TL M"

"The reproduction, distribution and utilization of this document as well as the communication of its contents to others without express authorization is prohibited. Offenders will be held liable for the payment of damages. All rights reserved." ISO 16016

"Sin expresa autorización de Ingeteam, queda terminantemente prohibida la reproducción total o parcial de este documento, así como su uso indebido y/o exhibición o comunicación a terceros. De los infractores se exigirá el correspondiente resarcimiento de daños y perjuicios. Quedan reservados todos los derechos." ISO 16016

=/2

20

Date	27/03/2020					
Designed	B.R.S					
Revised						
Rev	Date	Designed	Revised	Approved	Approved	D.B.R



TECHNICAL GUIDE FOR INSTALLATIONS WITH ISS 1PLAY TL M  
 SELF CONSUMPTION INSTALLATION  
 SINGLE-LINE DIAGRAM

Page	10
Rev	

"The reproduction, distribution and utilization of this document as well as the communication of its contents to others without express authorization is prohibited. Offenders will be held liable for the payment of damages. All rights reserved."  
ISO 16016

"Sin expresa autorización de Ingeteam, queda terminantemente prohibida la reproducción total o parcial de este documento, así como su uso indebido y/o exhibición o comunicación a terceros. De los infractores se exigirá el correspondiente resarcimiento de daños y perjuicios. Quedan reservados todos los derechos."  
ISO 16016

----- Optional

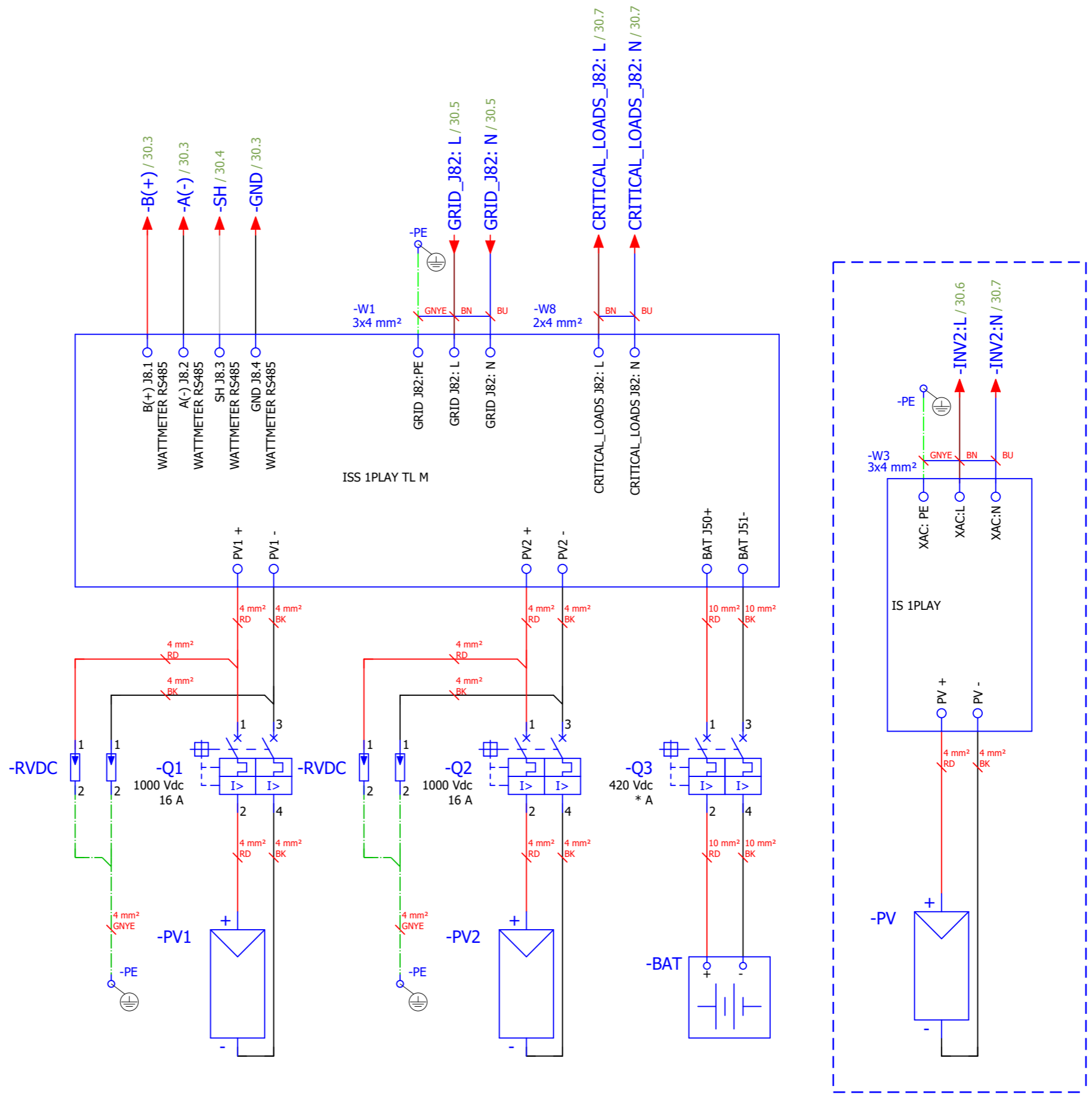

Date	27/03/2020					
Designed	B.R.S					
Revised						
Rev	Date	Designed	Revised	Approved	Approved	D.B.R

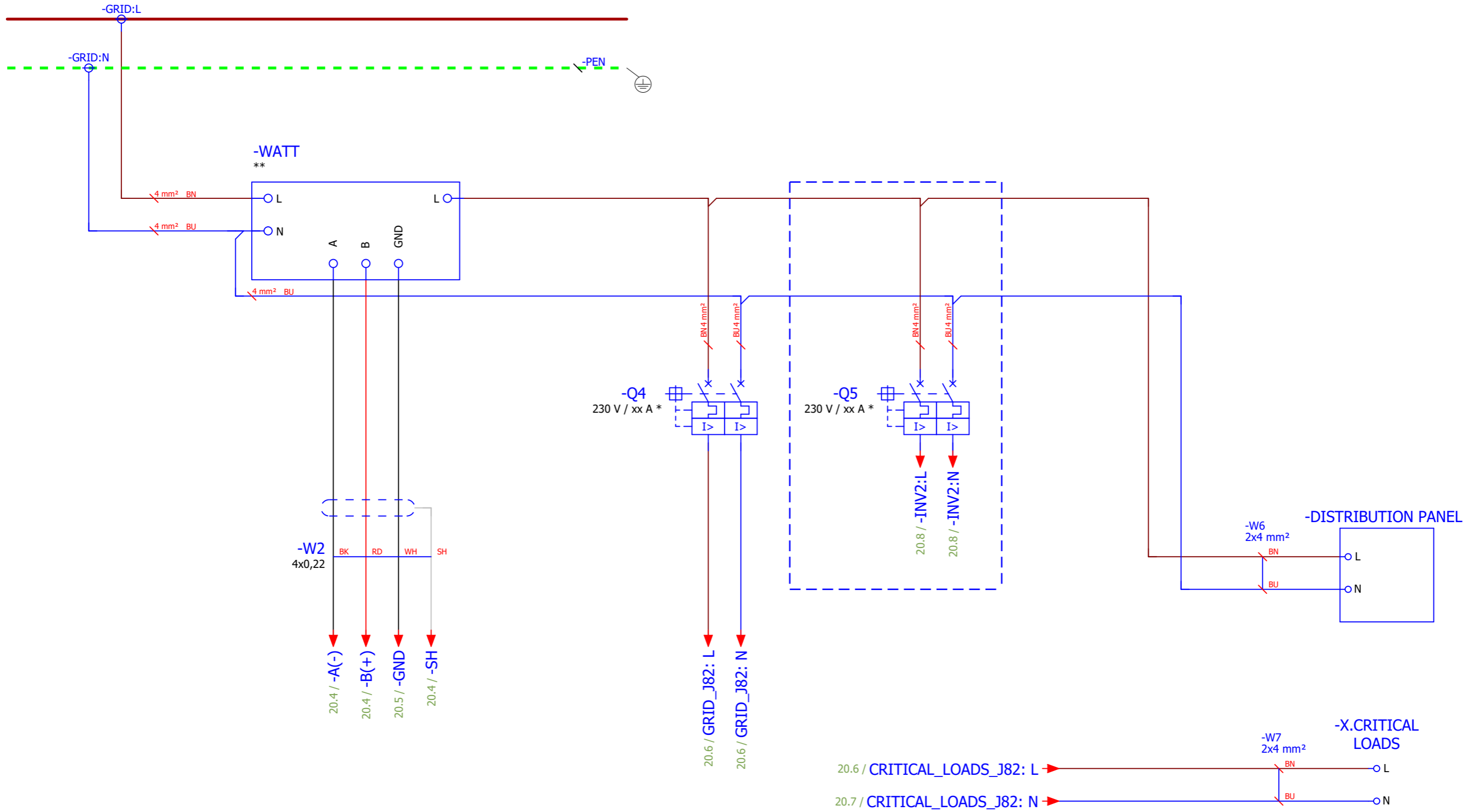

\* The nominal current depends on the power of the installation  
 \*\* Consult the "LIST OF APPROVED POWER METERS FOR ISS 1PLAY TL M"  
 - - Optional

"The reproduction, distribution and utilization of this document as well as the communication of its contents to others without express authorization is prohibited. Offenders will be held liable for the payment of damages. All rights reserved." ISO 16016

"Sin expresa autorización de Ingeteam, queda terminantemente prohibida la reproducción total o parcial de este documento, así como su uso indebido y/o exhibición o comunicación a terceros. De los infractores se exigirá el correspondiente resarcimiento de daños y perjuicios. Quedan reservados todos los derechos." ISO 16016

Date	27/03/2020					
Designed	B.R.S					
Revised						
Rev	Date	Designed	Revised	Approved	Approved	D.B.R