

2334076132_Single Phase Br. Ext-Cable(2.5mm²,1m)

RoHS

CHANGE NO.	CHANGE CONTENTS	REV.	NAME/DATE
①	Update electrical parameters	0.1	LJ 2019-2-28
②	Change the part name	0.2	YFT 2019-7-26
③	Change the label to heat shrinkable tube	0.3	YFT 2020-5-22
④	Update part name; Update electrical parameters	0.4	YFT 2022-6-13
⑤	Update electrical parameters	0.5	YFT 2022-6-30

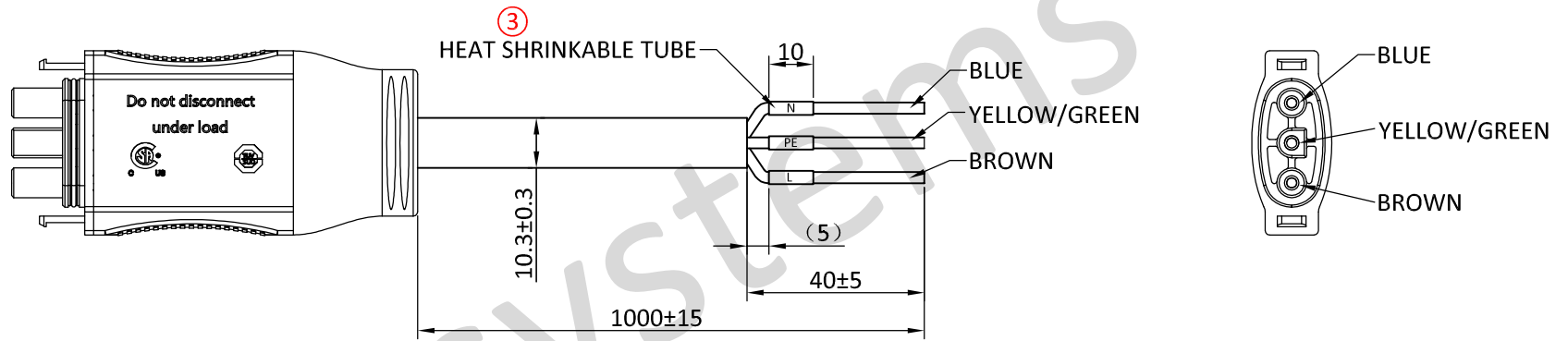

mm ²	COLOR	LABEL
2.5	BROWN	L
	BLUE	N
	YELLOW/GREEN	PE

Notes:

1. Cable: ◀VDE▶ H07RN-F 3G2.5mm² KTL SU01048-6004 SAA101170EA GP-85-PCP
0.6/1.0KV HEAVY DUTY 450/750V WUXI ZHONGHUI WIRE & CABLE CO., LTD
CCC A005618 60245 IEC66 (YCW) 3×2.5mm² 450/750V WUXI SHI ZHONGHUI
XIANLAN YOUXIAN GONGSI

2. Waterproof rating: IP67;

3. Wiring: BROWN-L, BLUE-N, YELLOW/GREEN-PE;

①④⑤

4. Electrical parameters:



Working voltage rating: 600V

Working current rating cable 23A

Resistance voltage: AC 2500V 50mA 1 Minute

Conductor resistance: 7.98Ω/km

5. Use blank cartons for packaging

TOLERANCES UNLESS OTHERWISE SPECIFIED		MATERIAL		 NAME Single Phase Br. ②④ Ext-Cable(2.5mm ² ,1m)
>0-100 ±5	>2500-3500 ±45			
>100-500 ±10	>3500-4500 ±50			
>500-900 ±15	>4500-5500 ±65			
>900-1300 ±25	>5500-6500 ±80			
>1300-1800 ±30	>6500-8000 ±90			
>1800-2500 ±35	>8000-10000 ±100			
DWN.	UNIT mm			
CHK.	SHEET OF	REV. 0.5	DRAWING NO.	