

# **Installation Instruction for Smart Anti-reflux Box**

**Model: SAR-100**

Version: V1.2

## Table of Contents

I	Introduction .....	3
II	Parameters .....	3
III	Product Installation .....	3
	3.1 Tool .....	4
	3.2 Location .....	4
	3.3 Notice .....	5
IV	Anti-reflux System Diagram .....	5
V	Device Installation .....	6
	5.1 Installation .....	7
	5.2 Device Wiring .....	8
VI	Networking Configuration .....	11
	6.1 WiFi Access .....	11
	6.2 Ethernet Access .....	22
VII	Anti-reflux Setup .....	28
	7.1 Anti-reflux Setup .....	28
VIII	Instruction for Indicator Light, Dial Switch and Reset Button .....	34
	8.1 Indicator Light .....	34
	8.2 Dial Switch .....	35
	8.3 Reset Button .....	35
IX	Monitoring .....	36
	9.1 Register .....	36
	9.2 SOLARMAN Smart APP .....	37
	9.3 SOLARMAN Business APP .....	43
X	Contact .....	49

## I Introduction

SOLARMAN anti-reflux box enables the real-time monitoring of grid-tied situation through the integration of three-phase meter, logger and CT, which meets the requirement of real-time adjusting inverter output power at power consumption scenario. It can connect to many inverters and support data transmission via WiFi&Ethernet. It also supports the anti-reflux application of parallel-connected machine for G3 series PV inverter.





## II Parameters

Parameter	
Product Model	SAR-100
Remote Communication	2.4G WiFi+Ethernet
Local Communication	RS 485
No. of Connections	5 or 10
Accessing Method	Three-Phase Four-Wire
Working Voltage	3x230/400V 50/60Hz
Working Current	3x1.5(6)A
IP Grade	IP65
Working Temperature	-25℃~+60℃
Working Humidity	5%-95% (No Condensation)
Installation Method	Wall-Hanging
Size	~400*300*170mm
Weight	~4.1kg

## III Product Installation

### 3.1 Tool

Table 3.1 Preparation Tool

Tool Name	Picture	Usage	Note
Wire stripper		Strip cable insulation	
Cross screwdriver		Use to connect	
Cable		Connect logger with router	Shielded twisted pair
Adjustable Wrench		Use to fix expansion screws	
Percussion Drill		Use to drill holes	
Computer with network port		Use to operate network configuration	
COM Line		RS485Communication	(Shielded twisted pair) Diameter: 3-7mm
Voltage-sampling cable		Use to connect voltage sampling signal	Specification:AWG 12-18, 105°/600V
Double-core cable		Use to connect CT signal	Specification:AWG 16-22, 105°/600V

### 3.2 Location

The installation location must meet the following requirements.

3.2.1 The logger should be installed in doors, avoiding damp and dust environment. Direct sunlight and aggressive vapour should also be avoided.

3.2.2 Environment temperature:  $-25^{\circ}\text{C}\sim+60^{\circ}\text{C}$ .

3.2.3 Max. communication distance for RS485 should be less than 500m.

Away from other wiring routes or pipes in doors, such as gas pipe, water pipe, electric wire and etc.

3.2.4 Away from metal structure to ensure wireless signal strength.

### 3.3 Notice

3.3.1 Power off the device before installation.

3.3.2 Double check the connection before power on the device.

## IV Anti-reflux System Diagram

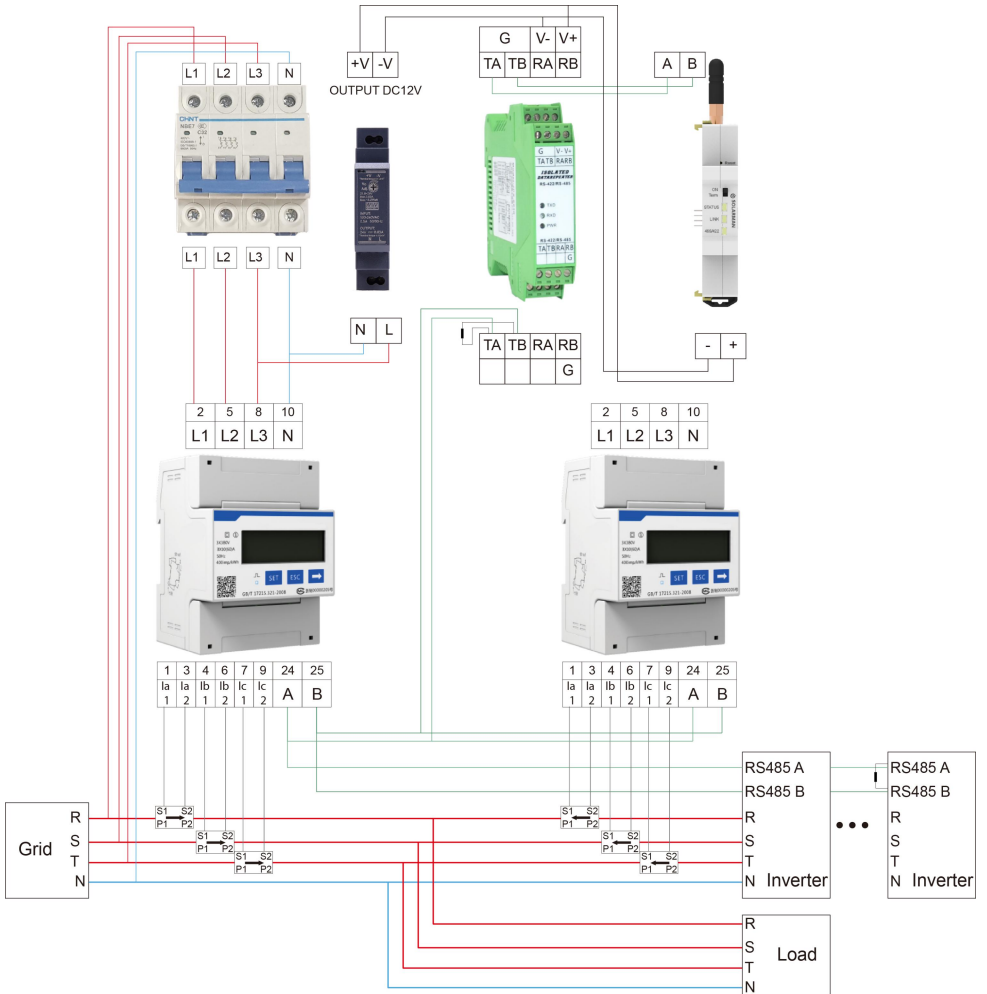

—— 如果RS485链路上存在个别逆变器没通信成功，请将120Ω电阻连在中继器和最后一台逆变器的A和B上

If 485 link communication is not successful for some inverters, please connect a 120Ωresistance with repeater and A&B point of the last inverter.

## V Device Installation

## 5.1 Installation (Please install near the crossroad of grid side and power generation side.)

1. Select a right (firm&flat) place to install the device
2. Determine the drilling hole positions according to hangers (Refer to Fig. 5.1)
3. Fix the device using expansion screws

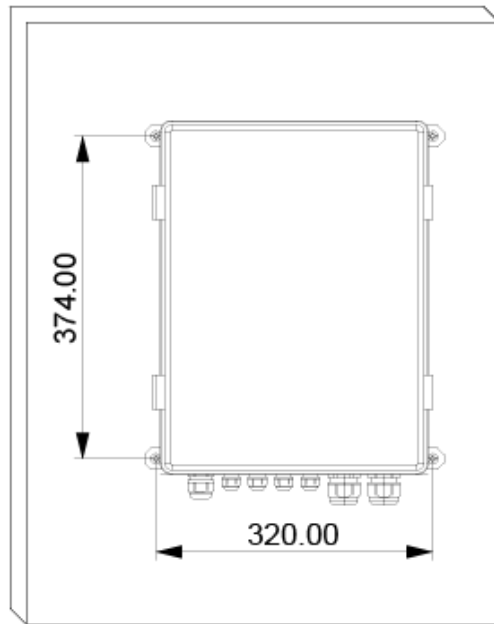

Fig. 5.1 Installation Diagram (Unit: mm)

## 5.2 Device Wiring

### Notice

1. Connect inverter output to the grid. Connect to phase line R ,S, T, N accordingly.
2. Connect voltage-sampling signal line, communication distance should be less than 100m. Connect to phase line R ,S, T, N accordingly.
3. Connect CT, communication distance should be less than<10m. CT direction should be from grid to load and make sure R-phase CT connect to CT1-1/2, S-phase CT connect to CT2-1/2, T-phase CT connect to CT3-1/2.

[Phase sequence of CT should be consistent with the phase sequence of voltage-sampling signal.  $\pm 1/2$  cannot be reversed. (Select current sensor according to the device capacity.)]



4. RS485A-B cannot be reversed.
5. All devices can connect to ground line.

### Inverter address settings

- 1.Meter address: 1
  - 2.For one inverter, inverter address: 2
  - 3.For multiple inverters, inverter address: 2, 3, 4, 5.....
- Tip: Address cannot be the same.
- 4.No need to set anti-reflux function at LCD screen.

Notice: Please make sure local anti-reflux function: OFF.



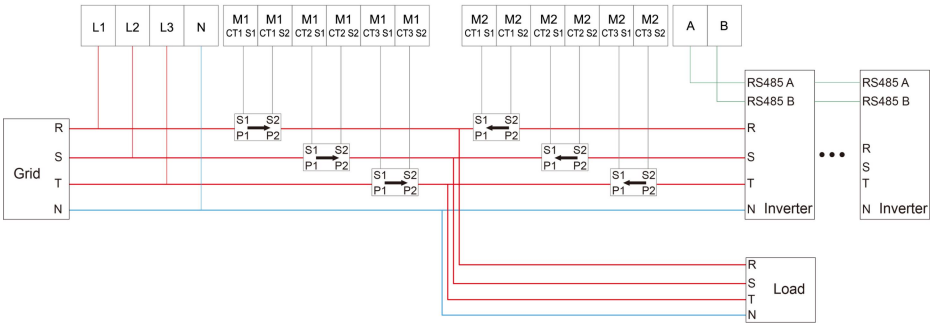
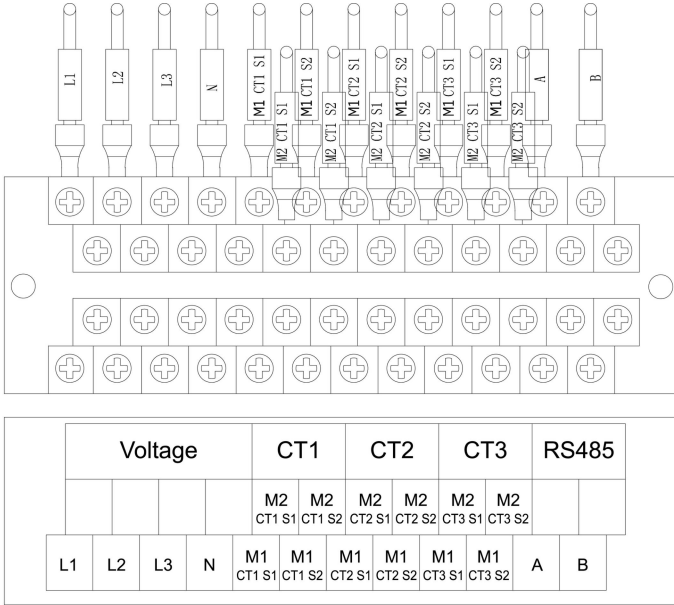

Double check the wiring and power on the device

## 5.3 Change external antenna

### 5.3.1 Unscrew the small antenna of DIN-Rail logger

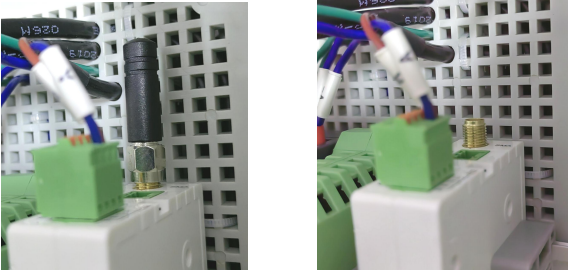

### 5.3.2 Thread the external antenna lead through the waterproof joint, insert the rubber at the bottom of the antenna, and tighten the waterproof cap



### 5.3.3 Screw the external antenna SMA head onto the logger

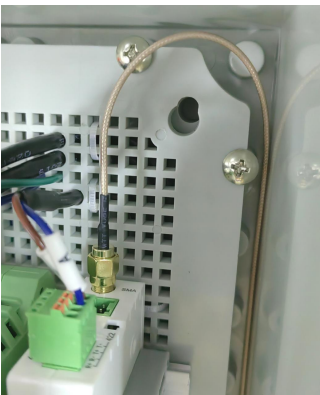

## VI Networking Configuration

If the networking configuration is required, please follow the step and the stick logger along with the inverter does not need to install.

If the anti-reflux box is only used for anti-reflux purpose, users can skip this step directly and install the stick logger accordingly.



**Notice:**

- DIN-Rail logger supports WiFi&Ethernet access. Please select one method to access according to actual situation.**

### 6.1 WiFi Access

**Go to DIN-Rail logger configuration page**

Step 1 Prepare a computer/smart phone that can connect to wireless network

Step 2 Connect to logger AP (Please do Not connect the cable when configuring the logger)

Select and connect AP XXXXXXXXX in the network list (XXXXXXXX means logger SN)



### Step 3 Log in to logger WEB page

Open a browser and enter 10.10.100.254.

Username: admin

Password: admin



#### Notice:

**Supported browser: IE 8+, Chrome 15+, Firefox 10+**

**Sign in to access this site**

Authorization required by http://10.10.100.254  
Your connection to this site is not secure

Username

Password

Step 4 During the first login, the browser will remind you whether to save the password. You can decide according to your usage habit.

Step 5 During the first login, the system will prompt that the AP is not encrypted. Click **OK** to encrypt it, click **Cancel** if not.

The screenshot shows the IGEN web interface. On the left is a navigation menu with options: Status, Wizard, Wireless, Cable, Advanced, Upgrade, Restart, and Reset. The main content area displays system information for a device with serial number 2502324977 and IP address 10.10.100.254. A security warning from 10.10.100.254 is displayed, stating: "Note: AP is not encrypted, which will bring security risks. Do you need to encrypt now?" with "OK" and "Cancel" buttons. A translation popup is also visible, asking "Translate page from Chinese (Simplified)?" with a dropdown set to "English" and "Translate" and "Not now" buttons.

Step 6 If you choose to encrypt AP, you will go to “AP Encryption Modification”, enter your password and click **Save**.

Example: choose WPA2-PSK as encryption mode, AES as encryption algorithm, password: 12345678 (Please remember the password.)

Users can select encryption mode according to actual situation. After AP has been encrypted, it requires to connect AP again.

(If you forget your password or want to cancel the encryption, please long press Reset button for 4s to reset which will go to reconfiguration process. AP password, network information and anti-reflux settings will restore factory settings at this time.)

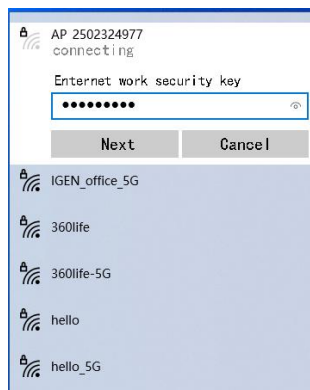
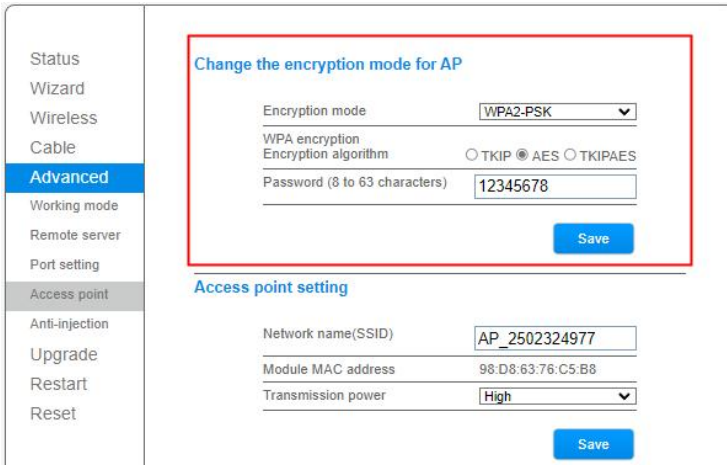

Step 7 Click **Reboot** after saving.

Status	<p><b>Saved successfully!</b></p> <p>Configurations will take effect after restart.</p> <p>After restart, you will need to re-login the configuration interface for other settings, so it is recommended to restart after completing all settings.</p> <p>Please click [Restart] to restart now, or click [Back] to continue setting and restart later with the restart function on left menu.</p> <p><a href="#">Restart</a>   <a href="#">Back</a></p>
Wizard	
Wireless	
Cable	
<b>Advanced</b>	
Working mode	
Remote server	
Port setting	
Access point	
Anti-injection	
Upgrade	
Restart	
Reset	

Status	<p><b>Rebooting successful!</b></p> <p>To re-login the configuration interface, please make sure that your computer or smart phone and our device are in the same network segment, and enter the new IP address of the device to access the interface.</p>
<u>Wizard</u>	
Wireless	
Cable	
<b>Advanced</b>	
Working mode	
Remote server	
Port setting	
Access point	
Anti-injection	
Upgrade	
Restart	
Reset	

After AP encryption has been set, you will be reminded again during network settings.

If the following prompt shows, you can select "AP encryption modification" accordingly.

The screenshot shows the 'Enhance Security' configuration page. On the left is a navigation menu with options: Status, Wizard (highlighted), Wireless, Cable, Advanced, Upgrade, Restart, and Reset. The main content area is titled 'Enhance Security' and contains the following settings:

- Hide AP**:
- Change the encryption mode for AP**:
- Encryption mode**: WPA2-PSK (dropdown menu)
- WPA encryption**: Encryption algorithm:  TKIP  AES  TKIPAES
- Password (8 to 63 characters)**: 12345678
- Change the user name and password for Web server**:

Step 8 Refresh the WEB page and log in again.

Username: admin

Password: admin

The screenshot shows the IGEN web interface with a 'Sign in to access this site' dialog box overlaid. The background shows the same navigation menu as in the previous screenshot, with 'Wizard' highlighted. The dialog box contains the following text and fields:

- Sign in to access this site**
- Authorization required by http://10.10.100.254
- Your connection to this site is not secure
- Username**: [input field]
- Password**: [input field]
- Sign in** (button)
- Cancel** (button)



### Notice

1. Step 6-8 are for AP encryption. If you will not select AP encryption, skip step 6-8, click **Cancel** in step 5 and go to step 9 directly.

Step 9 Go to setup guide page. Click **Start**

Status

**Wizard**

Wireless

Cable

Advanced

Upgrade

Restart

Reset

**Dear user:**

Thank you for choosing our device.  
Next, you can follow the setup wizard to complete the network setting step by step,  
or you can select the left menu for detailed settings.

★Note: Before setting, please make sure that your wireless or cable network is working.

**Start**

1 2 3 4 5 6 7

Step 10 Select **Wireless connection** and click **Next**

Status

**Wireless**

Cable

Advanced

Upgrade

Restart

Reset

**Connection Settings:**

Wireless connection

Cable connection

Wireless: Enabled ▾

**Back** **Next**

1 2 3 4 5 6 7



Step 11 Select router name and click **Next**, refresh the page if no target router listed

### Notice



1. Router name and password do not support ` ` ; , = ' " characters.
2. 5G WiFi is not supported.
3. Router DHCP function: ON.
4. Router can connect to a network.

Status

Wizard

Wireless

Cable

Advanced

Upgrade

Restart

Reset

Please select your current wireless network:

Site Survey

SSID	BSSID	RSSI	Channel
5	5	NONE%	1
<input checked="" type="radio"/> NETWORK	6c:19:8f:c4:6d:58	81%	1
<input type="radio"/>	C	65%	1
<input type="radio"/>	F	65%	1
<input type="radio"/>	L	34%	1
<input type="radio"/>	76	NONE%	1
<input type="radio"/>		86%	5
<input type="radio"/>		100%	6
<input type="radio"/>	00:65:04:07:07:00	39%	7
<input type="radio"/>		100%	8

★Note: When RSSI of the selected WiFi network is lower than 15%, the connection may be unstable, please select other available network or shorten the distance between the device and router.

[Refresh](#)

---

Add wireless network manually:

Network name (SSID)  
(Note: case sensitive)

Encryption method

Encryption algorithm

[Back](#)
[Next](#)

1   2   **3**   4   5   6   7

---

Step 12 Set router password and click **Next**

This screenshot shows the 'Please enter the wireless network password:' screen in the IGEN wizard. On the left is a navigation menu with 'Wizard' selected. The main area contains two password input fields: 'Password (8-64 bytes) (Note: case sensitive)' and 'Re-enter password'. A 'Show Password' checkbox is present. At the bottom, there are 'Back' and 'Next' buttons and a progress indicator with steps 1 through 7, where step 4 is highlighted.

Step 13 If allocating fixed IP address is not required, select **Obtain an IP address automatically: Enable (Recommended)** and click **Next**

This screenshot shows the 'Please fill in the following information:' screen in the IGEN wizard. The left navigation menu remains the same. The main area features a dropdown menu for 'Obtain an IP address automatically' set to 'Enable'. Below are input fields for 'IP address', 'Subnet mask', 'Gateway address', and 'DNS server address', all containing '0.0.0.0'. 'Back' and 'Next' buttons are at the bottom, along with a progress indicator where step 5 is highlighted.

Step 14 If allocating fixed IP address is required, select **Disable**

Enter the target IP address and click **Next**

Status

**Wizard**

Wireless

Cable

Advanced

Upgrade

Restart

Reset

Please fill in the following information:

Obtain an IP address automatically Enable ▾

Enable

Disable

IP address

Subnet mask

Gateway address

DNS server address

Back Next

1   2   3   4   5   6   7

Step 15.1 If you wish to enhance safety, you can choose “Hide AP” or “AP Encryption Modification”.

“AP Encryption Modification” is recommended.

If you already set AP encryption, please refer to previous steps.

### Notice



1 If you select “Hide AP”, AP will be hided automatically. If you wish to open again, please long press Reset button for 4s to reset which will got to reconfiguration process. AP password, network information and anti-reflux settings will restore factory settings at this time.)

The screenshot shows the 'Enhance Security' configuration page. On the left is a navigation menu with options: Status, Wizard (highlighted), Wireless, Cable, Advanced, Upgrade, Restart, and Reset. The main content area is titled 'Enhance Security' and contains the following elements:

- A heading: 'You can enhance your system security by choosing the following methods'
- A checkbox for 'Hide AP' (unchecked).
- A checkbox for 'Change the encryption mode for AP' (checked).
- An 'Encryption mode' dropdown menu set to 'WPA2-PSK'.
- A 'WPA encryption' section with radio buttons for 'TKIP', 'AES' (selected), and 'TKIP/AES'.
- A 'Password (8 to 63 characters)' input field containing '12345678'.
- A checkbox for 'Change the user name and password for Web server' (unchecked).
- 'Back' and 'Next' buttons.
- A progress bar with steps 1 through 7, where step 6 is highlighted.

Step 15.2 If enhancing safety is not required, click **Next**. System will remind you to encrypt AP, click **Cancel**.

This screenshot shows the same 'Enhance Security' configuration page as above, but with a warning dialog box overlaid on top. The dialog box has the title '10.10.100.254 says' and the text: 'Note: AP is not encrypted, which will bring security risks. Do you need to encrypt now?'. It features 'OK' and 'Cancel' buttons. In the background, the 'Change the encryption mode for AP' checkbox is now unchecked, and the 'Next' button is disabled. The progress bar still shows step 6 as the current step.

Step 16 Click **OK** to complete WiFi configuration

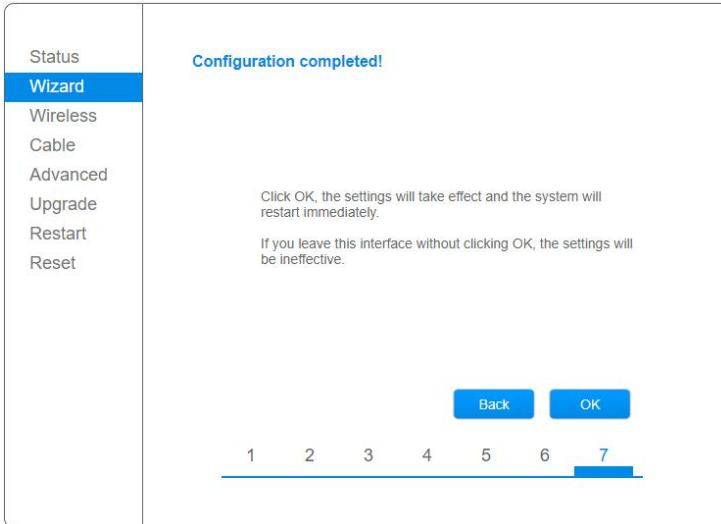

Step 17 Connect AP again according to the notification around 40s. Log in to WEB page and check if the network is successful.

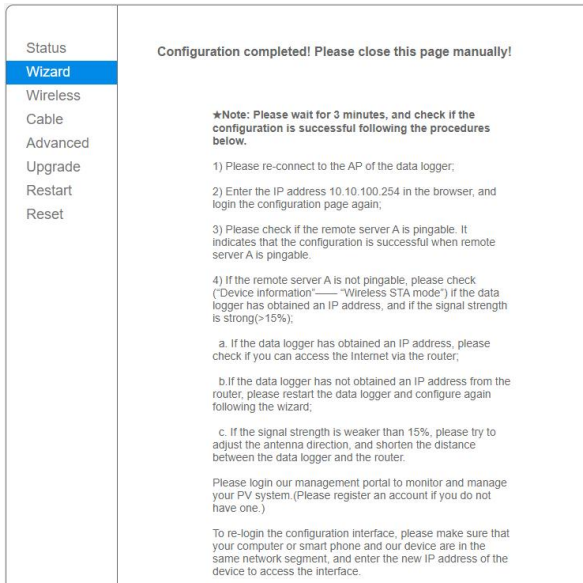

<b>Status</b>	<b>Device information</b>
Wizard	Device serial number 2502324977
Wireless	Firmware version H4.01.51MW.2.01W1.1.8(W512-22030010D)
Cable	Wireless AP mode <b>Enable</b>
Advanced	SSID AP_2502324977
Upgrade	IP address 10.10.100.254
Restart	MAC address 98:D8:63:76:C5:B8
Reset	Wireless STA mode <b>Enable</b>
	Router SSID <b>NETWORK</b>
	Signal quality 86%
	IP address 192.168.64.38
	MAC address 98:D8:63:76:C5:B9
	Cable mode <b>Disable</b>
	IP address
	MAC address
	<b>Connected inverter</b>
	<b>Remote server information</b>
	Remote server A Pingable

## 6.2 Ethernet Access

### Use cable to connect DIN-Rail logger and router



#### Notice

1. Ethernet port of DIN-Rail logger has no lighting function
2. Router DHCP function: ON

Step 1 Select “**Cable connection**”, and set Wireless function: **Enable**. Click **Next**. (Otherwise, you can't connect to AP through mobile phone or computer for web page setting)

Status

**Wizard**

Wireless

Cable

Advanced

Upgrade

Restart

Reset

**Connection Settings:**

Wireless connection

Cable connection

Wireless **Enabled** ▾

Back Next

1 2 3 4 5 6 7

Step 2 If allocating fixed IP address is not required, select **Obtain an IP address automatically: Enable (Recommended)** and click **Next**

Status

**Wizard**

Wireless

Cable

Advanced

Upgrade

Restart

Reset

**Please fill in the following information:**

Obtain an IP address automatically **Enable** ▾

IP address 0.0.0.0

Subnet mask 0.0.0.0

Gateway address 0.0.0.0

DNS server address

Back Next

1 2 3 4 5 6 7

Step 3 If allocating fixed IP address is required, select **Disable**

Enter the target IP address and click **Next**

Status

**Wizard**

Wireless

Cable

Advanced

Upgrade

Restart

Reset

Please fill in the following information:

Obtain an IP address automatically

IP address

Subnet mask

Gateway address

DNS server address

1 2 3 4 **5** 6 7

Step 4 If you wish to enhance safety, you can choose “Hide AP” or “AP Encryption Modification”.

“AP Encryption Modification” is recommended.

If you already set AP encryption, please refer to previous steps.



**Notice**

1 If you select “Hide AP”, AP will be hided automatically. If you wish to open again, please long press Reset button for 4s to reset which will got to reconfiguration process. AP password, network information and anti-reflux settings will restore factory settings at this time.)



Status

**Wizard**

Wireless

Cable

Advanced

Upgrade

Restart

Reset

### Enhance Security

You can enhance your system security by choosing the following methods

**Hide AP**

**Change the encryption mode for AP**

Encryption mode

WPA encryption

Encryption algorithm  TKIP  AES  TKIP/AES

Password (6 to 63 characters)

**Change the user name and password for Web server**

1 2 3 4 5 **6** 7

Step 5 If enhancing safety is not required, click **Next**. System will remind you to encrypt AP, click **Cancel**.

**10.10.100.254 says**

Note: AP is not encrypted, which will bring security risks. Do you need to encrypt now?

Status

**Wizard**

Wireless

Cable

Advanced

Upgrade

Restart

Reset

### Enhance Security

You can enhance your system security by choosing the following methods

**Hide AP**

**Change the encryption mode for AP**

**Change the user name and password for Web server**

1 2 3 4 5 **6** 7

Step 6 Click **OK** to complete Ethernet configuration.

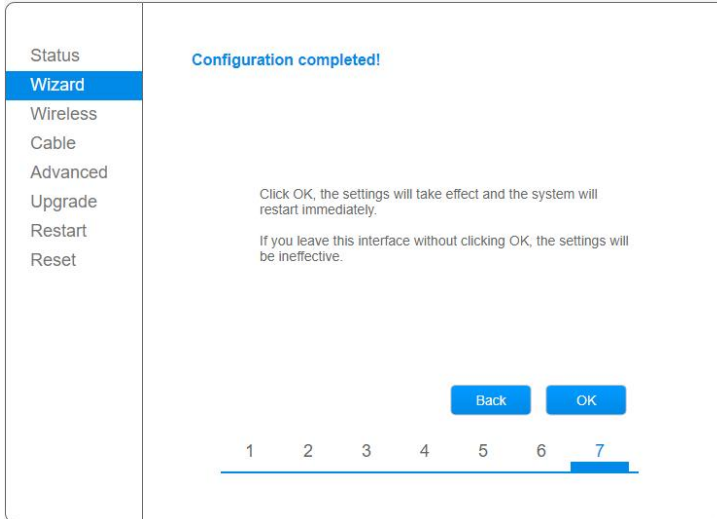

Step 7 Connect AP again according to the notification. Log in to WEB page and check if the network is successful.

If you need to enter the web page through IP address via LAN, please remember the actual IP address in "Wireless Mode".

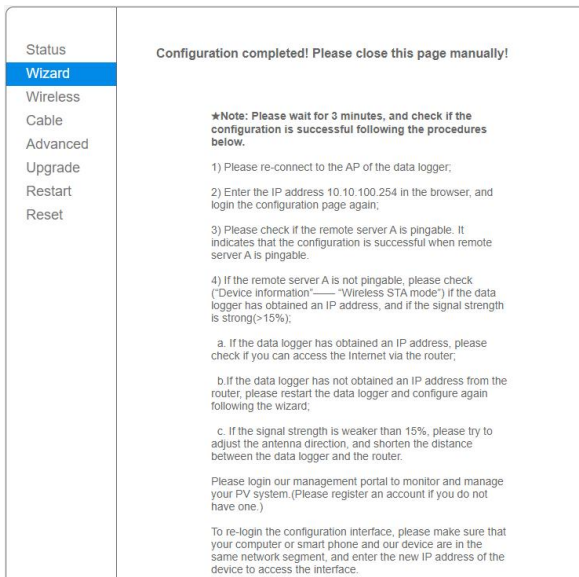

<b>Status</b>	<p>▲ <b>Device information</b></p> <table border="1"> <tr> <td>Device serial number</td> <td>2502324977</td> </tr> <tr> <td>Firmware version</td> <td>H4.01.51MW.2.01W1.1.8(W512-22030010D)</td> </tr> <tr> <td>Wireless AP mode</td> <td style="text-align: right;"><b>Enable</b></td> </tr> <tr> <td>    SSID</td> <td>AP_2502324977</td> </tr> <tr> <td>    IP address</td> <td>10.10.100.254</td> </tr> <tr> <td>    MAC address</td> <td>98:D8:63:76:C5:BB</td> </tr> <tr> <td>Wireless STA mode</td> <td style="text-align: right;"><b>Disable</b></td> </tr> <tr> <td>    Router SSID</td> <td></td> </tr> <tr> <td>    Signal quality</td> <td></td> </tr> <tr> <td>    IP address</td> <td></td> </tr> <tr> <td>    MAC address</td> <td></td> </tr> <tr> <td>Cable mode</td> <td style="text-align: right;"><b>Enable</b></td> </tr> <tr> <td>    IP address</td> <td>192.168.60.69</td> </tr> <tr> <td>    MAC address</td> <td>98:D8:63:76:C5:BB</td> </tr> </table> <p>▼ <b>Connected Inverter</b></p> <table border="1"> <tr> <td>▲ <b>Remote server information</b></td> <td></td> </tr> <tr> <td>Remote server A</td> <td>Pingable</td> </tr> </table>	Device serial number	2502324977	Firmware version	H4.01.51MW.2.01W1.1.8(W512-22030010D)	Wireless AP mode	<b>Enable</b>	SSID	AP_2502324977	IP address	10.10.100.254	MAC address	98:D8:63:76:C5:BB	Wireless STA mode	<b>Disable</b>	Router SSID		Signal quality		IP address		MAC address		Cable mode	<b>Enable</b>	IP address	192.168.60.69	MAC address	98:D8:63:76:C5:BB	▲ <b>Remote server information</b>		Remote server A	Pingable
Device serial number	2502324977																																
Firmware version	H4.01.51MW.2.01W1.1.8(W512-22030010D)																																
Wireless AP mode	<b>Enable</b>																																
SSID	AP_2502324977																																
IP address	10.10.100.254																																
MAC address	98:D8:63:76:C5:BB																																
Wireless STA mode	<b>Disable</b>																																
Router SSID																																	
Signal quality																																	
IP address																																	
MAC address																																	
Cable mode	<b>Enable</b>																																
IP address	192.168.60.69																																
MAC address	98:D8:63:76:C5:BB																																
▲ <b>Remote server information</b>																																	
Remote server A	Pingable																																
Wizard																																	
Wireless																																	
Cable																																	
Advanced																																	
Upgrade																																	
Restart																																	
Reset																																	

After the network setting is completed, you can enter the web page through two methods to set up anti-reflux.

Method 1(Recommended): If AP is visible, connect AP via computer, mobile and other devices.

Open a browser and enter

10.10.100.254 to go.

Method 2: If AP is hided, AP cannot be connected via computer, mobile and other devices. You need to keep the computer or mobile in the same LAN with the logger, and enter the assigned IP address by the logger in the browser to enter the web page.

## VII Anti-reflux Setup

This step is required no matter what the network situation is.

### 7.1 Anti-reflux setup

Step 1 Click **Advanced - Anti-reflux**



**Notice**

**Default: Anti-reflux Mode**

- Status
- Wizard
- Wireless
- Cable
- Advanced
- Working mode
- Remote server
- Port setting
- Access point
- Anti-injection
- Upgrade
- Restart
- Reset

### Anti-Injection Setting

Anti-Injection Work Mode Setting Anti-Injection Mode ▾

---

Save

Anti-Injection Power Setting(w) 0

---

Save

Number of inverters 1

---

Save

CT Ratio Setting 1

---

Save

Meter Address-Meter1	1
Meter Address-Meter2	100

## Step 2 Select **Anti-reflux Working Mode**

Set anti-reflux power: 0 W (Default).

If it is allowed to purchase electricity at a fixed power, please set according to purchasing power. (e.g. If the purchasing power is 1500W, please enter 1500.)

### Anti-Injection Setting

Anti-Injection Work Mode Setting

Save

Anti-Injection Power Setting(w)

Save

If you wish to sell the electricity, please select “Selling Mode”and enter selling power. (e.g. If the selling power is 100W, please enter 100.)

### Anti-Injection Setting

Anti-Injection Work Mode Setting

Save

Selling power setting(w)

Save

Step 3 Set inverter number (Please set according to actual inverter number.)

Number of inverters

Save

Step 4 Set CT ratio of meter on grid side (Meter1)

CT Ratio Setting

Save

### CT Ratio Setup

If you use 200/5A CT, please enter 40 and click “Save” .

After the setup, logger will reboot and send the ratio modification automatically.

Step 5 Click **Save - Reboot**

The screenshot shows a configuration interface with a left sidebar menu and a main content area. The sidebar menu includes: Status, Wizard, Wireless, Cable, **Advanced** (highlighted), Working mode, Remote server, Port setting, Access point, Anti-injection, Upgrade, Restart, and Reset. The main content area displays the message "Saved successfully!" and provides instructions: "Configurations will take effect after restart. After restart, you will need to re-login the configuration interface for other settings, so it is recommended to restart after completing all settings. Please click [Restart] to restart now, or click [Back] to continue setting and restart later with the restart function on left menu." At the bottom right of the main content area, there are two buttons: "Restart" and "Back".

Step 6 Set CT ratio and systematical error of meter on generation side (Meter2)

Find a computer or a mobile phone to connect logger AP (XXXXXXXX presents SN).

(E.g. AP\_2502324799)



Go to a browser and enter "10.10.100.254/fnI\_hide.html", then go to anti-reflux hidden setup page.

**Anti-Injection Setting**

Inverter execution time(x10 ms)

Current transformation ratio of generating power meter

Load Balance Settings

Data upload cloud settings

Systematical Error Power Percentage(%)

1. Set “Current ratio of generation power meter”

Set CT ratio of meter on generation side (Meter2), please set according to actual situation.

Current transformation ratio of generating power meter

2. Set “Systematical error”

Default: 1%.

If you wish to modify, please check CT accuracy (Calculation of systematical error: meter error+CT error. E.g. CT error: 0.5%, meter error: 0.5%, systematical error will be 1%.)

Systematical Error Power Percentage(%)





**Notice**

It is recommended to use CT with its error $<0.5\%$ .

## VIII Instruction for Indicator Light, Dial Switch and



### Reset Button

#### 8.1 Indicator Light



After DIN-Rail logger (WiFi/ETH) connected to the device and networking is normal, check the status of STATUS light, LINK light, 485/422 light.

(There is only one light for each STATUS light, LINK light, 485/422 light.)

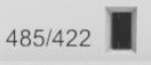
##### Logger light

Light	Implication	Instruction
	Logger working status	<ol style="list-style-type: none"> <li>1. OFF: DIN-Rail logger (WiFi/ETH) works abnormally.</li> <li>2. ON: DIN-Rail logger (WiFi/ETH) works normally.</li> <li>3. ON after 5s: DIN-Rail logger (WiFi/ETH) starts/restarts.</li> </ol>
	Communication status with logger and router	<ol style="list-style-type: none"> <li>1. Flashing: Network configuration is not conducted after first power on or reset.</li> <li>2. Configure to WiFi and connect to router: Light: ON; If not, Light: OFF</li> <li>3. Configure to Ethernet and connect to router: Light: Flash; If not, Light: Flash</li> </ol>
	Communication status with logger and inverter	<ol style="list-style-type: none"> <li>1. ON/Fast Flash: DIN-Rail logger (WiFi/ETH) connected to inverter and communicate normally.</li> <li>2.OFF: DIN-Rail logger (WiFi/ETH) not connected to inverter and communicate abnormally.</li> </ol>

Repeater light

Light	Implication	Instruction
	RS485 IN	<ol style="list-style-type: none"> <li>1. OFF: No data transmission</li> <li>2. Flash: Data transmitting</li> <li>3. ON: Abnormal</li> </ol>
	RS485 OUT	<ol style="list-style-type: none"> <li>1. OFF: No data transmission</li> <li>2. Flash: Data transmitting</li> <li>3. ON: Abnormal</li> </ol>
	Power	<ol style="list-style-type: none"> <li>1. ON: Normal power-on</li> <li>2. OFF: Fail to power on</li> </ol>

8.2 Dial Switch

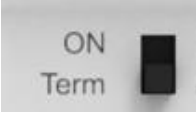
Light	Implication	Instruction
	RS485 terminal 120Ω matching resistance switch	<p>Default:Term</p> <p>ON:A problem with 485 link when there are various inverter on site (Turn on one dial switch either for logger or inverter;</p> <p>If a repeater is connected, there is no need to turn on this switch)</p>

8.3 Reset Button

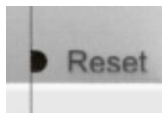
Light	Implication	Instruction
	Reset button	Long press for 4s to reset the logger and restore factory settings.

## IX SOLARMAN Monitoring

If the anti-reflux box is only used for anti-reflux purpose, networking is not required, users can skip this step directly.

### 9.1 Register

If you have a household PV plant, it is recommended to use SOLARMAN Smart.

Scan the QR code below to download or go to Android/App Store searching for SOLARMAN Smart.

For web: <https://home.solarmanpv.com>



SOLARMAN Smart

If you are a distributor, O&M provider, manufacturer in PV field, it is recommended to use SOLARMAN Business.

Scan the QR code below to download or go to Android/App Store searching for SOLARMAN Business.

For web: <https://pro.solarmanpv.com>



SOLARMAN Business

## 9.2 SOLARMAN Smart APP

### Step 1 Registration

Go to SOLARMAN Smart APP and click “Register a new account” and select “E-mail” or “Phone Number” to register.

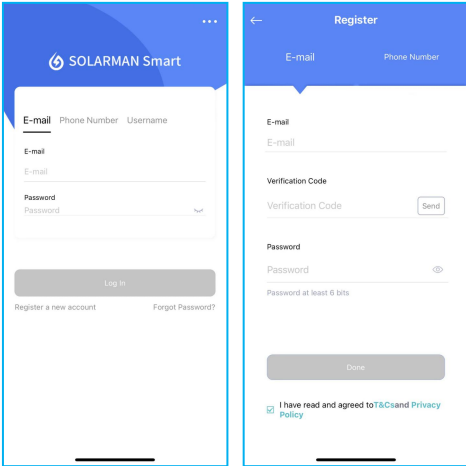

### Step 2 Create a plant

Click “Add Now”.

Choose “Yes” to select “Create Plant By Myself”.

Choose “No” to select “Create Now”.

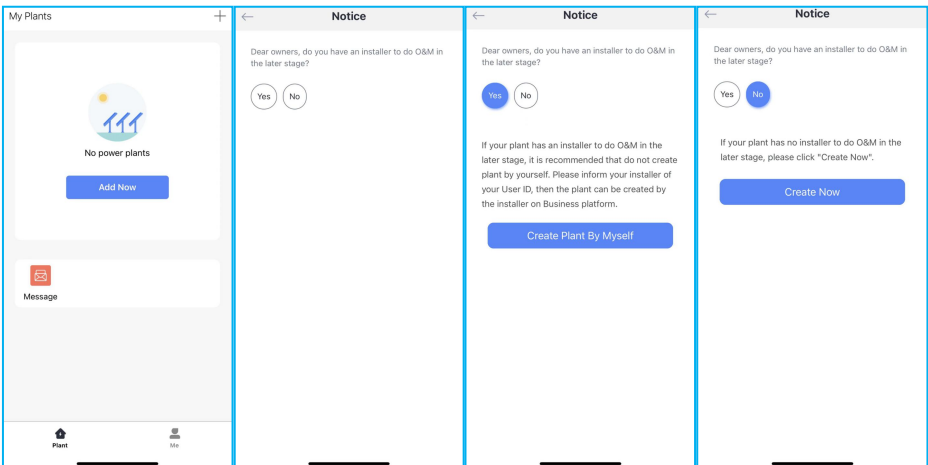

## Step 2.1

Users can select plant location automatically or enter plant location manually, then click “Next”.  
Please select “system type” as “Self-consumption”.

Users need to enter plant information here, click “Done” to complete.

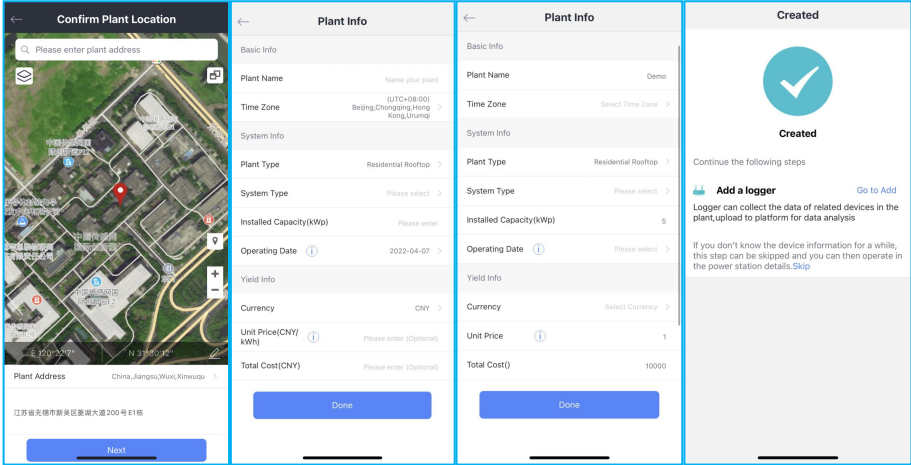

## Step 3 Add a logger

Click “Go to Add”, enter SN manually or scan bar code, then click “Add”.

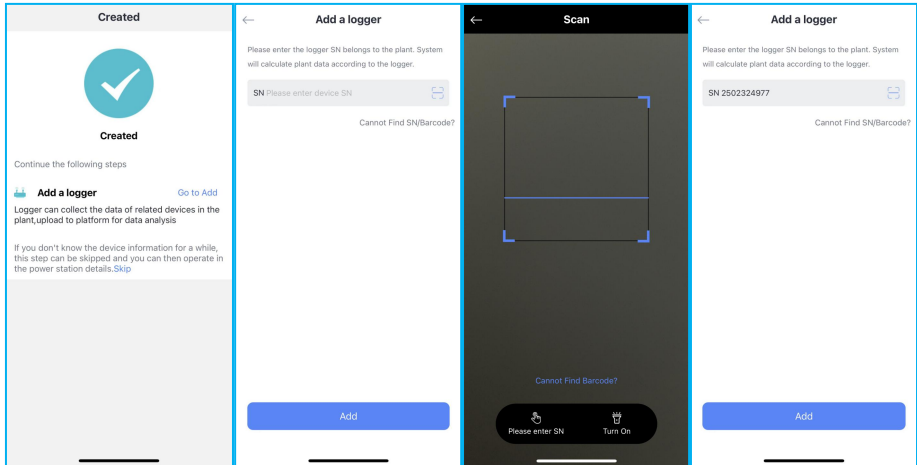

## Step 3.1

Click “Skip” to return homepage and click plant name to visit a plant.

User can click “...” in the upper right corner and click “Add a logger”.

(Please follow step 3)

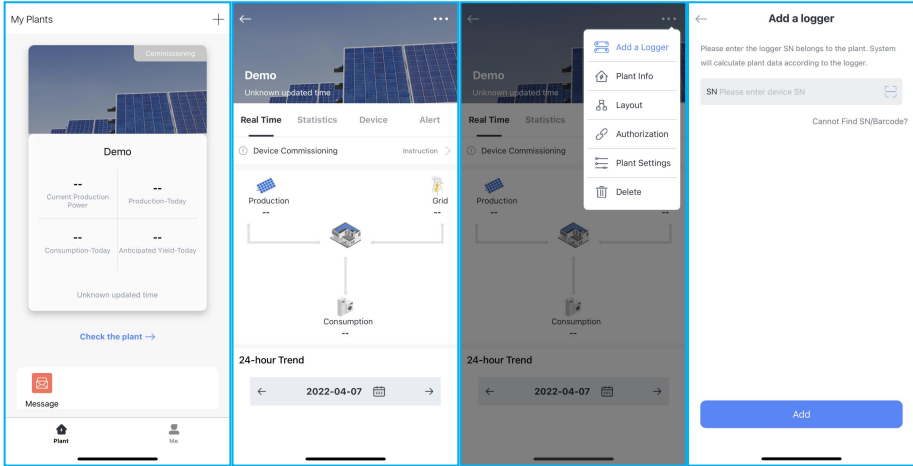

## Step 4 Select associated device

After the logger is added, system will go to “Select associated device”, if you will not change associated method, click “Done”. If you are going to change associated method, click “Manual selection”.

(Network configuration has been done at step 6)

Click “Later” to return to homepage.



### Notice

Logger SN will be displayed in the device list after 10 mins.

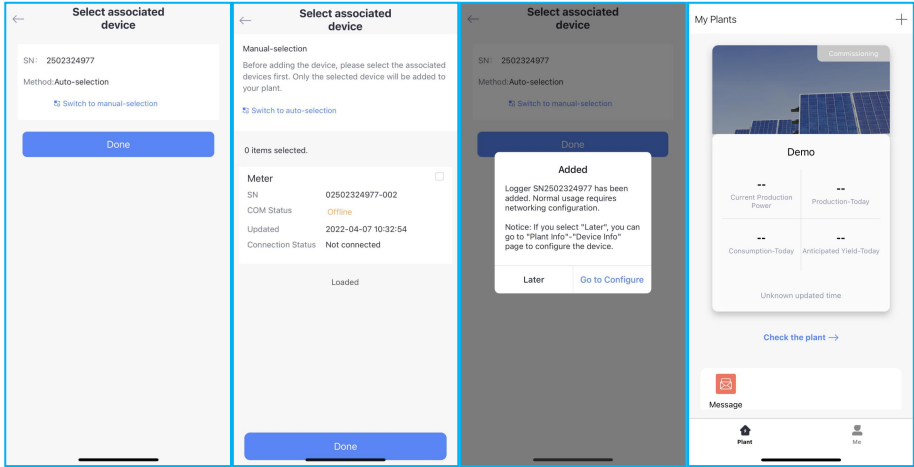

## Step 5 Meter configuration

Click plant name to visit a plant. (If you are in plant details page, you can click “Device” directly)  
 Click “Device”-“Meter”-“Meter configuration”, go to select “Three-phase System”-“Grid”, click a blue arrow in CT direction and change to “Energy Purchase”.

Current ratio can set according to CT specification. (e.g. If you choose 200/5A CT, set current ratio as 200/5)

Click “Done” to return to “Device” page.

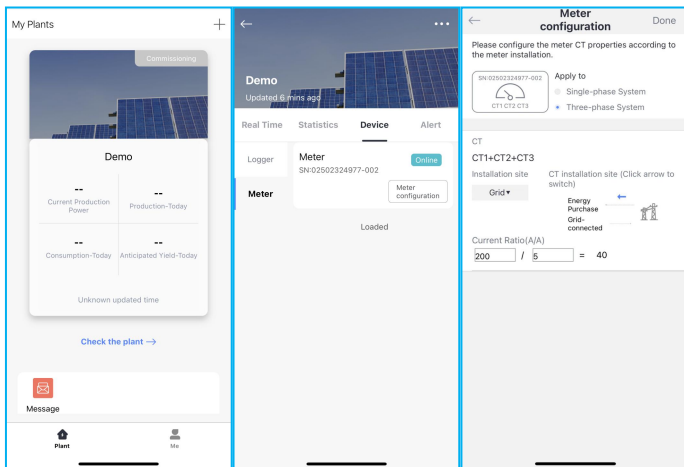

## Step 6 Plant Settings



Set power calculation method, data sourcing and non-operating hours

## 6.1 Power calculation method

Click “...” in the upper right corner and go to “Plant Settings”. Click “Power calculation method”, set “Based on device data” for total energy, set “Based on calculation data” for total consumption, set “Based on device data” for total grid-tie energy, set “Based on device data” for total energy purchased and click “Save”.

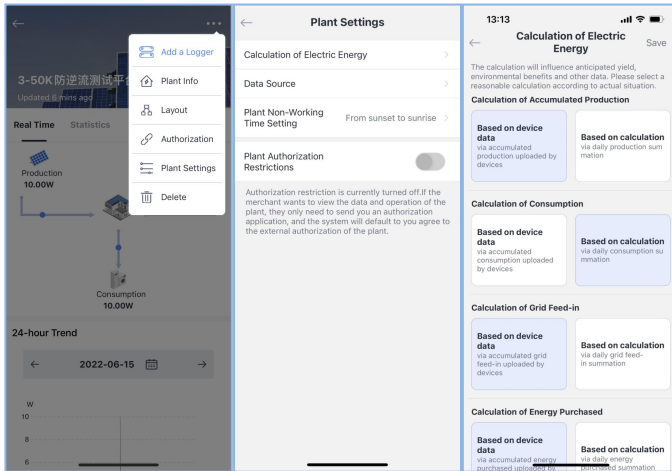

## 6.2 Data sourcing

Click “Data sourcing”-“Switch to manual selection”. Select “Grid-tie” for grid side, select “Inverter data summation” for generation, select “Meter data summation” for grid and select “Calculation method” for consumption and click “Save”.

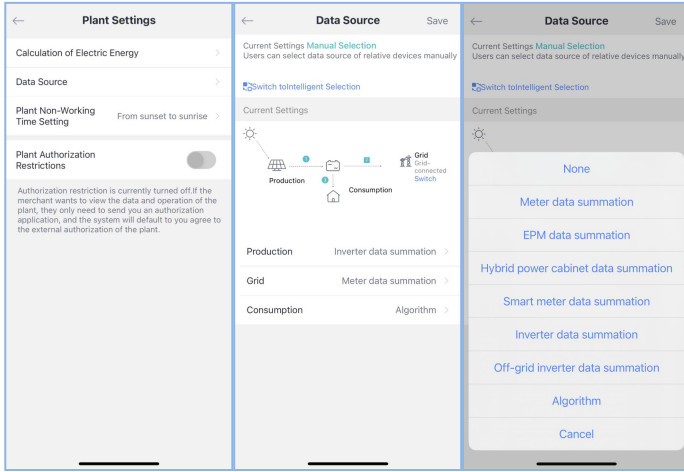

### 6.3 Non-operating hours

Click Non-operating hours settings and enable it.

Effective time: **From sunrise to sunset**.

Click **“Save”**.

(Uses can set the time according to actual situation.)

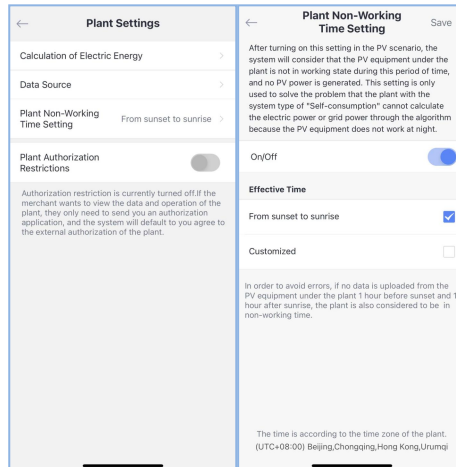

### 6.4 Back to plant details to check data.

### 9.3 SOLARMAN Business APP

Step 1 Registration Go to SOLARMAN Business APP and click “Register” - “Switch to E-mail registration”. Tick “T&Cs” and click “Next”. Select “Business Type”, enter “Business Name”, select “Business Area”, select “Type” and click “Next”.

If you already have an account, click “Click here” to return to login page.

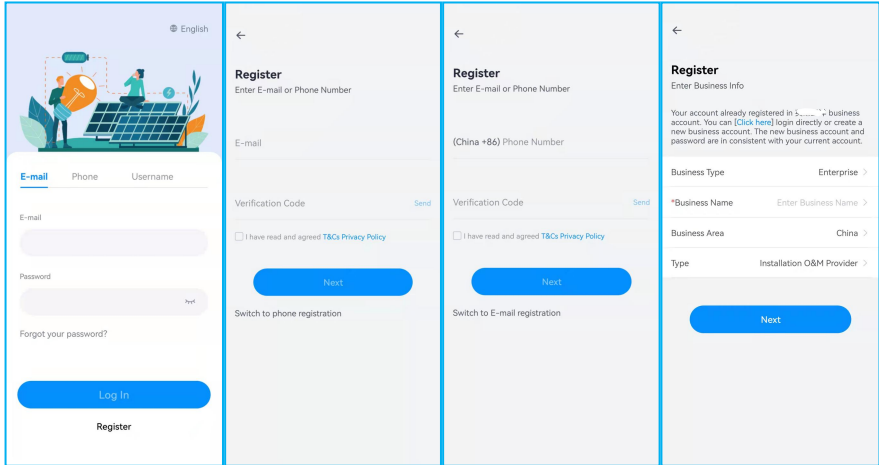

The following page will display and click “Finished and Log In” to return to login page. Enter information and click “Log In”.

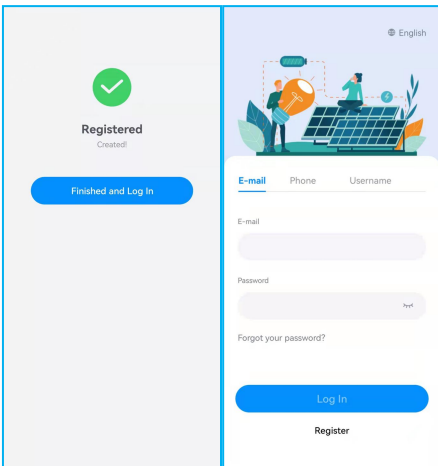

## Step 2 Create a plant

Click “+” in the upper right corner, select “Create a Plant” and enter plant information, select system type as “PV+Grid+Consumption”, then click “Save”.

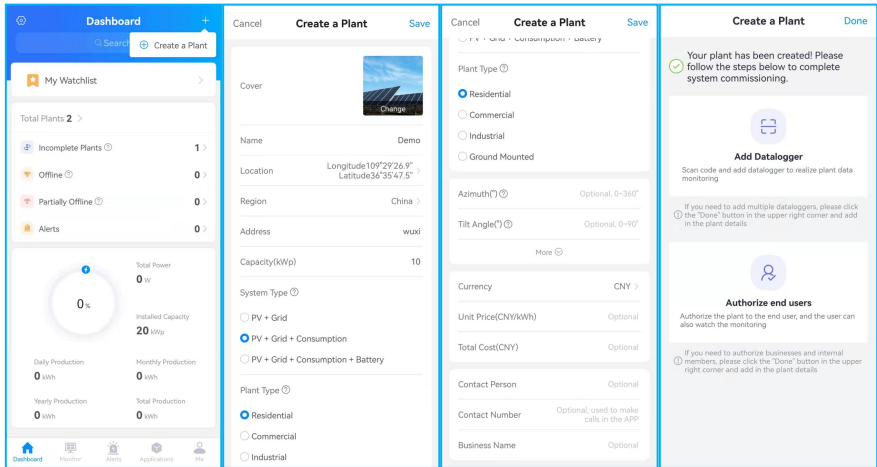

## Step 3 Add a logger

Click “Add Data logger”, enter SN manually or scan bar code, then click “Done”.

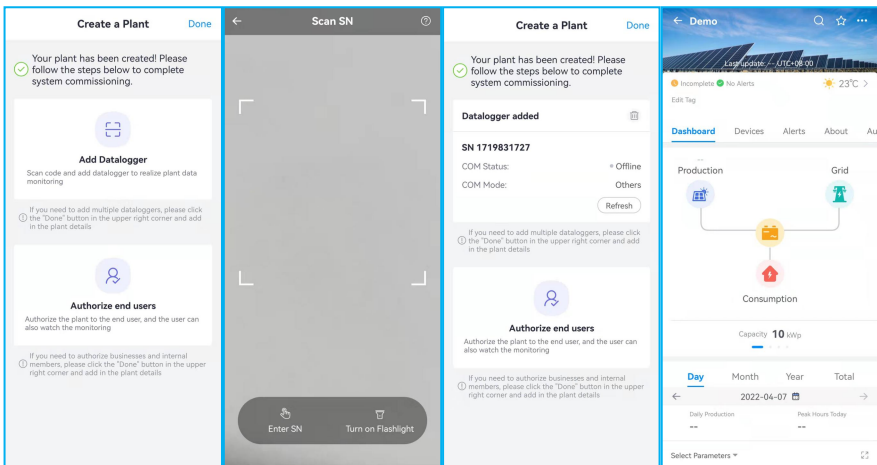

## Step 3.1

If not, click “Done” to return to “Dashboard”.

Click “...” in the upper right corner in “Dashboard” page, click “Add Data logger”, enter SN manually or scan bar code, then click “Confirm”.

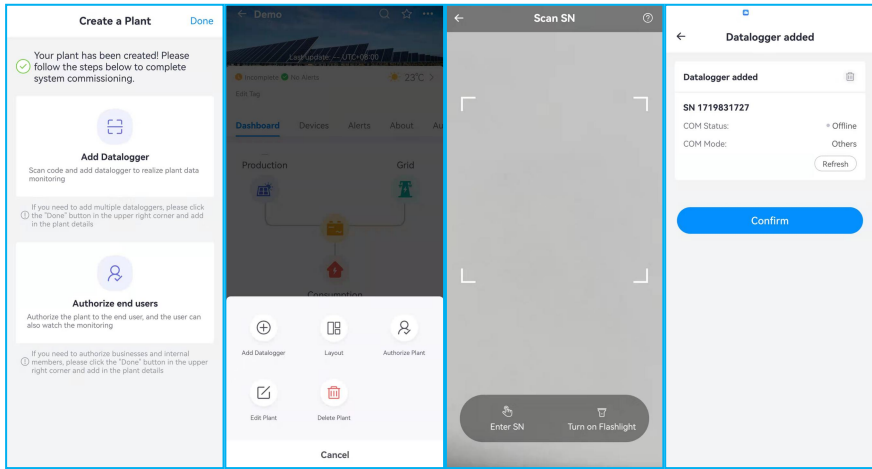

### Notice

Logger SN will be displayed in the device list after 10 mins.

### Step 4 Meter configuration

Click “Devices”, choose target meter and click “Meter configuration”, go to select “Grid”, click a blue arrow in CT direction and change to “Energy Purchase”.

Current ratio can set according to CT specification. (e.g. If you choose 200/5A CT, set current ratio as 200/5)

Click “Save” to return to “Devices” page.

(System will use three-phase/single-phase system in default.)

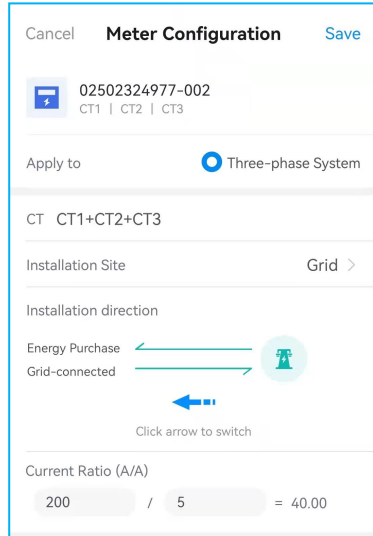
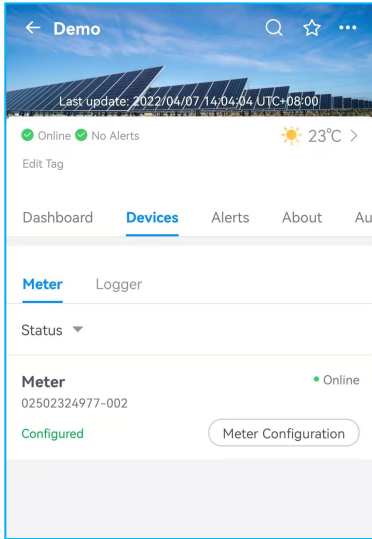

Step 5 Plant Settings (SOLARMAN Business APP does not support the settings, please go to SOLARMAN Business Web to set.)

Set power calculation method, data sourcing and non-operating hours

### 5.1 Data sourcing

Click “More” in the upper-right corner, go to “Plant Settings” and click “Data sourcing”.

Select “**Manual Modification**” and the arrow at Place 4 will point to grid.

Select “**Inverter data summation**” for generation, select “**Meter data summation**” for grid and select “**Calculation method**” for consumption and click “**Save**”.

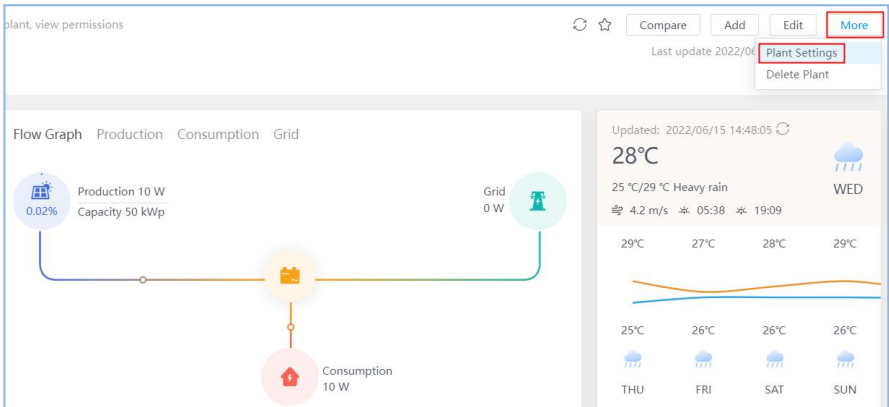

### Plant Settings

- Data Source [Settings](#)
- Calculation of accumulated electricity [Settings](#)
- Offset [Settings](#)
- Planned Production [Settings](#)
- Plant Non-Working Time Setting Not Enabled [Settings](#)
- Plant authorization restrictions
  - Authorization restriction is turned off now.
  - Manufacturers and distributors can directly view the data and operation of the plant.

### Plant Settings / Data Source

Here is current flow simulation diagram for PV + Grid + Consumption plant. Please set data source.

The diagram shows a flow from 'Production' (1) to 'Production (Theoretical)' (2), then to 'Consumption' (5), and finally to 'Grid' (4). A 'Click to Switch' button is located between the 'Production' and 'Grid' nodes.

- 1 Data Type: Irradiation(Irradiance, Irradiation)  
Data Source: None
- 2 Data Type: Theoretical Energy (Include Theoretical Production)  
Data Source: None
- 3 Data Type: Production (Production Power/Ceasche)  
Data Source: Inverter data summation
- 4 Data Type: Grid (Grid Power/Grid Status/Grid Feed-in/Energy Purchased)  
Data Source: Meter data summation
- 5 Data Type: Consumption(Include Consumption Power and Consumption)  
Data Source: Algorithm

Buttons: Cancel, Save

## 5.2 Power calculation method

Click "Power calculation method"

Select "Accumulated production summation uploaded by devices" for calculation of accumulated production.

Select "Daily consumption summation" for calculation of accumulated consumption.

Select "Energy purchased summation uploaded by devices" for calculation of energy purchased.

Select "Grid feed-in summation uploaded by devices" for calculation of grid feed-in.

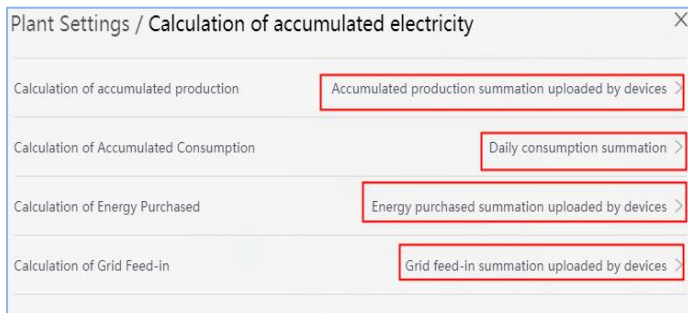
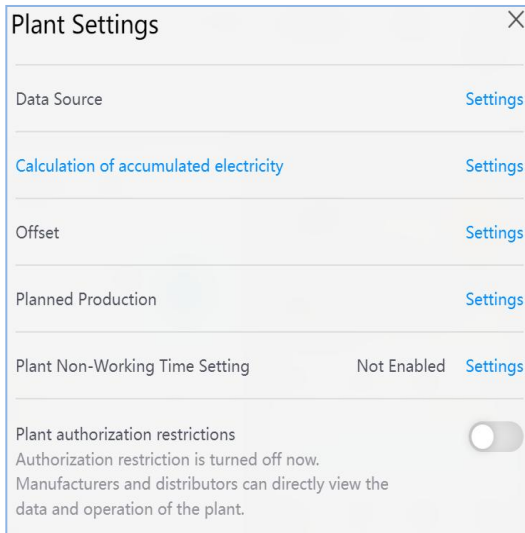

### 5.3 Non-operating hours

Click Non-operating hours settings and enable it.

Effective time: **From sunrise to sunset.**

Click **“Save”**.

(Uses can set the time according to actual situation.)



**Plant Settings** ✕

---

Data Source Settings

---

Calculation of accumulated electricity Settings

---

Offset Settings

---

Planned Production Settings

---

Plant Non-Working Time Setting Not Enabled Settings

---

Plant authorization restrictions   
Authorization restriction is turned off now. Manufacturers and distributors can directly view the data and operation of the plant.

**Plant Settings / Plant Non-Working Time Setting** ✕

---

The plant non-working time setting is only used to solve the problem that the plant with the grid type of "self-consumption" cannot calculate the electric power or grid power through algorithms because the inverter does not work at night.

---

On

---

Effective Time

From Sunset to Sunrise

Customized Time

---

If there is no production power within 1 hour before sunset and 1 hour after sunrise, the system will also automatically make the production power to zero.

5.4 Back to plant details to check data.

## X Contact

IGEN Tech Co., Ltd.

Add: Block F4, China IoT International Innovation Park, No. 200, Linghu Avenue,

Wuxi, Jiangsu, P. R. China

Tel: +86-400-181-0512

Email: [info@solarmanpv.com](mailto:info@solarmanpv.com)

Website: [www.solarmanpv.com](http://www.solarmanpv.com)